



ZÁRSZERKEZETEK ZÁRHÁZAK ÉS ZÁRBETÉTEK

Zárbetét típusok



Ajtókibontások

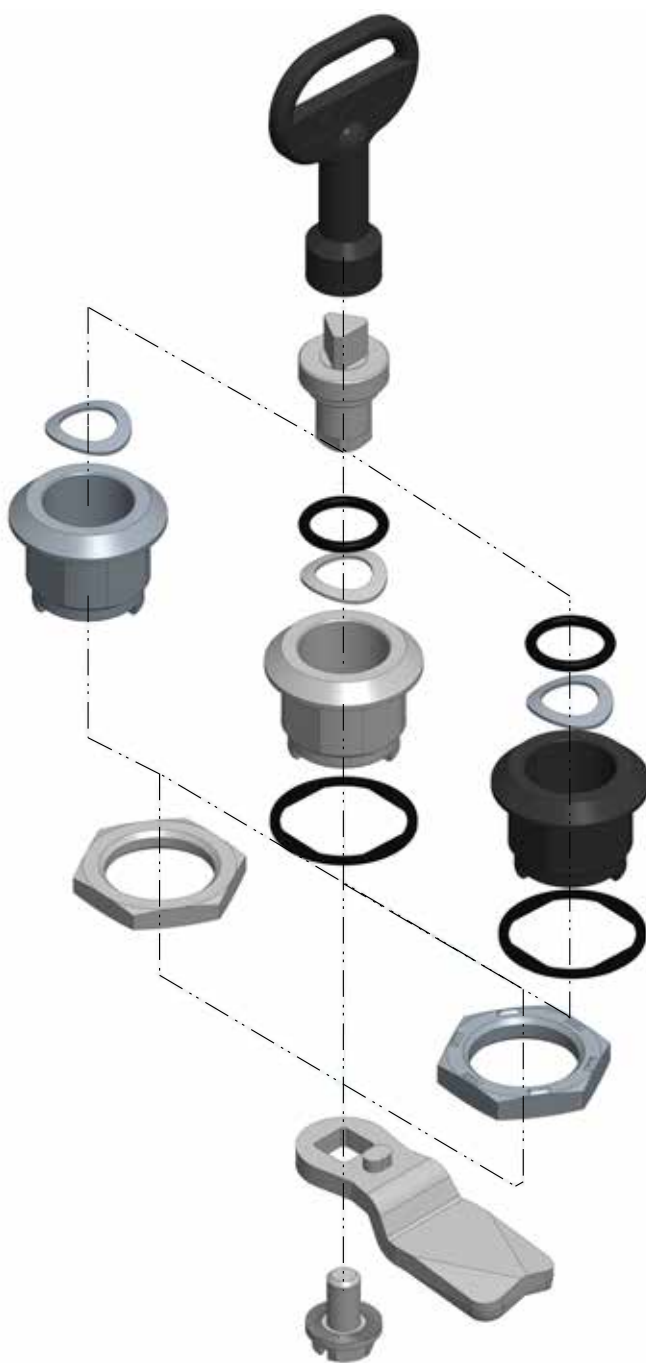
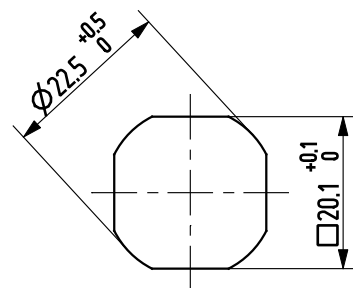
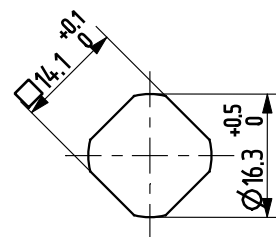



ZÁRHÁZAK



Zárházak

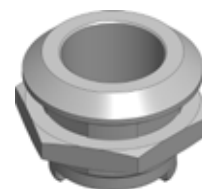
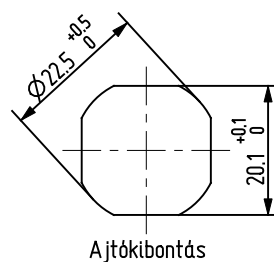
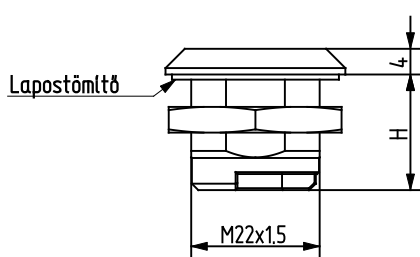
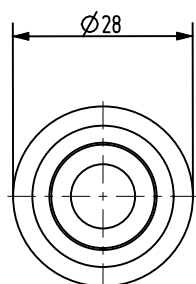

Termékszám	H (mm)	Alapanyag	Felületkezelés	Anyá alapanyag	Anyá felületkezelés
90KO-KH001-00	18	1.4305	-	1.4305	-
90KO-KH002-00	18	1.4571	-	1.4305	-
90KO-KH056-00	30	1.4305	-	1.4305	-
90KO-KH011-00	30	1.4571	-	1.4305	-
90KO-KH058-00	36	1.4305	-	1.4305	-
90KO-KH020-00	36	1.4571	-	1.4305	-
90KO-KH059-00	40	1.4305	-	1.4305	-
90KO-KH010-00	40	1.4571	-	1.4305	-
90KO-KH060-00	50	1.4305	-	1.4305	-
90KO-KH061-00	50	1.4571	-	1.4305	-
90KO-KH062-00	60	1.4305	-	1.4305	-
90KO-KH025-00	60	1.4571	-	1.4305	-

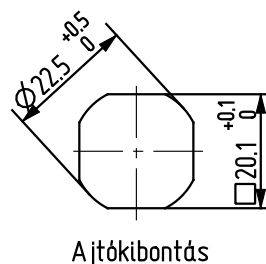
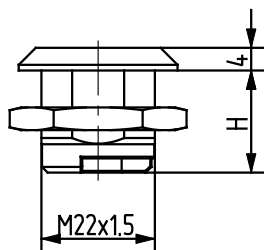
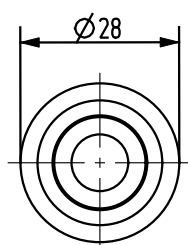

Megjegyzés:
*90PA-KH005-00
lapostömítővel

Termékszám	H (mm)	Alapanyag	Felületkezelés	Anyá alapanyag	Anyá felületkezelés
90PA-KH001-00	18	PA	-	ST	horganyozva
90PA-KH002-00	18	PA	-	cinköntvény	-
90PA-KH003-00	18	PA	-	PA	-
90PA-KH005-00*	18	PA	-	1.4305	-

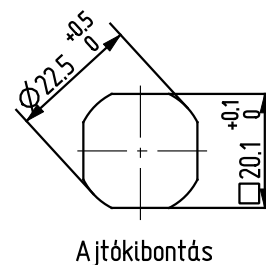
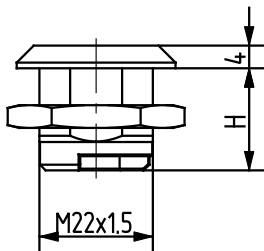
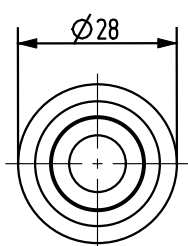

Megjegyzés:
*90ZA-KH005-04
földelőanyával

Termékszám	H (mm)	Alapanyag	Felületkezelés	Anyá alapanyag	Anyá felületkezelés
90ZA-KH001-04	18	cinköntvény	krómozott	cinköntvény	-
90ZA-KH005-04*	18	cinköntvény	krómozott	cinköntvény	-

Zárházak

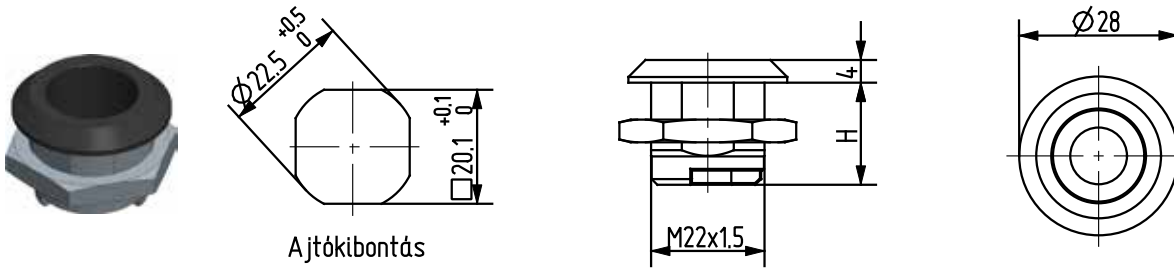

Ajtókibontás

Termékszám	H (mm)	Alapanyag	Felületkezelés	Anyá alapanyag	Anyá felületkezelés
90ZA-KH001-06	18	cinköntvény	fekete porszórt	cinköntvény	-
90ZA-KH005-06*	18	cinköntvény	fekete porszórt	cinköntvény	-

Megjegyzés:
*90ZA-KH005-06
földelőanyával

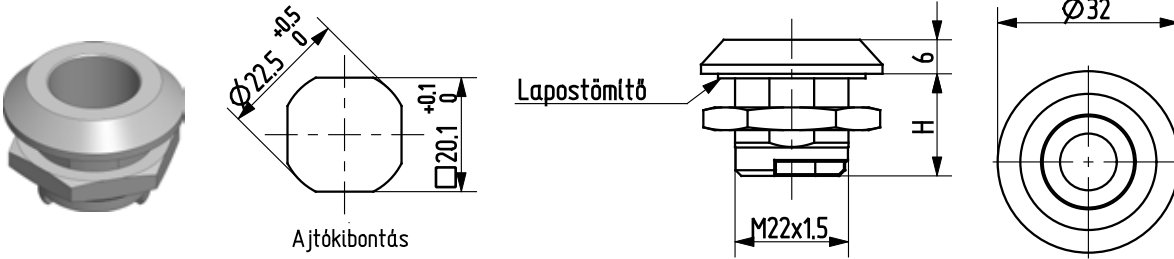

Ajtókibontás

Termékszám	H (mm)	Alapanyag	Felületkezelés	Anyá alapanyag	Anyá felületkezelés
90KO-KH003-00	18	1.4305	-	1.4305	-
90KO-KH066-00	18	1.4571	-	1.4305	-
90KO-KH004-00	30	1.4305	-	1.4305	-
90KO-KH067-00	30	1.4571	-	1.4305	-
90KO-KH005-00	36	1.4305	-	1.4305	-
90KO-KH068-00	36	1.4571	-	1.4305	-
90KO-KH006-00	40	1.4305	-	1.4305	-
90KO-KH069-00	40	1.4571	-	1.4305	-
90KO-KH007-00	50	1.4305	-	1.4305	-
90KO-KH070-00	50	1.4571	-	1.4305	-
90KO-KH008-00	60	1.4305	-	1.4305	-
90KO-KH071-00	60	1.4571	-	1.4305	-

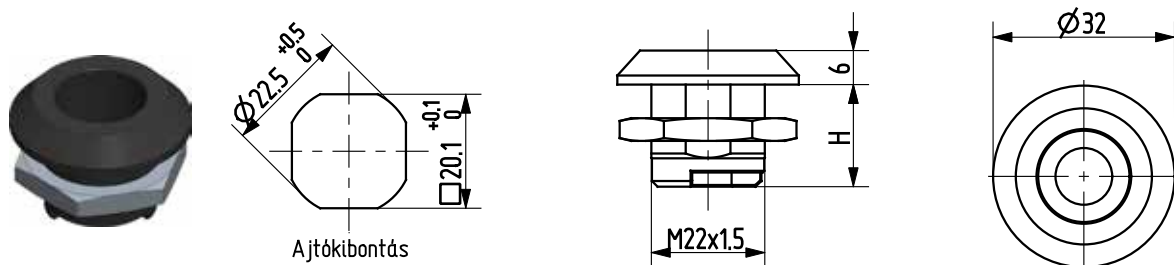

Ajtókibontás

Termékszám	H (mm)	Alapanyag	Felületkezelés	Anyá alapanyag	Anyá felületkezelés
90PA-KH013-00	18	PA	-	cinköntvény	-
90PA-KH004-00	30	PA	-	cinköntvény	-
90PA-KH012-00	36	PA	-	cinköntvény	-
90PA-KH006-00	40	PA	-	cinköntvény	-
90PA-KH008-00	50	PA	-	cinköntvény	-
90PA-KH011-00	60	PA	-	cinköntvény	-

Zárházak

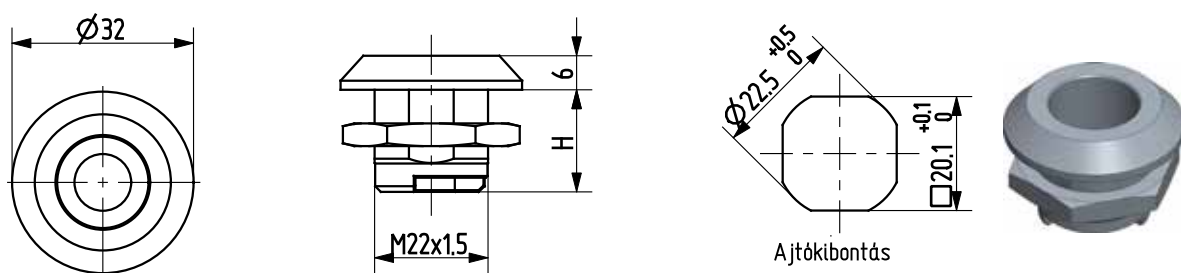

Termékszám	H (mm)	Alapanyag	Felületkezelés	Anyá alapanyag	Anyá felületkezelés
90ZA-KH003-04	18	cinköntvény	krómozott	cinköntvény	-
90ZA-KH006-04	30	cinköntvény	krómozott	cinköntvény	-
90ZA-KH012-04	36	cinköntvény	krómozott	cinköntvény	-
90ZA-KH008-04	40	cinköntvény	krómozott	cinköntvény	-
90ZA-KH009-04	50	cinköntvény	krómozott	cinköntvény	-
90ZA-KH007-04	60	cinköntvény	krómozott	cinköntvény	-

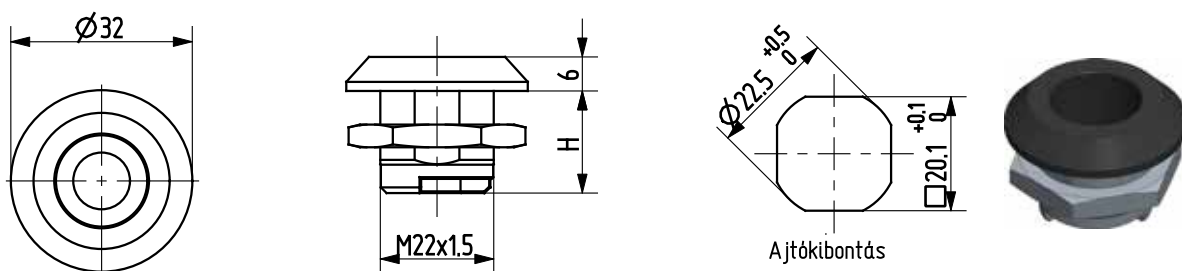

Termékszám	H (mm)	Alapanyag	Felületkezelés	Anyá alapanyag	Anyá felületkezelés
90ZA-KH003-06	18	cinköntvény	fekete porszórt	cinköntvény	-
90ZA-KH006-06	30	cinköntvény	fekete porszórt	cinköntvény	-
90ZA-KH012-06	36	cinköntvény	fekete porszórt	cinköntvény	-
90ZA-KH008-06	40	cinköntvény	fekete porszórt	cinköntvény	-
90ZA-KH009-06	50	cinköntvény	fekete porszórt	cinköntvény	-
90ZA-KH007-06	60	cinköntvény	fekete porszórt	cinköntvény	-

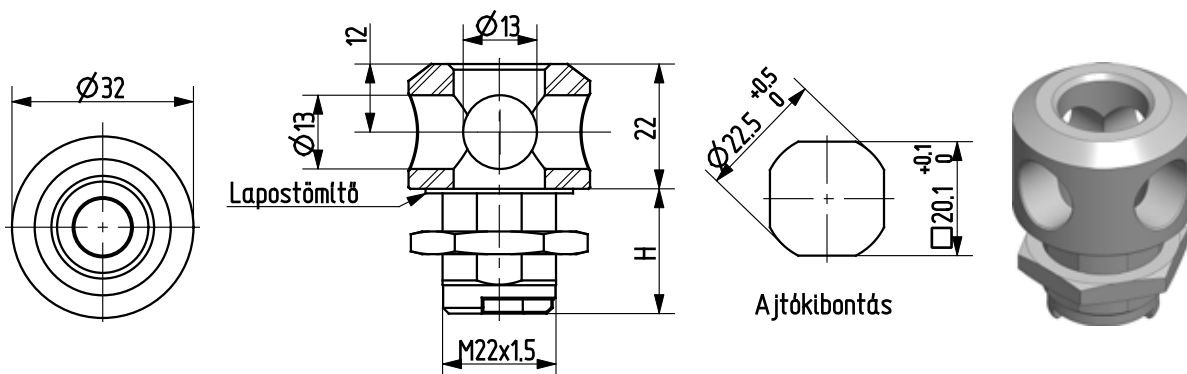

Termékszám	H (mm)	Alapanyag	Felületkezelés	Anyá alapanyag	Anyá felületkezelés
90KO-KH031-00	22	1.4305	-	1.4305	-
90KO-KH044-00	22	1.4571	-	1.4305	-

Zárházak

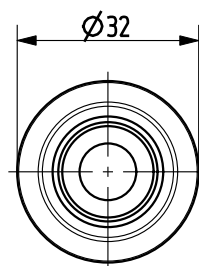
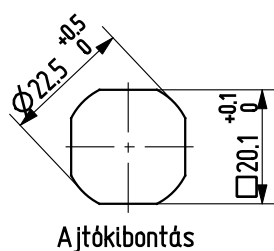
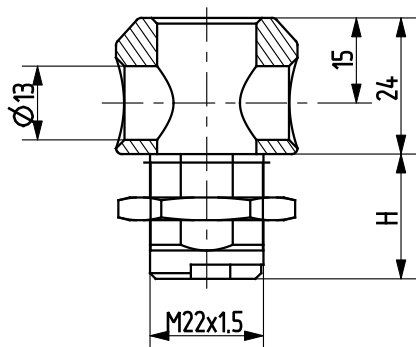

Ajtókibontás

Termékszám	H (mm)	Alapanyag	Felületkezelés	Anyá alapanyag	Anyá felületkezelés
90ZA-KH013-06	22	cinköntvény	fekete porszórt	cinköntvény	-
90ZA-KH014-06	32	cinköntvény	fekete porszórt	cinköntvény	-

Vasúti norma

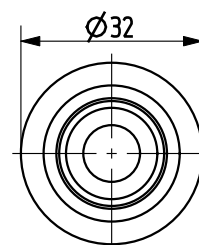
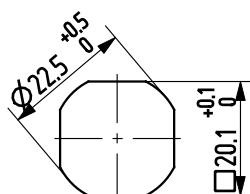
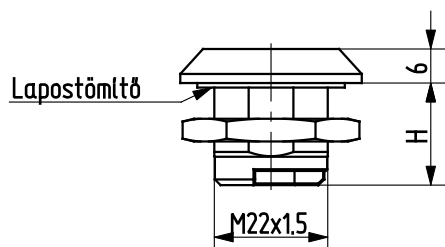
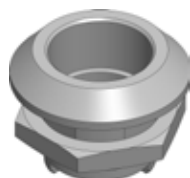

Ajtókibontás

Termékszám	H (mm)	Alapanyag	Felületkezelés	Anyá alapanyag	Anyá felületkezelés
90KO-KH017-00	18	1.4305	-	1.4305	-
90KO-KH045-00	18	1.4571	-	1.4305	-
90KO-KH046-00	30	1.4305	-	1.4305	-
90KO-KH047-00	30	1.4571	-	1.4305	-
90KO-KH048-00	36	1.4305	-	1.4305	-
90KO-KH049-00	36	1.4571	-	1.4305	-
90KO-KH050-00	40	1.4305	-	1.4305	-
90KO-KH051-00	40	1.4571	-	1.4305	-
90KO-KH052-00	50	1.4305	-	1.4305	-
90KO-KH053-00	50	1.4571	-	1.4305	-
90KO-KH054-00	60	1.4305	-	1.4305	-
90KO-KH055-00	60	1.4571	-	1.4305	-

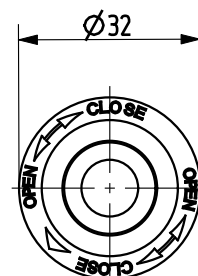
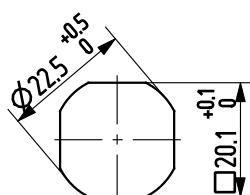
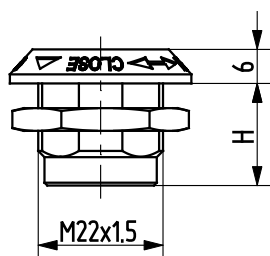

Ajtókibontás

Termékszám	H (mm)	Alapanyag	Felületkezelés	Anyá alapanyag	Anyá felületkezelés
90ZA-KH015-04	18	cinköntvény	krómozott	cinköntvény	-
90ZA-KH016-04	30	cinköntvény	krómozott	cinköntvény	-
90ZA-KH017-04	36	cinköntvény	krómozott	cinköntvény	-
90ZA-KH018-04	40	cinköntvény	krómozott	cinköntvény	-
90ZA-KH019-04	50	cinköntvény	krómozott	cinköntvény	-
90ZA-KH020-04	60	cinköntvény	krómozott	cinköntvény	-



Zárházak

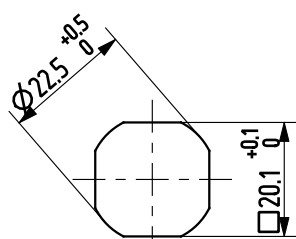
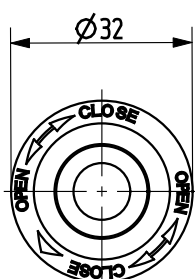

Ajtókibontás

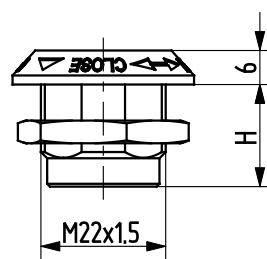

Termékszám	H (mm)	Alapanyag	Felületkezelés	Anyá alapanyag	Anyá felületkezelés
90ZA-KH015-06	18	cinköntvény	krómozott	cinköntvény	-
90ZA-KH016-06	30	cinköntvény	krómozott	cinköntvény	-
90ZA-KH017-06	36	cinköntvény	krómozott	cinköntvény	-
90ZA-KH018-06	40	cinköntvény	krómozott	cinköntvény	-
90ZA-KH019-06	50	cinköntvény	krómozott	cinköntvény	-
90ZA-KH020-06	60	cinköntvény	krómozott	cinköntvény	-

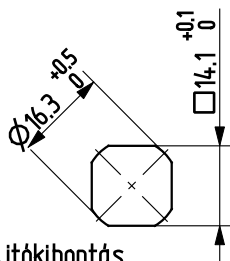
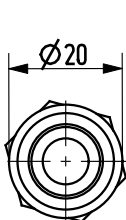

Ajtókibontás

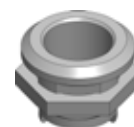
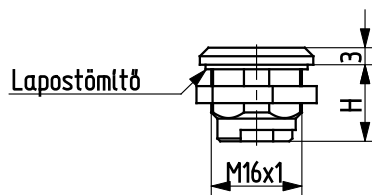

Termékszám	H (mm)	Alapanyag	Felületkezelés	Anyá alapanyag	Anyá felületkezelés
90KO-KH021-00	13.5	1.4305	-	1.4305	-
90KO-KH040-00	13.5	1.4571	-	1.4305	-

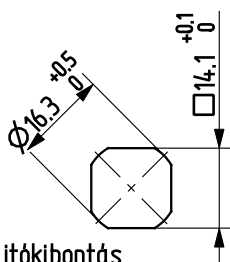
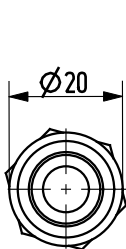

Ajtókibontás

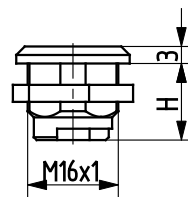

Termékszám	H (mm)	Alapanyag	Felületkezelés	Anyá alapanyag	Anyá felületkezelés
90ZA-KH004-04	13.5	cinköntvény	krómozott	cinköntvény	-

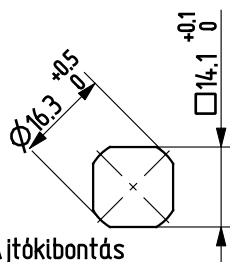
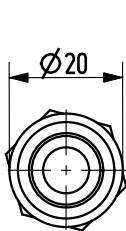

Ajtókibontás

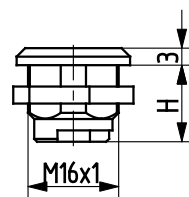

Termékszám	H (mm)	Alapanyag	Felületkezelés	Anyá alapanyag	Anyá felületkezelés
90ZA-KH004-06	13.5	cinköntvény	fekete porszórt	cinköntvény	-



ZÁRBETÉTEK



Zárbetétek

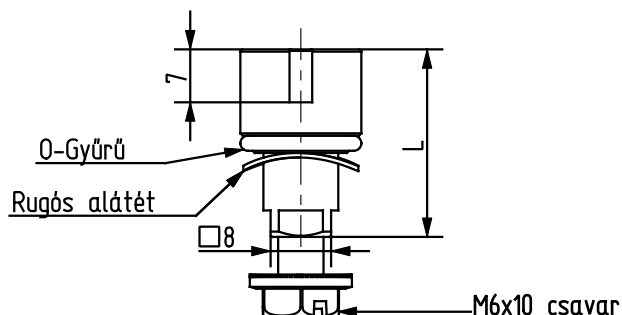
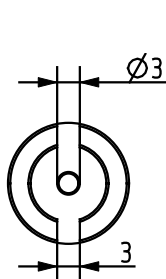

Termékszám	L (mm)	Alapanyag	Felületkezelés	Hozzá tartozó zárház beépítési mélysége (H) mm	Hozzárendelhető kulcs (Rövid verzió)	Hozzárendelhető kulcs (Hosszú verzió)
90KO-KB001-00	24.8	1.4305	-	18	90ZA-ZK008-06	90ZA-ZK011-06
90KO-KB009-00	24.8	1.4571	-	18	90ZA-ZK008-06	90ZA-ZK011-06
90KO-KB080-00	36.8	1.4305	-	30	90ZA-ZK008-06	90ZA-ZK011-06
90KO-KB081-00	36.8	1.4571	-	30	90ZA-ZK008-06	90ZA-ZK011-06
90KO-KB082-00	42.8	1.4305	-	36	90ZA-ZK008-06	90ZA-ZK011-06
90KO-KB083-00	42.8	1.4571	-	36	90ZA-ZK008-06	90ZA-ZK011-06
90KO-KB084-00	46.8	1.4305	-	40	90ZA-ZK008-06	90ZA-ZK011-06
90KO-KB085-00	46.8	1.4571	-	40	90ZA-ZK008-06	90ZA-ZK011-06
90KO-KB086-00	56.8	1.4305	-	50	90ZA-ZK008-06	90ZA-ZK011-06
90KO-KB087-00	56.8	1.4571	-	50	90ZA-ZK008-06	90ZA-ZK011-06
90KO-KB088-00	66.8	1.4305	-	60	90ZA-ZK008-06	90ZA-ZK011-06
90KO-KB089-00	66.8	1.4571	-	60	90ZA-ZK008-06	90ZA-ZK011-06

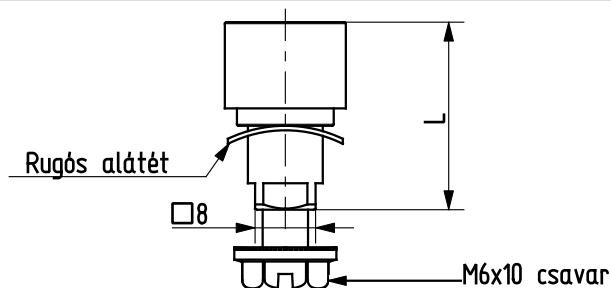
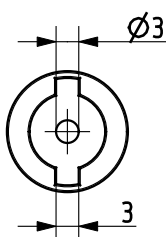

Termékszám	L (mm)	Alapanyag	Felületkezelés	Hozzá tartozó zárház beépítési mélysége (H) mm	Hozzárendelhető kulcs (Rövid verzió)	Hozzárendelhető kulcs (Hosszú verzió)
90PA-KB001-00	24.8	PA	-	18	90ZA-ZK008-06	90ZA-ZK011-06

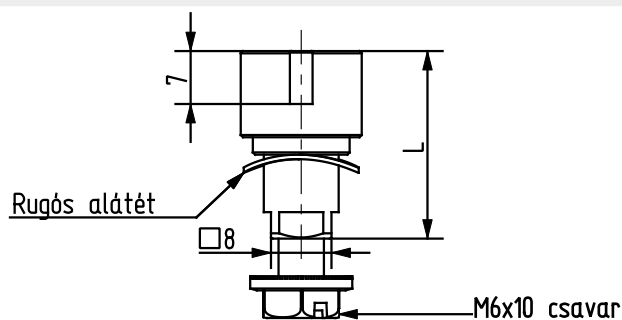
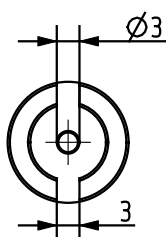

Termékszám	L (mm)	Alapanyag	Felületkezelés	Hozzá tartozó zárház beépítési mélysége (H) mm	Hozzárendelhető kulcs (Rövid verzió)	Hozzárendelhető kulcs (Hosszú verzió)
90ZA-KB001-04	24.8	cinköntvény	krómozva	18	90ZA-ZK008-06	90ZA-ZK011-06

Zárbetétek

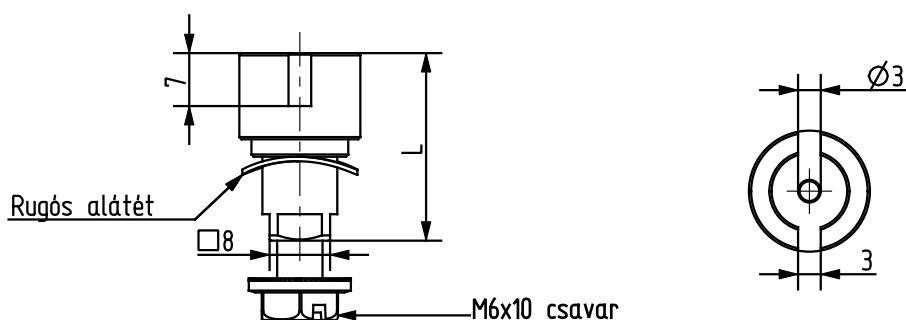

Termékszám	L (mm)	Alapanyag	Felületkezelés	Hozzá tartozó zárház beépítési mélysége (H) mm	Hozzárendelhető kulcs (Rövid verzió)	Hozzárendelhető kulcs (Hosszú verzió)
90ZA-KB001-06	24.8	cinköntvény	fekete porszórt	18	90ZA-ZK008-06	90ZA-ZK011-06

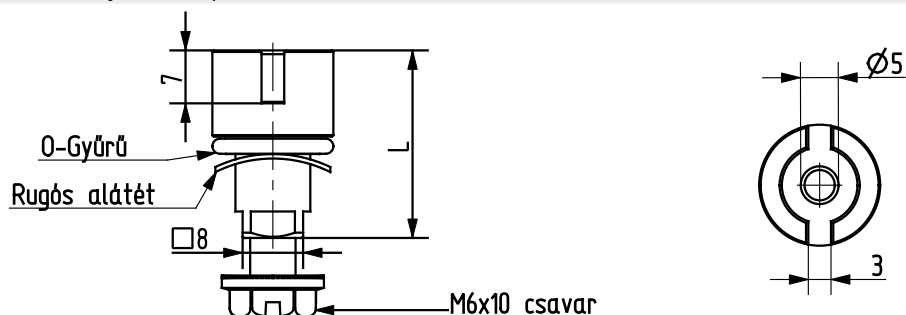

Termékszám	L (mm)	Alapanyag	Felületkezelés	Hozzá tartozó zárház beépítési mélysége (H) mm	Hozzárendelhető kulcs (Rövid verzió)	Hozzárendelhető kulcs (Hosszú verzió)
90KO-KB002-00	24.8	1.4305	-	18	90ZA-ZK009-06	90ZA-ZK012-06
90KO-KB003-00	24.8	1.4571	-	18	90ZA-ZK009-06	90ZA-ZK012-06
90KO-KB090-00	36.8	1.4305	-	30	90ZA-ZK009-06	90ZA-ZK012-06
90KO-KB091-00	36.8	1.4571	-	30	90ZA-ZK009-06	90ZA-ZK012-06
90KO-KB092-00	42.8	1.4305	-	36	90ZA-ZK009-06	90ZA-ZK012-06
90KO-KB093-00	42.8	1.4571	-	36	90ZA-ZK009-06	90ZA-ZK012-06
90KO-KB094-00	46.8	1.4305	-	40	90ZA-ZK009-06	90ZA-ZK012-06
90KO-KB095-00	46.8	1.4571	-	40	90ZA-ZK009-06	90ZA-ZK012-06
90KO-KB096-00	56.8	1.4305	-	50	90ZA-ZK009-06	90ZA-ZK012-06
90KO-KB097-00	56.8	1.4571	-	50	90ZA-ZK009-06	90ZA-ZK012-06
90KO-KB098-00	66.8	1.4305	-	60	90ZA-ZK009-06	90ZA-ZK012-06
90KO-KB099-00	66.8	1.4571	-	60	90ZA-ZK009-06	90ZA-ZK012-06

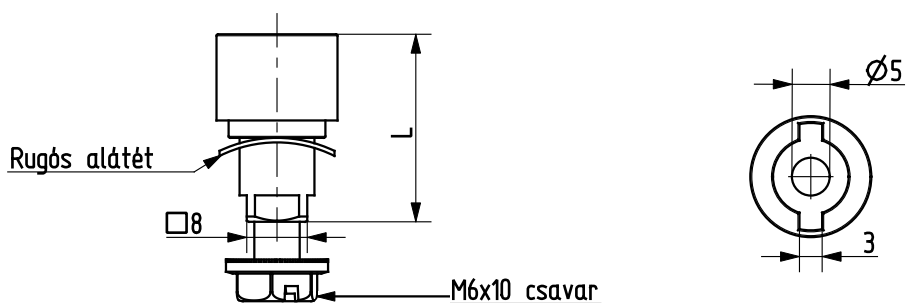

Termékszám	L (mm)	Alapanyag	Felületkezelés	Hozzá tartozó zárház beépítési mélysége (H) mm	Hozzárendelhető kulcs (Rövid verzió)	Hozzárendelhető kulcs (Hosszú verzió)
90PA-KB003-00	24.8	PA	-	18	90ZA-ZK009-06	90ZA-ZK012-06



Zárbetétek

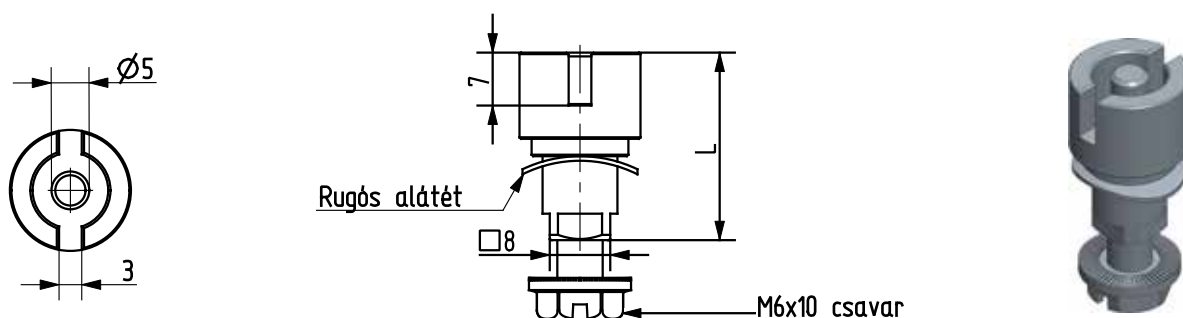

Termékszám	L (mm)	Alapanyag	Felületkezelés	Hozzá tartozó zárház beépítési mélysége (H) mm	Hozzárendelhető kulcs (Rövid verzió)	Hozzárendelhető kulcs (Hosszú verzió)
90ZA-KB003-04	24.8	cinköntvény	krómozva	18	90ZA-ZK009-06	90ZA-ZK012-06

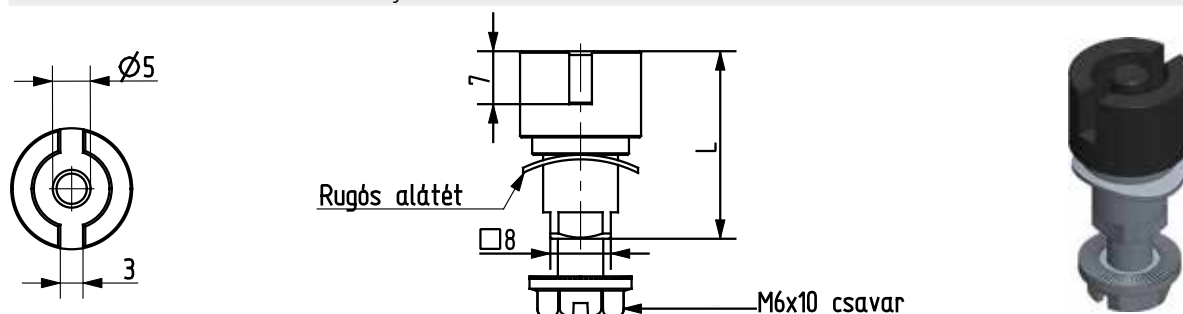

Termékszám	L (mm)	Alapanyag	Felületkezelés	Hozzá tartozó zárház beépítési mélysége (H) mm	Hozzárendelhető kulcs (Rövid verzió)	Hozzárendelhető kulcs (Hosszú verzió)
90ZA-KB003-06	24.8	cinköntvény	fekete porszórt	18	90ZA-ZK009-06	90ZA-ZK012-06

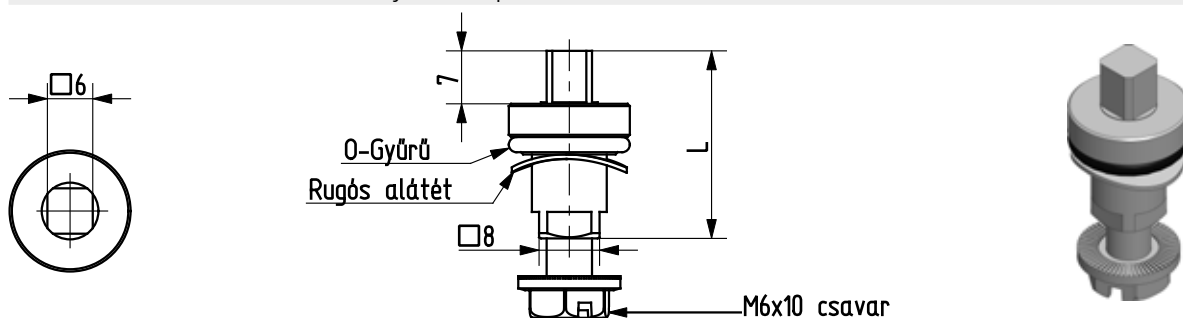

Termékszám	L (mm)	Alapanyag	Felületkezelés	Hozzá tartozó zárház beépítési mélysége (H) mm	Hozzárendelhető kulcs
90KO-KB004-00	24.8	1.4305	-	18	90ZA-ZK001-06
90KO-KB063-00	24.8	1.4571	-	18	90ZA-ZK001-06
90KO-KB120-00	36.8	1.4305	-	30	90ZA-ZK001-06
90KO-KB121-00	36.8	1.4571	-	30	90ZA-ZK001-06
90KO-KB122-00	42.8	1.4305	-	36	90ZA-ZK001-06
90KO-KB123-00	42.8	1.4571	-	36	90ZA-ZK001-06
90KO-KB124-00	46.8	1.4305	-	40	90ZA-ZK001-06
90KO-KB125-00	46.8	1.4571	-	40	90ZA-ZK001-06
90KO-KB126-00	56.8	1.4305	-	50	90ZA-ZK001-06
90KO-KB127-00	56.8	1.4571	-	50	90ZA-ZK001-06
90KO-KB128-00	66.8	1.4305	-	60	90ZA-ZK001-06
90KO-KB129-00	66.8	1.4571	-	60	90ZA-ZK001-06



Zárbetétek

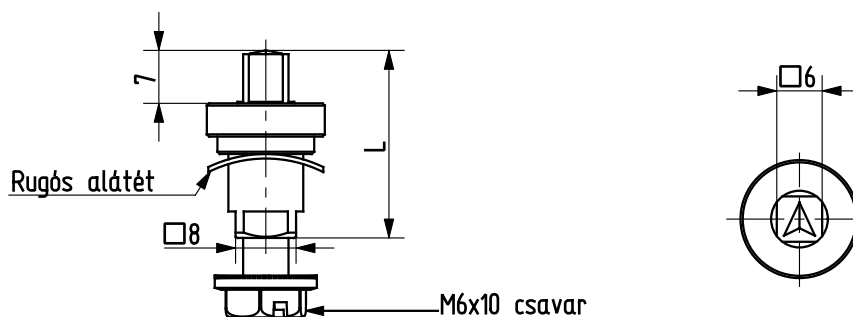

Termékszám	L (mm)	Alapanyag	Felületkezelés	Hozzá tartozó zárház beépítési mélysége (H) mm	Hozzárendelhető kulcs
90ZA-KB024-04	24.8	cinköntvény	krómozva	18	90ZA-ZK001-06

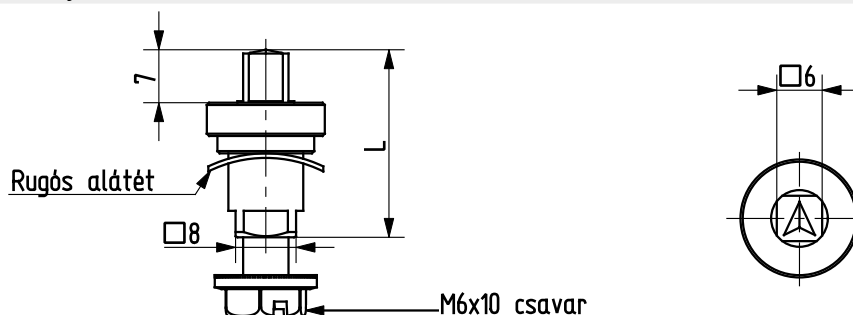

Termékszám	L (mm)	Alapanyag	Felületkezelés	Hozzá tartozó zárház beépítési mélysége (H) mm	Hozzárendelhető kulcs
90ZA-KB024-06	24.8	cinköntvény	fekete porszórt	18	90ZA-ZK001-06

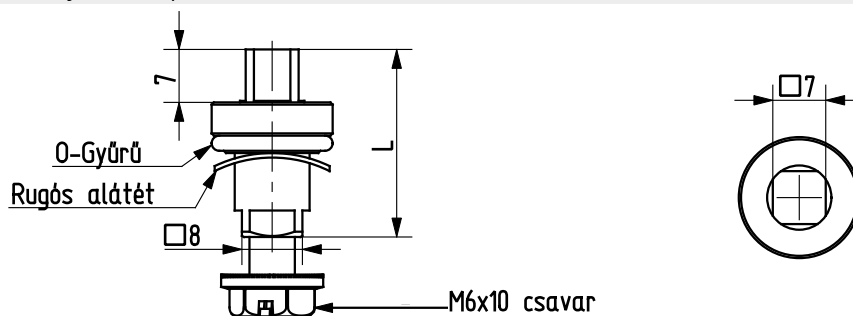

Termékszám	L (mm)	Alapanyag	Felületkezelés	Hozzá tartozó zárház beépítési mélysége (H) mm	Hozzárendelhető kulcs
90KO-KB005-00	24.8	1.4305	-	18	90ZA-ZK002-06
90KO-KB064-00	24.8	1.4571	-	18	90ZA-ZK002-06
90KO-KB110-00	36.8	1.4305	-	30	90ZA-ZK002-06
90KO-KB111-00	36.8	1.4571	-	30	90ZA-ZK002-06
90KO-KB112-00	42.8	1.4305	-	36	90ZA-ZK002-06
90KO-KB113-00	42.8	1.4571	-	36	90ZA-ZK002-06
90KO-KB114-00	46.8	1.4305	-	40	90ZA-ZK002-06
90KO-KB115-00	46.8	1.4571	-	40	90ZA-ZK002-06
90KO-KB116-00	56.8	1.4305	-	50	90ZA-ZK002-06
90KO-KB117-00	56.8	1.4571	-	50	90ZA-ZK002-06
90KO-KB118-00	66.8	1.4305	-	60	90ZA-ZK002-06
90KO-KB119-00	66.8	1.4571	-	60	90ZA-ZK002-06



Zárbetétek

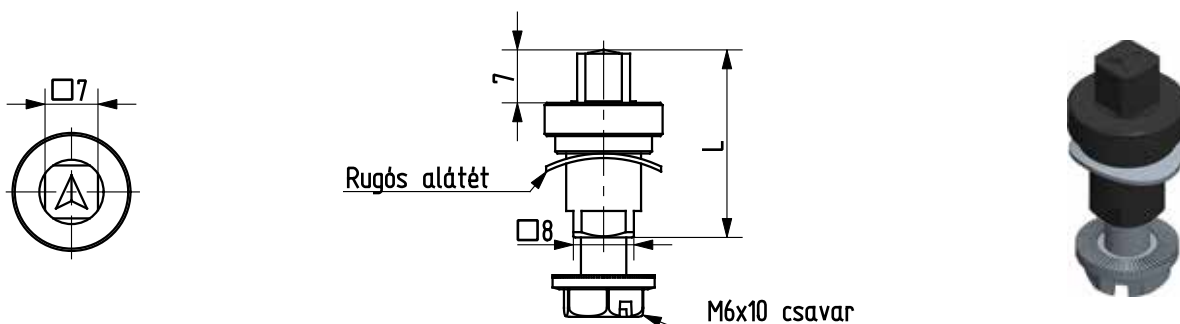

Termékszám	L (mm)	Alapanyag	Felületkezelés	Hozzá tartozó zárház beépítési mélysége (H) mm	Hozzárendelhető kulcs
90PA-KB023-00	24.8	PA	-	18	90ZA-ZK002-06

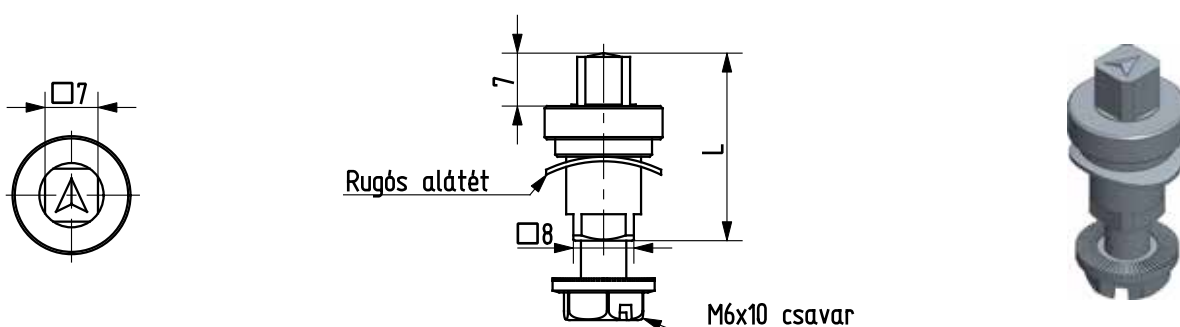

Termékszám	L (mm)	Alapanyag	Felületkezelés	Hozzá tartozó zárház beépítési mélysége (H) mm	Hozzárendelhető kulcs
90ZA-KB023-04	24.8	cinköntvény	krómozva	18	90ZA-ZK002-06

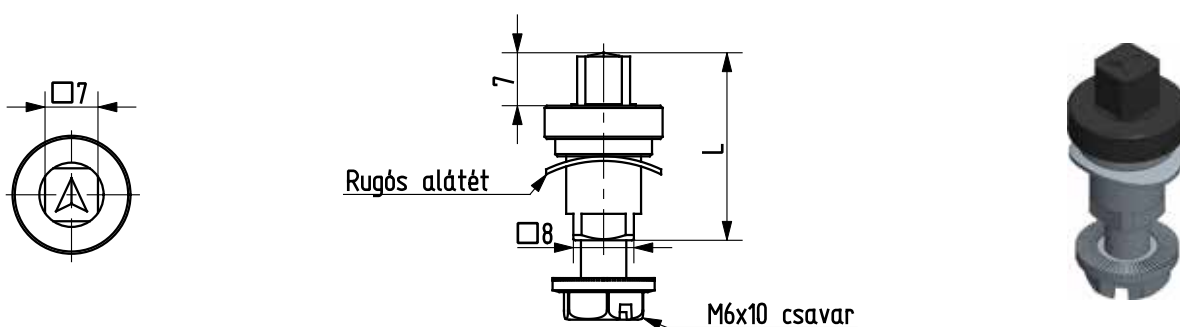

Termékszám	L (mm)	Alapanyag	Felületkezelés	Hozzá tartozó zárház beépítési mélysége (H) mm	Hozzárendelhető kulcs
90ZA-KB023-06	24.8	cinköntvény	fekete porszórt	18	90ZA-ZK002-06

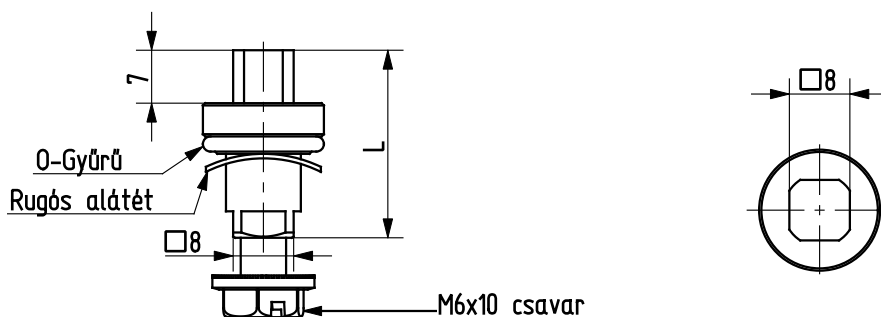

Termékszám	L (mm)	Alapanyag	Felületkezelés	Hozzá tartozó zárház beépítési mélysége (H) mm	Hozzárendelhető kulcs
90KO-KB006-00	24.8	1.4305	-	18	90ZA-ZK003-06
90KO-KB007-00	24.8	1.4571	-	18	90ZA-ZK003-06
90KO-KB100-00	36.8	1.4305	-	30	90ZA-ZK003-06
90KO-KB101-00	36.8	1.4571	-	30	90ZA-ZK003-06
90KO-KB102-00	42.8	1.4305	-	36	90ZA-ZK003-06
90KO-KB103-00	42.8	1.4571	-	36	90ZA-ZK003-06
90KO-KB104-00	46.8	1.4305	-	40	90ZA-ZK003-06
90KO-KB105-00	46.8	1.4571	-	40	90ZA-ZK003-06
90KO-KB106-00	56.8	1.4305	-	50	90ZA-ZK003-06
90KO-KB107-00	56.8	1.4571	-	50	90ZA-ZK003-06
90KO-KB108-00	66.8	1.4305	-	60	90ZA-ZK003-06
90KO-KB109-00	66.8	1.4571	-	60	90ZA-ZK003-06

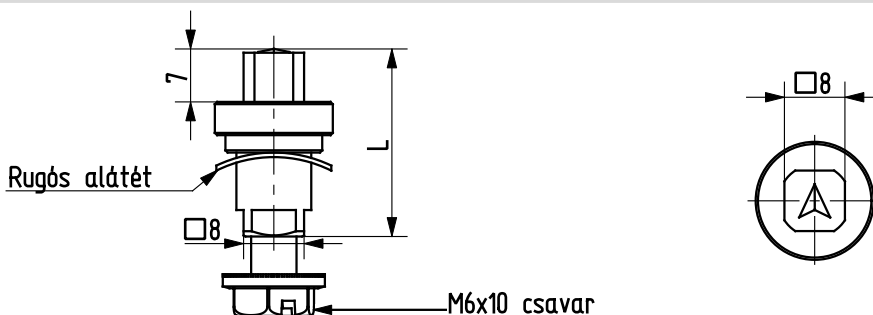

Termékszám	L (mm)	Alapanyag	Felületkezelés	Hozzá tartozó zárház beépítési mélysége (H) mm	Hozzárendelhető kulcs
90PA-KB008-00	24.8	PA	-	18	90ZA-ZK003-06

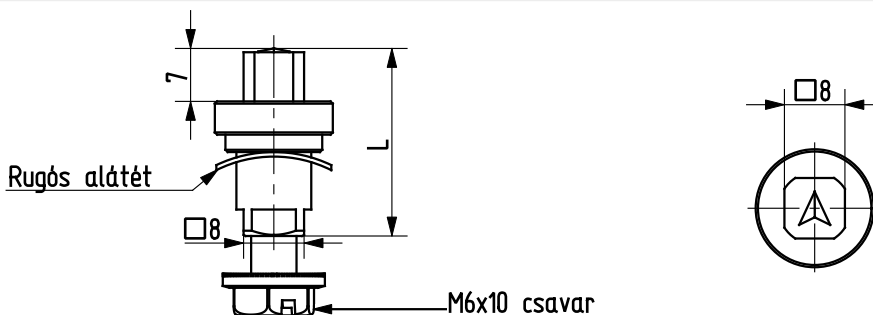

Termékszám	L (mm)	Alapanyag	Felületkezelés	Hozzá tartozó zárház beépítési mélysége (H) mm	Hozzárendelhető kulcs
90ZA-KB008-04	24.8	cinköntvény	krómozva	18	90ZA-ZK003-06

Zárbetétek

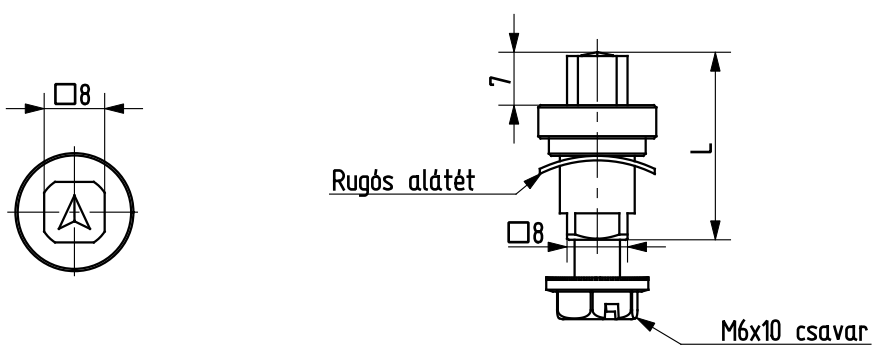

Termékszám	L (mm)	Alapanyag	Felületkezelés	Hozzá tartozó zárház beépítési mélysége (H) mm	Hozzárendelhető kulcs
90ZA-KB008-06	24.8	cinköntvény	fekete porszórt	18	90ZA-ZK003-06

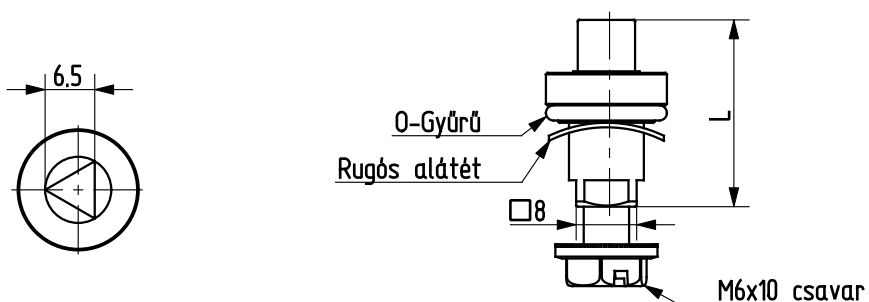

Termékszám	L (mm)	Alapanyag	Felületkezelés	Hozzá tartozó zárház beépítési mélysége (H) mm	Hozzárendelhető kulcs
90KO-KB236-00	24.8	1.4305	-	18	90ZA-ZK005-06
90KO-KB237-00	24.8	1.4571	-	18	90ZA-ZK005-06
90KO-KB150-00	36.8	1.4305	-	30	90ZA-ZK005-06
90KO-KB151-00	36.8	1.4571	-	30	90ZA-ZK005-06
90KO-KB152-00	42.8	1.4305	-	36	90ZA-ZK005-06
90KO-KB153-00	42.8	1.4571	-	36	90ZA-ZK005-06
90KO-KB154-00	46.8	1.4305	-	40	90ZA-ZK005-06
90KO-KB155-00	46.8	1.4571	-	40	90ZA-ZK005-06
90KO-KB156-00	56.8	1.4305	-	50	90ZA-ZK005-06
90KO-KB157-00	56.8	1.4571	-	50	90ZA-ZK005-06
90KO-KB158-00	66.8	1.4305	-	60	90ZA-ZK005-06
90KO-KB159-00	66.8	1.4571	-	60	90ZA-ZK005-06

Zárbetétek

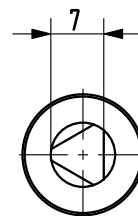
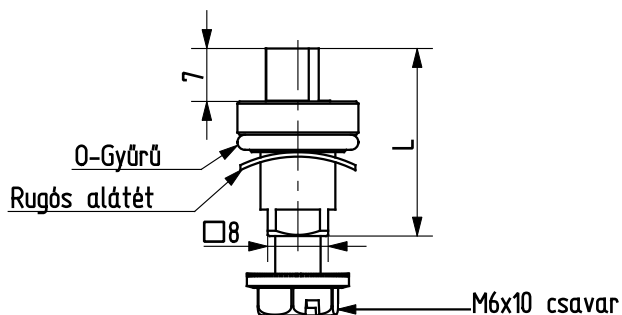

Termékszám	L (mm)	Alapanyag	Felületkezelés	Hozzá tartozó zárház beépítési mélysége (H) mm	Hozzárendelhető kulcs
90KO-KB011-00	24.8	1.4305	-	18	90ZA-ZK004-06
90KO-KB031-00	24.8	1.4571	-	18	90ZA-ZK004-06
90KO-KB140-00	36.8	1.4305	-	30	90ZA-ZK004-06
90KO-KB141-00	36.8	1.4571	-	30	90ZA-ZK004-06
90KO-KB142-00	42.8	1.4305	-	36	90ZA-ZK004-06
90KO-KB143-00	42.8	1.4571	-	36	90ZA-ZK004-06
90KO-KB144-00	46.8	1.4305	-	40	90ZA-ZK004-06
90KO-KB145-00	46.8	1.4571	-	40	90ZA-ZK004-06
90KO-KB146-00	56.8	1.4305	-	50	90ZA-ZK004-06
90KO-KB147-00	56.8	1.4571	-	50	90ZA-ZK004-06
90KO-KB148-00	66.8	1.4305	-	60	90ZA-ZK004-06
90KO-KB149-00	66.8	1.4571	-	60	90ZA-ZK004-06

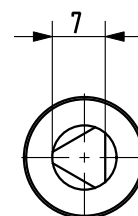
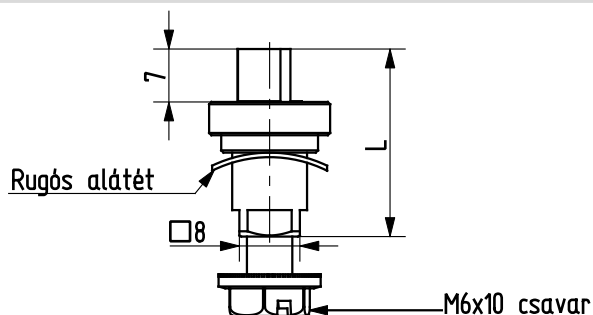

Termékszám	L (mm)	Alapanyag	Felületkezelés	Hozzá tartozó zárház beépítési mélysége (H) mm	Hozzárendelhető kulcs
90PA-KB011-00	24.8	PA	-	18	90ZA-ZK004-06

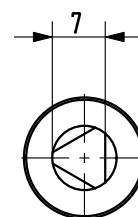
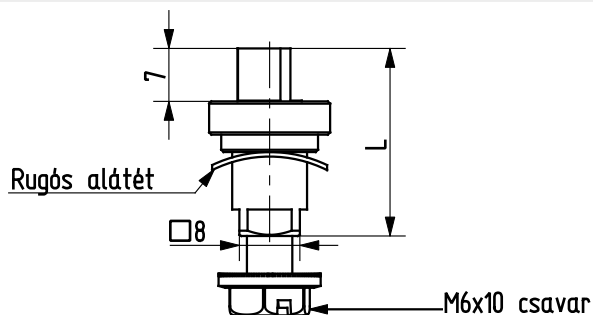

Termékszám	L (mm)	Alapanyag	Felületkezelés	Hozzá tartozó zárház beépítési mélysége (H) mm	Hozzárendelhető kulcs
90ZA-KB011-04	24.8	cinköntvény	krómozva	18	90ZA-ZK004-06

Zárbetétek

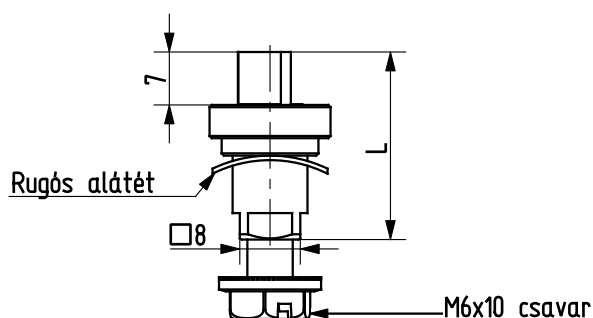
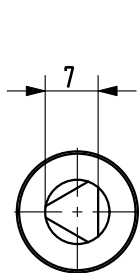

Termékszám	L (mm)	Alapanyag	Felületkezelés	Hozzá tartozó zárház beépítési mélysége (H) mm	Hozzárendelhető kulcs
90ZA-KB011-06	24.8	cinköntvény	fekete porszórt	18	90ZA-ZK004-06

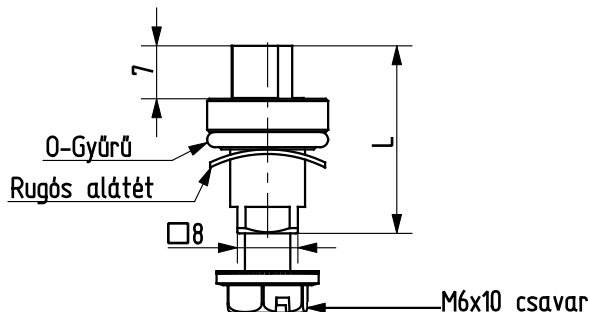
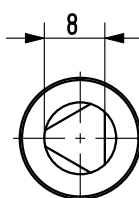

Termékszám	L (mm)	Alapanyag	Felületkezelés	Hozzá tartozó zárház beépítési mélysége (H) mm	Hozzárendelhető kulcs
90KO-KB012-00	24.8	1.4305	-	18	90ZA-ZK006-06
90KO-KB065-00	24.8	1.4571	-	18	90ZA-ZK006-06
90KO-KB160-00	36.8	1.4305	-	30	90ZA-ZK006-06
90KO-KB161-00	36.8	1.4571	-	30	90ZA-ZK006-06
90KO-KB162-00	42.8	1.4305	-	36	90ZA-ZK006-06
90KO-KB163-00	42.8	1.4571	-	36	90ZA-ZK006-06
90KO-KB164-00	46.8	1.4305	-	40	90ZA-ZK006-06
90KO-KB165-00	46.8	1.4571	-	40	90ZA-ZK006-06
90KO-KB166-00	56.8	1.4305	-	50	90ZA-ZK006-06
90KO-KB167-00	56.8	1.4571	-	50	90ZA-ZK006-06
90KO-KB168-00	66.8	1.4305	-	60	90ZA-ZK006-06
90KO-KB169-00	66.8	1.4571	-	60	90ZA-ZK006-06

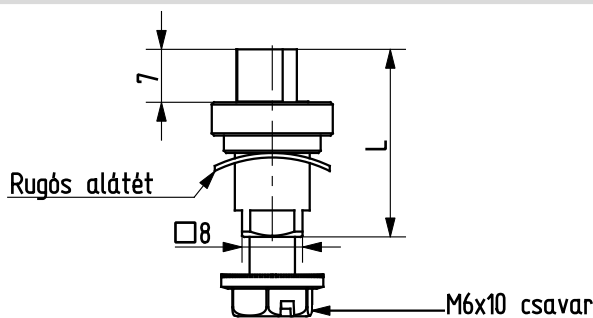
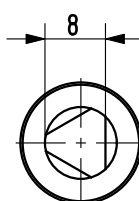

Termékszám	L (mm)	Alapanyag	Felületkezelés	Hozzá tartozó zárház beépítési mélysége (H) mm	Hozzárendelhető kulcs
90PA-KB012-00	24.8	PA	-	18	90ZA-ZK006-06

Zárbetétek

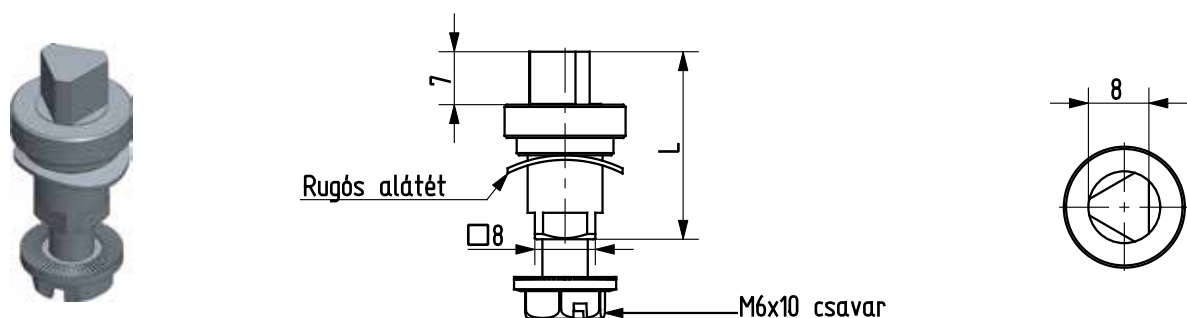

Termékszám	L (mm)	Alapanyag	Felületkezelés	Hozzá tartozó zárház beépítési mélysége (H) mm	Hozzárendelhető kulcs
90ZA-KB012-04	24.8	cinköntvény	krómozva	18	90ZA-ZK006-06

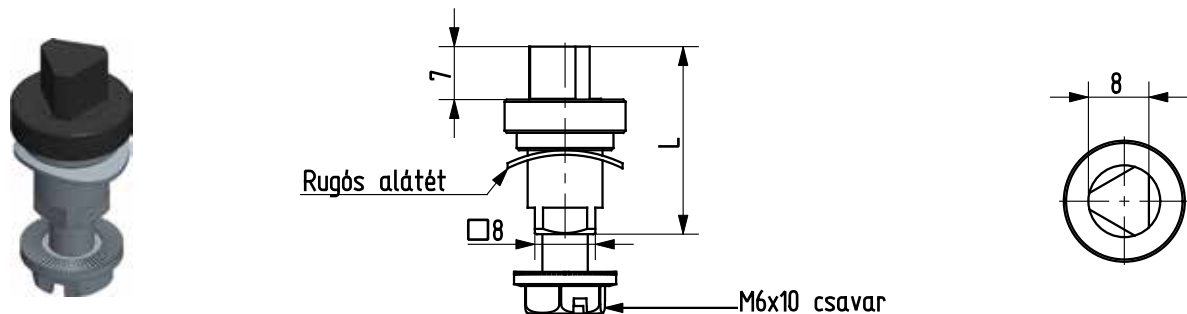

Termékszám	L (mm)	Alapanyag	Felületkezelés	Hozzá tartozó zárház beépítési mélysége (H) mm	Hozzárendelhető kulcs
90ZA-KB012-06	24.8	cinköntvény	fekete porszórt	18	90ZA-ZK006-06

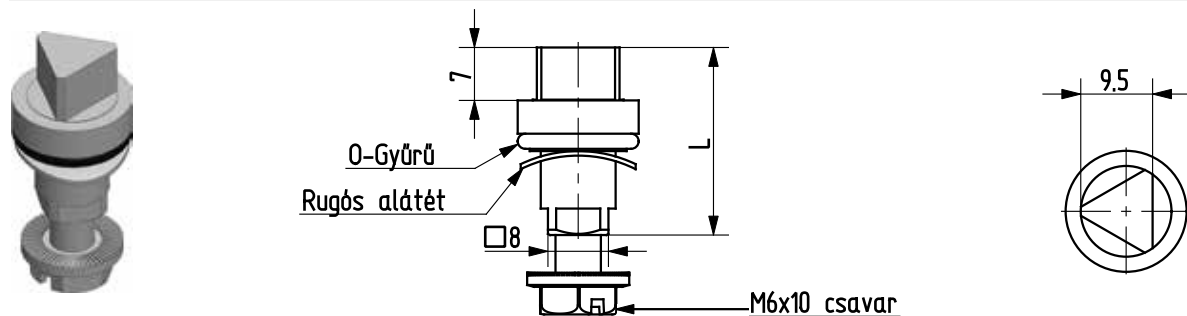

Termékszám	L (mm)	Alapanyag	Felületkezelés	Hozzá tartozó zárház beépítési mélysége (H) mm	Hozzárendelhető kulcs
90KO-KB070-00	24.8	1.4305	-	18	90ZA-ZK007-06
90KO-KB071-00	24.8	1.4571	-	18	90ZA-ZK007-06
90KO-KB170-00	36.8	1.4305	-	18	90ZA-ZK007-06
90KO-KB171-00	36.8	1.4571	-	18	90ZA-ZK007-06
90KO-KB172-00	42.8	1.4305	-	36	90ZA-ZK007-06
90KO-KB173-00	42.8	1.4571	-	36	90ZA-ZK007-06
90KO-KB174-00	46.8	1.4305	-	40	90ZA-ZK007-06
90KO-KB175-00	46.8	1.4571	-	40	90ZA-ZK007-06
90KO-KB176-00	56.8	1.4305	-	50	90ZA-ZK007-06
90KO-KB177-00	56.8	1.4571	-	50	90ZA-ZK007-06
90KO-KB178-00	66.8	1.4305	-	60	90ZA-ZK007-06
90KO-KB179-00	66.8	1.4571	-	60	90ZA-ZK007-06



Zárbetétek

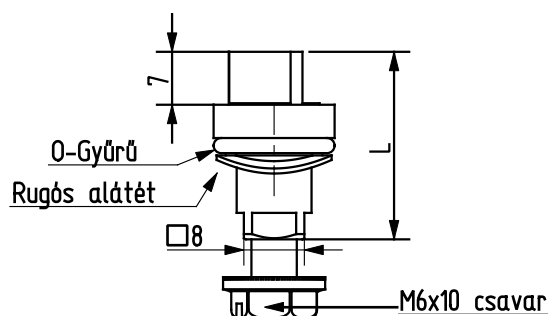
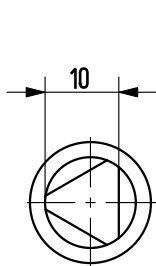

Termékszám	L (mm)	Alapanyag	Felületkezelés	Hozzá tartozó zárház beépítési mélysége (H) mm	Hozzárendelhető kulcs
90KO-KB072-00	24.8	1.4305	-	18	90ZA-ZK007-06
90KO-KB073-00	24.8	1.4571	-	18	90ZA-ZK007-06
90KO-KB210-00	36.8	1.4305	-	30	90ZA-ZK007-06
90KO-KB211-00	36.8	1.4571	-	30	90ZA-ZK007-06
90KO-KB212-00	42.8	1.4305	-	36	90ZA-ZK007-06
90KO-KB213-00	42.8	1.4571	-	36	90ZA-ZK007-06
90KO-KB214-00	46.8	1.4305	-	40	90ZA-ZK007-06
90KO-KB215-00	46.8	1.4571	-	40	90ZA-ZK007-06
90KO-KB216-00	56.8	1.4305	-	50	90ZA-ZK007-06
90KO-KB217-00	56.8	1.4571	-	50	90ZA-ZK007-06
90KO-KB218-00	66.8	1.4305	-	60	90ZA-ZK007-06
90KO-KB219-00	66.8	1.4571	-	60	90ZA-ZK007-06

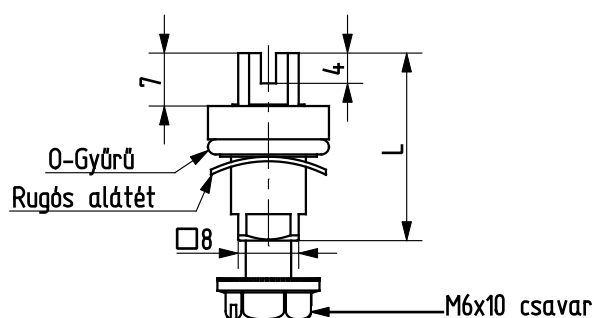
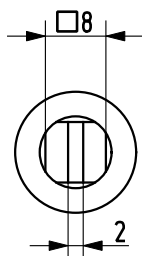

Termékszám	L (mm)	Alapanyag	Felületkezelés	Hozzá tartozó zárház beépítési mélysége (H) mm	Hozzárendelhető kulcs
90KO-KB058-00	24.8	1.4305	-	18	90ZA-ZK003-06
90KO-KB008-00	24.8	1.4571	-	18	90ZA-ZK003-06
90KO-KB130-00	36.8	1.4305	-	30	90ZA-ZK003-06
90KO-KB131-00	36.8	1.4571	-	30	90ZA-ZK003-06
90KO-KB132-00	42.8	1.4305	-	36	90ZA-ZK003-06
90KO-KB133-00	42.8	1.4571	-	36	90ZA-ZK003-06
90KO-KB134-00	46.8	1.4305	-	40	90ZA-ZK003-06
90KO-KB135-00	46.8	1.4571	-	40	90ZA-ZK003-06
90KO-KB136-00	56.8	1.4305	-	50	90ZA-ZK003-06
90KO-KB137-00	56.8	1.4571	-	50	90ZA-ZK003-06
90KO-KB138-00	66.8	1.4305	-	60	90ZA-ZK003-06
90KO-KB139-00	66.8	1.4571	-	60	90ZA-ZK003-06

Zárbetétek

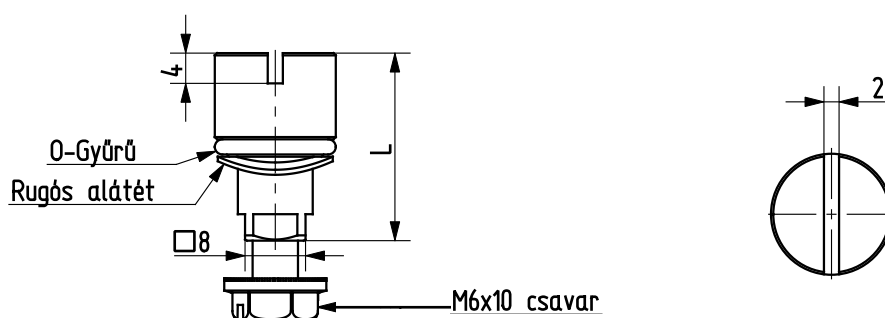

Termékszám	L (mm)	Alapanyag	Felületkezelés	Hozzá tartozó zárház beépítési mélysége (H) mm
90KO-KB019-00	24.8	1.4305	-	18
90KO-KB069-00	24.8	1.4571	-	18
90KO-KB180-00	36.8	1.4305	-	30
90KO-KB181-00	36.8	1.4571	-	30
90KO-KB182-00	42.8	1.4305	-	36
90KO-KB183-00	42.8	1.4571	-	36
90KO-KB184-00	46.8	1.4305	-	40
90KO-KB185-00	46.8	1.4571	-	40
90KO-KB186-00	56.8	1.4305	-	50
90KO-KB187-00	56.8	1.4571	-	50
90KO-KB188-00	66.8	1.4305	-	60
90KO-KB189-00	66.8	1.4571	-	60

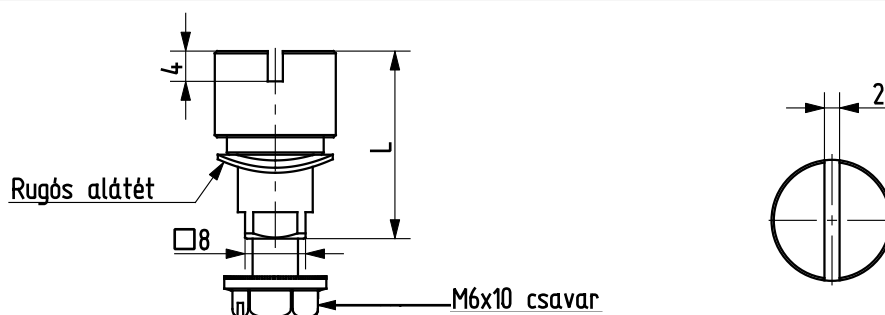

Termékszám	L (mm)	Alapanyag	Felületkezelés	Hozzá tartozó zárház beépítési mélysége (H) mm
90PA-KB009-00	24.8	PA	-	18

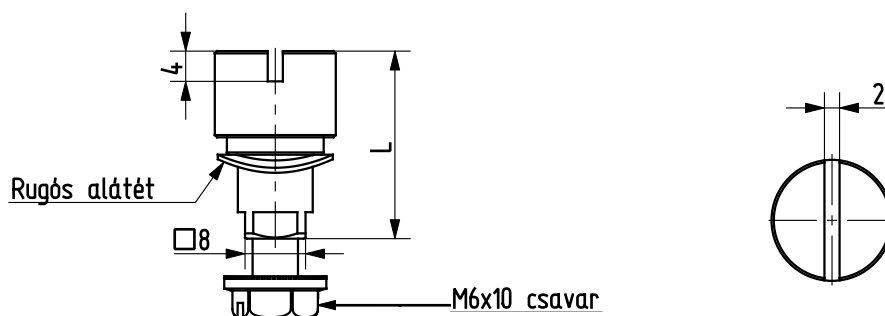

Termékszám	L (mm)	Alapanyag	Felületkezelés	Hozzá tartozó zárház beépítési mélysége (H) mm
90ZA-KB009-04	24.8	cinköntvény	krómozva	18

Zárbetétek

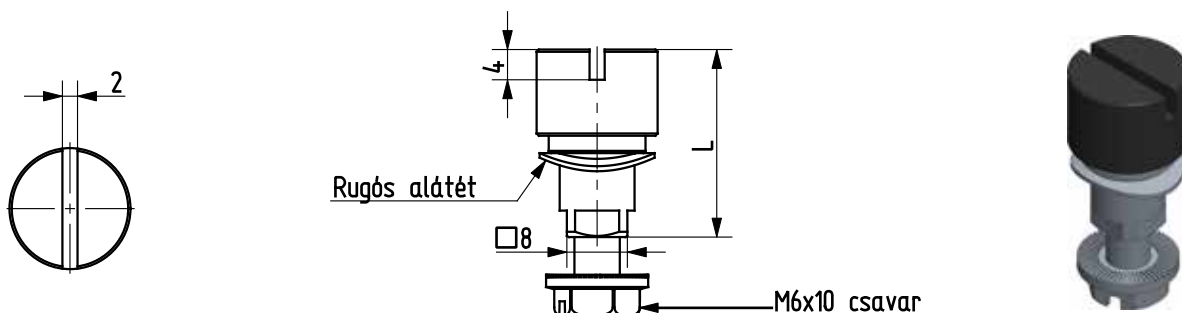

Termékszám	L (mm)	Alapanyag	Felületkezelés	Hozzá tartozó zárház beépítési mélysége (H) mm
90ZA-KB009-06	24.8	cinköntvény	fekete porszórt	18

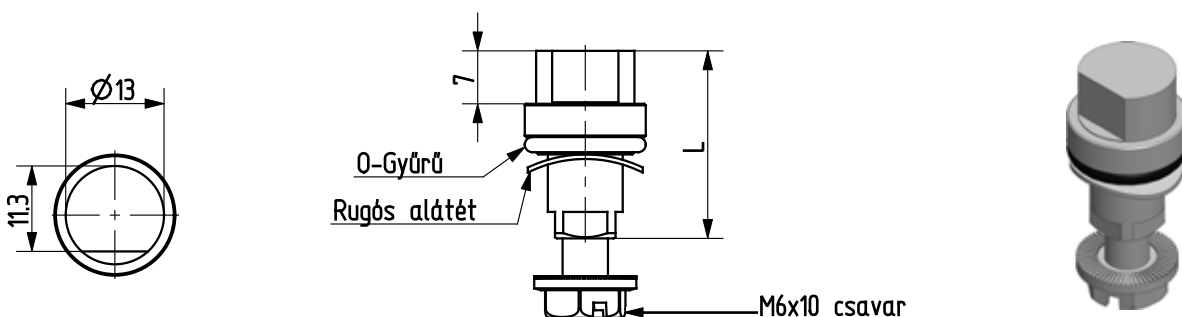

Termékszám	L (mm)	Alapanyag	Felületkezelés	Hozzá tartozó zárház beépítési mélysége (H) mm	Hozzárendelhető kulcs
90KO-KB055-00	24.8	1.4305	-	18	Külön rendelésre
90KO-KB240-00	24.8	1.4571	-	18	Külön rendelésre
90KO-KB200-00	36.8	1.4305	-	30	Külön rendelésre
90KO-KB201-00	36.8	1.4571	-	30	Külön rendelésre
90KO-KB202-00	42.8	1.4305	-	36	Külön rendelésre
90KO-KB203-00	42.8	1.4571	-	36	Külön rendelésre
90KO-KB204-00	46.8	1.4305	-	40	Külön rendelésre
90KO-KB205-00	46.8	1.4571	-	40	Külön rendelésre
90KO-KB206-00	56.8	1.4305	-	50	Külön rendelésre
90KO-KB207-00	56.8	1.4571	-	50	Külön rendelésre
90KO-KB208-00	66.8	1.4305	-	60	Külön rendelésre
90KO-KB209-00	66.8	1.4571	-	60	Külön rendelésre

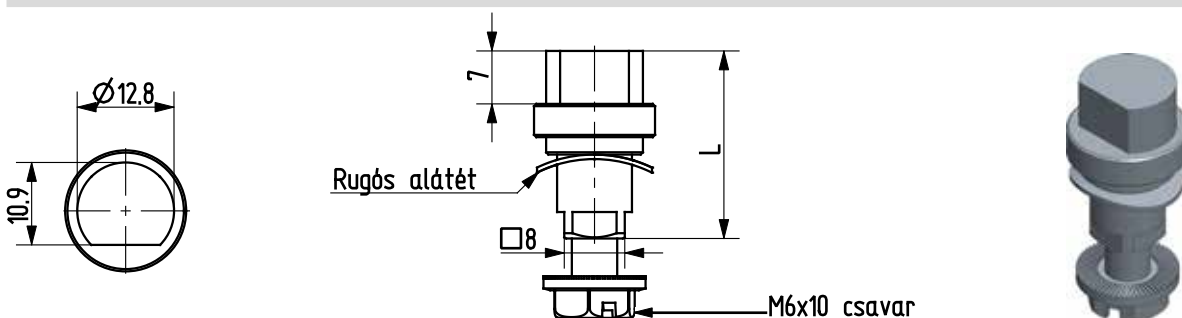

Termékszám	L (mm)	Alapanyag	Felületkezelés	Hozzá tartozó zárház beépítési mélysége (H) mm	Hozzárendelhető kulcs
90ZA-KB002-04	24.8	cinköntvény	krómozva	18	Külön rendelésre

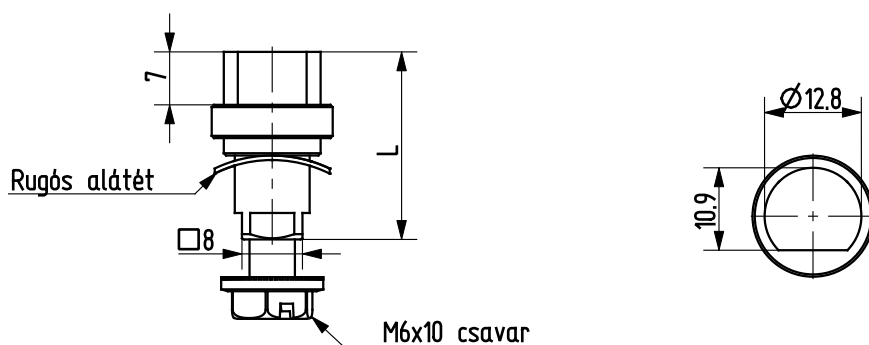

Termékszám	L (mm)	Alapanyag	Felületkezelés	Hozzá tartozó zárház beépítési mélysége (H) mm	Hozzárendelhető kulcs
90ZA-KB002-06	24.8	cinköntvény	fekete porszórt	18	Külön rendelésre

Vasúti norma

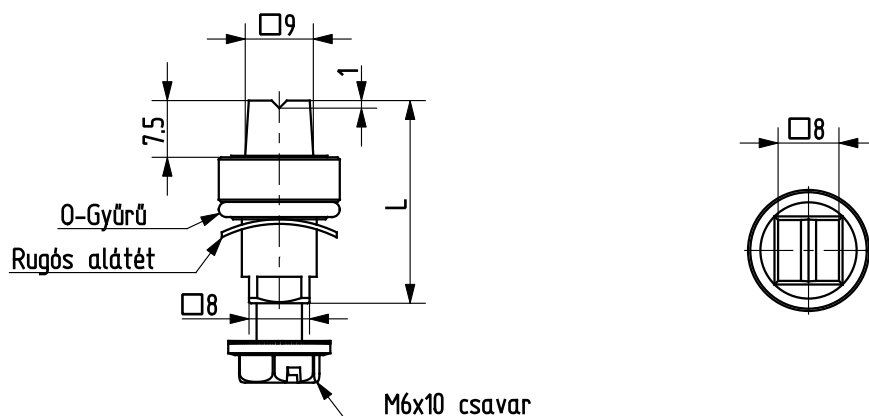

Termékszám	L (mm)	Alapanyag	Felületkezelés	Hozzá tartozó zárház beépítési mélysége (H) mm	Hozzárendelhető kulcs
90KO-KB222-00	26.8	1.4305	-	18	90ZA-ZK003-06
90KO-KB223-00	26.8	1.4571	-	18	90ZA-ZK003-06
90KO-KB224-00	38.8	1.4305	-	30	90ZA-ZK003-06
90KO-KB225-00	38.8	1.4571	-	30	90ZA-ZK003-06
90KO-KB226-00	44.8	1.4305	-	36	90ZA-ZK003-06
90KO-KB227-00	44.8	1.4571	-	36	90ZA-ZK003-06
90KO-KB228-00	48.8	1.4305	-	40	90ZA-ZK003-06
90KO-KB229-00	48.8	1.4571	-	40	90ZA-ZK003-06
90KO-KB230-00	58.8	1.4305	-	50	90ZA-ZK003-06
90KO-KB231-00	58.8	1.4571	-	50	90ZA-ZK003-06
90KO-KB052-00	68.8	1.4305	-	60	90ZA-ZK003-06
90KO-KB232-00	68.8	1.4571	-	60	90ZA-ZK003-06



Zárbetétek

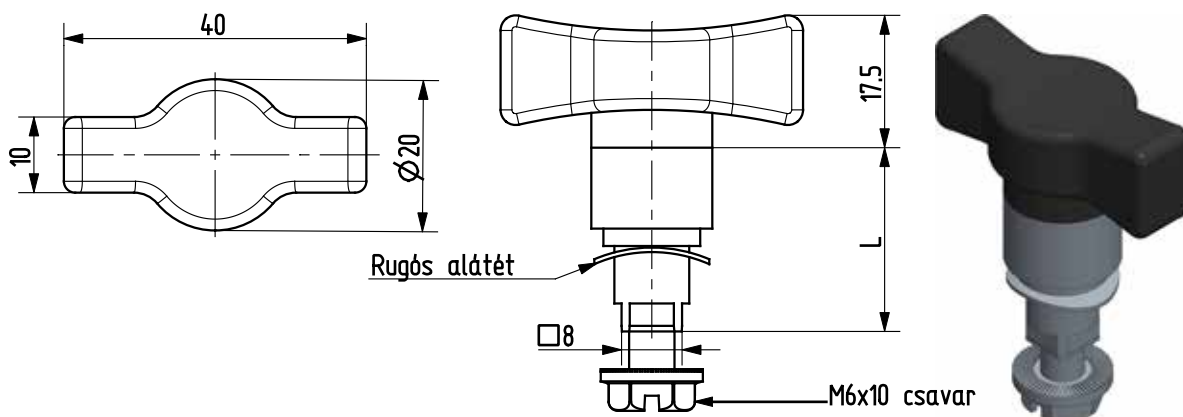

Termékszám	L (mm)	Alapanyag	Felületkezelés	Hozzá tartozó zárház beépítési mélysége (H) mm
90ZA-KB027-00	24.8	cinköntvény / PA	-	18

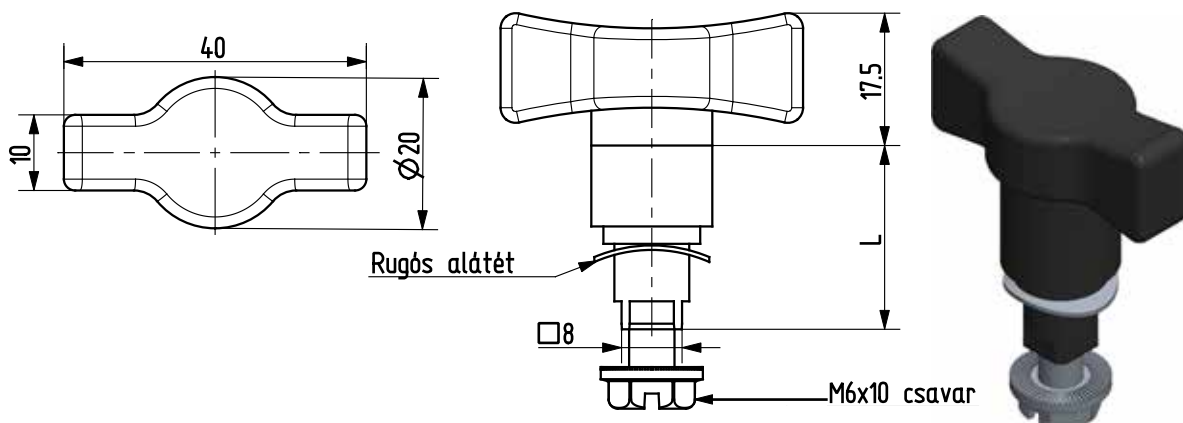

Termékszám	L (mm)	Alapanyag	Felületkezelés	Hozzá tartozó zárház beépítési mélysége (H) mm
90PA-KB025-00	24.8	PA	-	18

Megjegyzés:
*vevői logóval
rendelhető

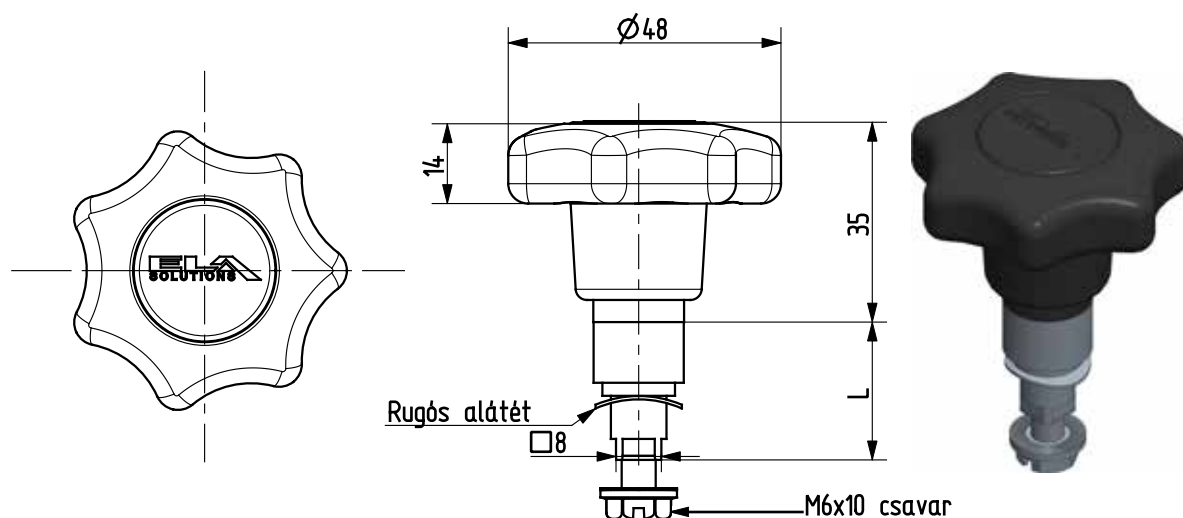

Termékszám	L (mm)	Alapanyag	Felületkezelés	Hozzá tartozó zárház beépítési mélysége (H) mm
90ZA-KB028-00	24.8	cinköntvény / PA	-	18

Zárbetétek

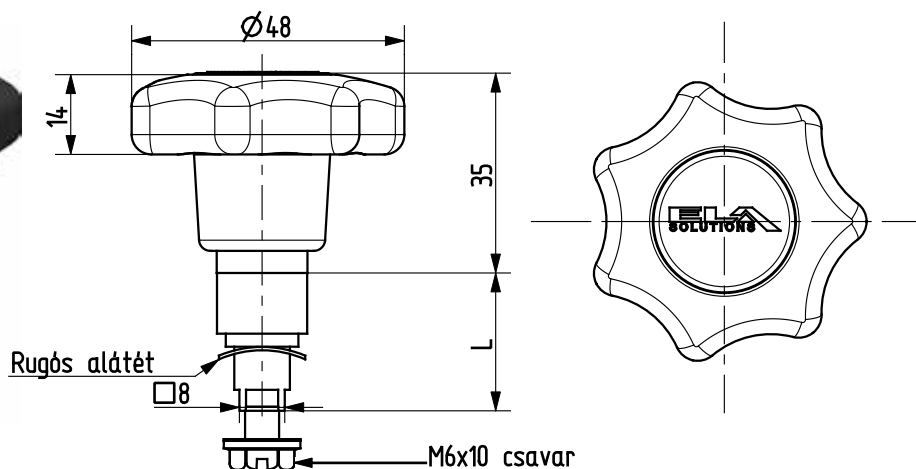

Megjegyzés:
*vevői logóval
rendelhető



Termékszám	L (mm)	Alapanyag	Felületkezelés	Hozzá tartozó zárház beépítési mélysége (H) mm
90PA-KB026-00*	24.8	PA	-	18

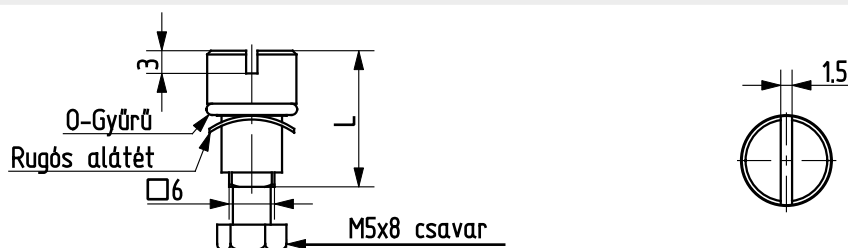

Termékszám	L (mm)	Alapanyag	Felületkezelés	Hozzá tartozó zárház beépítési mélysége (H) mm
90KO-KB038-00	18	1.4305	-	13.5
90KO-KB074-00	18	1.4571	-	13.5

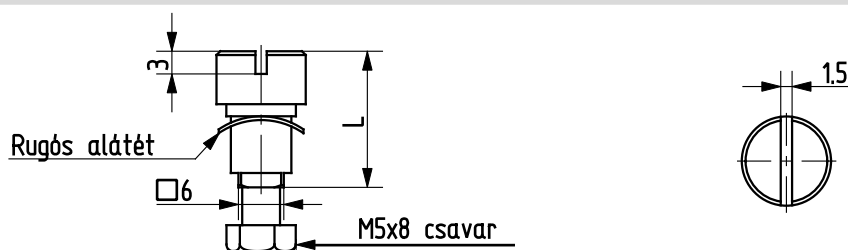

Termékszám	L (mm)	Alapanyag	Felületkezelés	Hozzá tartozó zárház beépítési mélysége (H) mm
90ZA-KB010-04	18	cinköntvény	krómozva	13.5

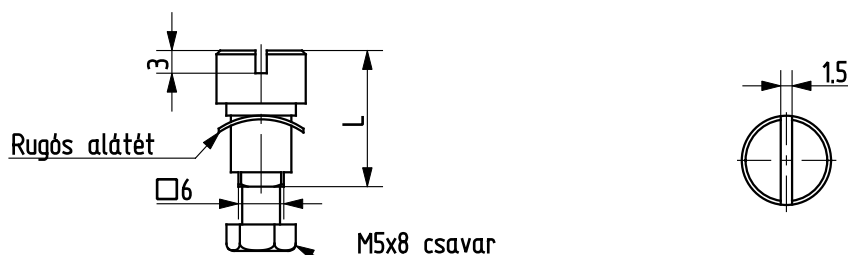

Termékszám	L (mm)	Alapanyag	Felületkezelés	Hozzá tartozó zárház beépítési mélysége (H) mm
90ZA-KB010-06	18	cinköntvény	fekete porszórt	13.5



Zárbetétek

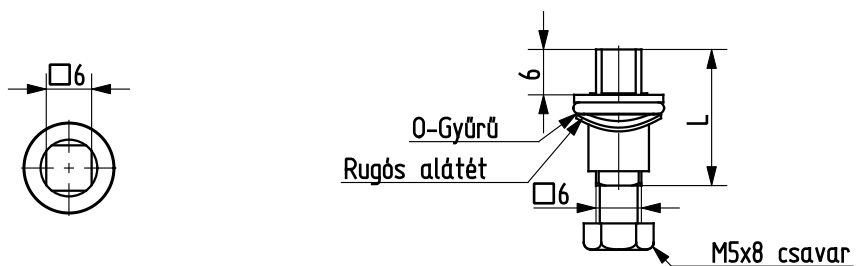

Termékszám	L (mm)	Alapanyag	Felületkezelés	Hozzá tartozó zárház beépítési mélysége (H) mm	Hozzárendelhető kulcs
90KO-KB075-00	18	1.4571	-	13.5	90ZA-ZK001-06
90KO-KB076-00	18	1.4305	-	13.5	90ZA-ZK001-06

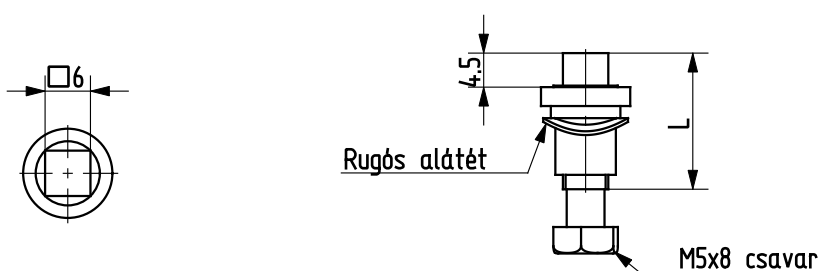

Termékszám	L (mm)	Alapanyag	Felületkezelés	Hozzá tartozó zárház beépítési mélysége (H) mm	Hozzárendelhető kulcs
90ZA-KB021-04	18	cinköntvény	krómozva	13.5	90ZA-ZK001-06

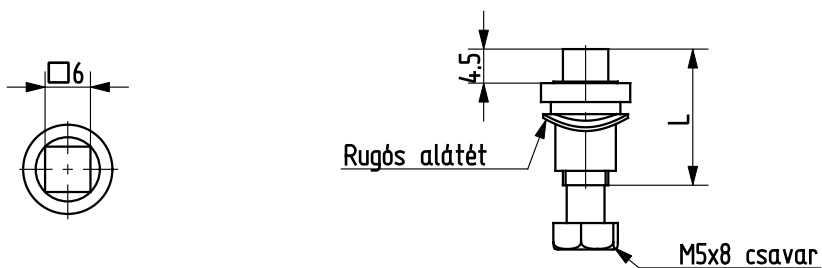

Termékszám	L (mm)	Alapanyag	Felületkezelés	Hozzá tartozó zárház beépítési mélysége (H) mm	Hozzárendelhető kulcs
90ZA-KB021-06	18	cinköntvény	fekete porszórt	13.5	90ZA-ZK001-06

Zárbetétek

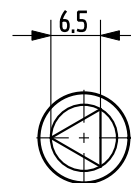
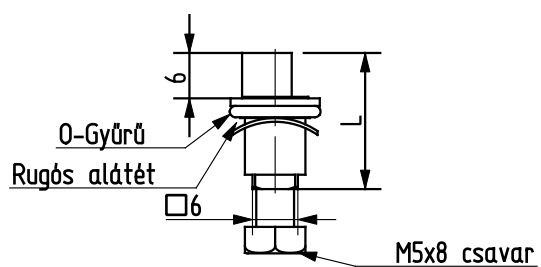

Termékszám	L (mm)	Alapanyag	Felületkezelés	Hozzá tartozó zárház beépítési mélysége (H) mm	Hozzárendelhető kulcs
90KO-KB077-00	18	1.4305	-	13.5	90ZA-ZK004-06
90KO-KB078-00	18	1.4571	-	13.5	90ZA-ZK004-06

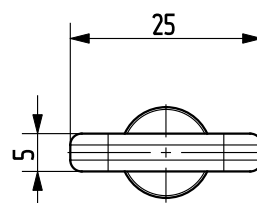
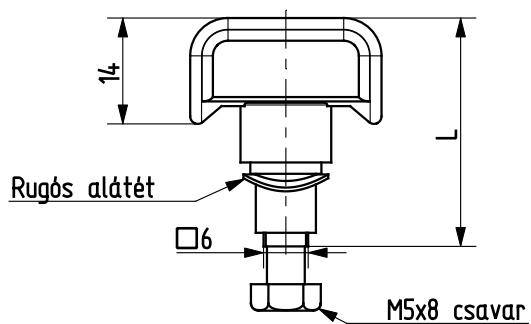

Termékszám	L (mm)	Alapanyag	Felületkezelés	Hozzá tartozó zárház beépítési mélysége (H) mm
90PA-KB024-00	30.2	PA	-	13.5



ZÁRNYELVEK

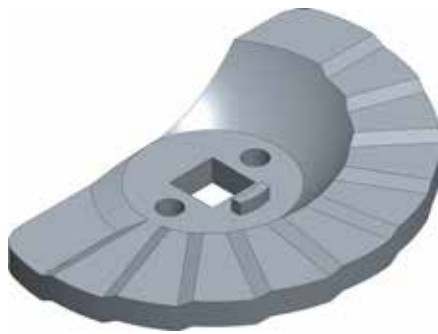

Zárnyelvek

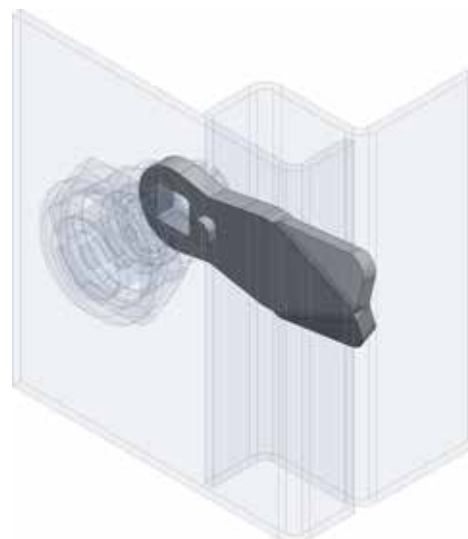
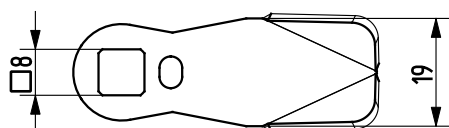
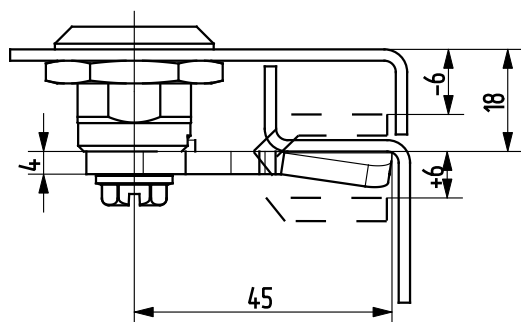

L=45 mm				
H (mm)	Rozsdamentes alapanyag (1.4301)	Felületkezelés	Acél alapanyag (ST)	Felületkezelés
-14	90KO-NY004-00	-	90ST-NY004-01	horganyozva
-12	90KO-NY006-00	-	90ST-NY006-01	horganyozva
-10	90KO-NY008-00	-	90ST-NY008-01	horganyozva
-8	90KO-NY010-00	-	90ST-NY010-01	horganyozva
-6	90KO-NY012-00	-	90ST-NY012-01	horganyozva
-5	90KO-NY013-00	-	90ST-NY013-01	horganyozva
-4	90KO-NY014-00	-	90ST-NY014-01	horganyozva
-2	90KO-NY016-00	-	90ST-NY016-01	horganyozva
0	90KO-NY018-00	-	90ST-NY018-01	horganyozva
+2	90KO-NY020-00	-	90ST-NY020-01	horganyozva
+4	90KO-NY022-00	-	90ST-NY022-01	horganyozva
+5	90KO-NY023-00	-	90ST-NY023-01	horganyozva
+6	90KO-NY024-00	-	90ST-NY024-01	horganyozva
+8	90KO-NY026-00	-	90ST-NY026-01	horganyozva
+10	90KO-NY028-00	-	90ST-NY028-01	horganyozva
+12	90KO-NY030-00	-	90ST-NY030-01	horganyozva
+14	90KO-NY032-00	-	90ST-NY032-01	horganyozva
+16	90KO-NY034-00	-	90ST-NY034-01	horganyozva
+18	90KO-NY036-00	-	90ST-NY036-01	horganyozva
+20	90KO-NY038-00	-	90ST-NY038-01	horganyozva
+22	90KO-NY040-00	-	90ST-NY040-01	horganyozva
+24	90KO-NY042-00	-	90ST-NY042-01	horganyozva
+26	90KO-NY044-00	-	90ST-NY044-01	horganyozva
+28	90KO-NY046-00	-	90ST-NY046-01	horganyozva
+29	90KO-NY047-00	-	90ST-NY047-01	horganyozva
+30	90KO-NY048-00	-	90ST-NY048-01	horganyozva
+32	90KO-NY050-00	-	90ST-NY050-01	horganyozva

Zárnyelvek

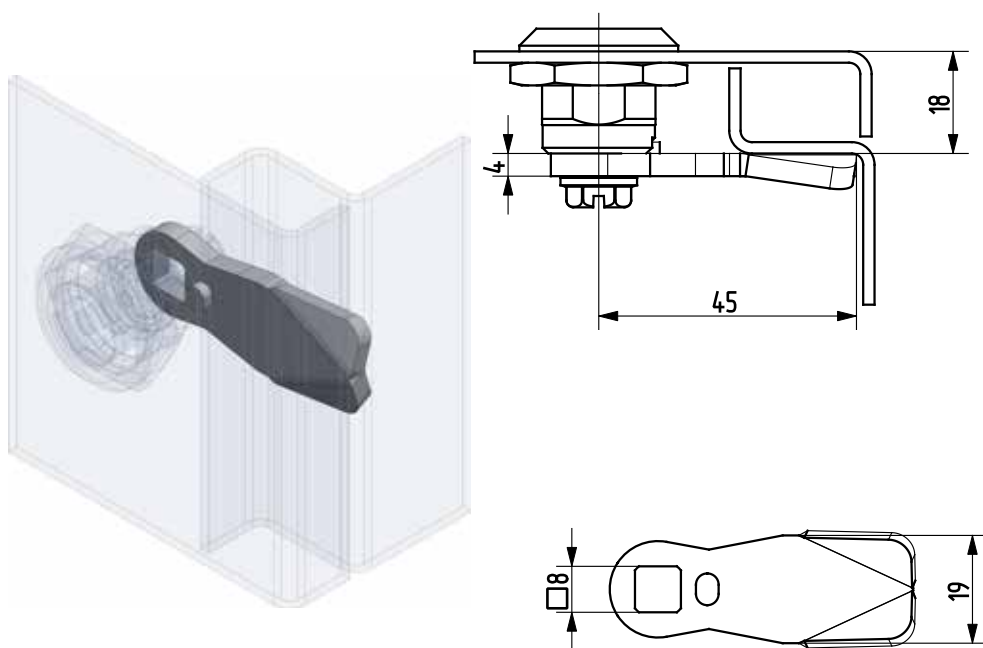

L=35 mm

H (mm)	Rozsdamentes alapanyag (1.4301)	Felületkezelés	Acél alapanyag (ST)	Felületkezelés
0	90KO-NY057-00	-	90ST-NY002-01	horganyozva
+2	90KO-NY051-00	-	90ST-NY051-01	horganyozva
+4	90KO-NY052-00	-	90ST-NY052-01	horganyozva
+6	90KO-NY053-00	-	90ST-NY053-01	horganyozva
+8	90KO-NY054-00	-	90ST-NY054-01	horganyozva
+10	90KO-NY055-00	-	90ST-NY055-01	horganyozva
+12	90KO-NY056-00	-	90ST-NY056-01	horganyozva

Zárnyelvek

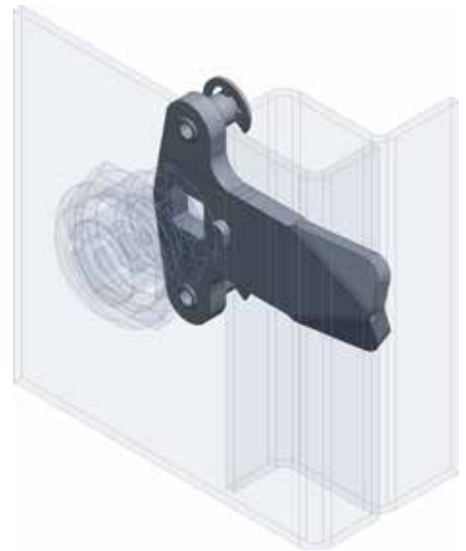
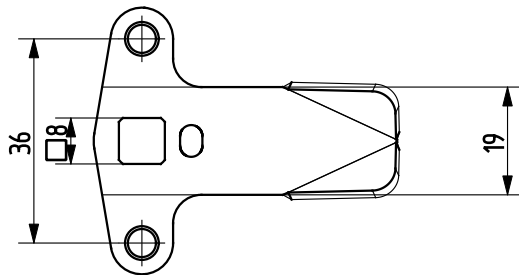
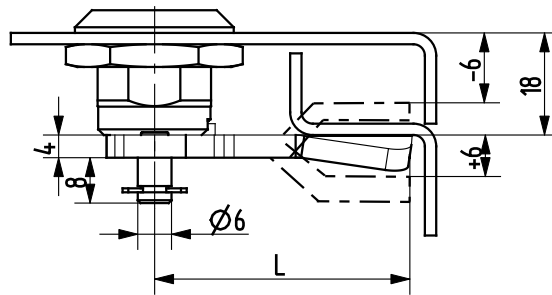

H (mm)	Rozsdamentes alapanyag (1.4301)	Felületkezelés	Acél alapanyag (ST)	Felületkezelés
-14	-	-	90ST-KNY004-01	horganyozva
-12	-	-	90ST-KNY006-01	horganyozva
-10	-	-	90ST-KNY008-01	horganyozva
-8	-	-	90ST-KNY010-01	horganyozva
-6	-	-	90ST-KNY012-01	horganyozva
-5	-	-	90ST-KNY013-01	horganyozva
-4	-	-	90ST-KNY014-01	horganyozva
-2	-	-	90ST-KNY016-01	horganyozva
0	90KO-KNY018-00	-	90ST-KNY018-01	horganyozva
+2	-	-	90ST-KNY020-01	horganyozva
+4	90KO-KNY022-00	-	90ST-KNY022-01	horganyozva
+6	-	-	90ST-KNY024-01	horganyozva
+8	90KO-KNY026-00	-	90ST-KNY026-01	horganyozva
+10	-	-	90ST-KNY028-01	horganyozva
+12	-	-	90ST-KNY030-01	horganyozva
+14	-	-	90ST-KNY032-01	horganyozva
+16	-	-	90ST-KNY034-01	horganyozva
+18	-	-	90ST-KNY036-01	horganyozva
+20	-	-	90ST-KNY038-01	horganyozva
+22	-	-	90ST-KNY040-01	horganyozva
+24	-	-	90ST-KNY042-01	horganyozva
+26	-	-	90ST-KNY044-01	horganyozva
+28	-	-	90ST-KNY046-01	horganyozva
+30	-	-	90ST-KNY048-01	horganyozva
+32	-	-	90ST-KNY050-01	horganyozva

Zárnyelvek

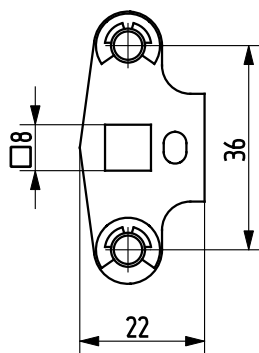
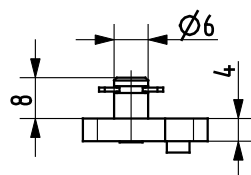

Termékszám	Alapanyag	Felületkezelés
90ST-KNY051-01	ST	horganyozva

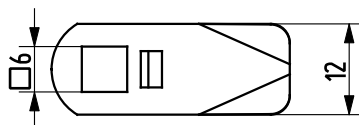
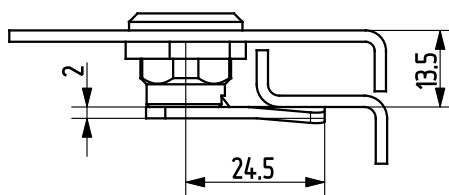

Termékszám	Alapanyag	Felületkezelés
90KO-NY003-00	1.4301	-
90KO-NY058-00	1.4571	-
90ST-NY003-01	ST	horganyozva



Zárnyelvek

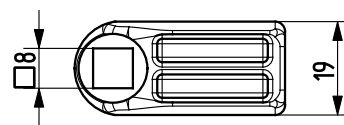
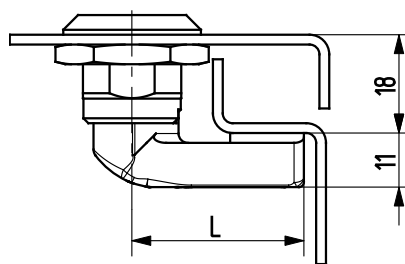

L=35 mm			
H (mm)	Termékszám	Alapanyag	Felületkezelés
0	90PA-NY018-00	poliamid	-
+2	90PA-NY020-00	poliamid	-
+6	90PA-NY024-00	poliamid	-

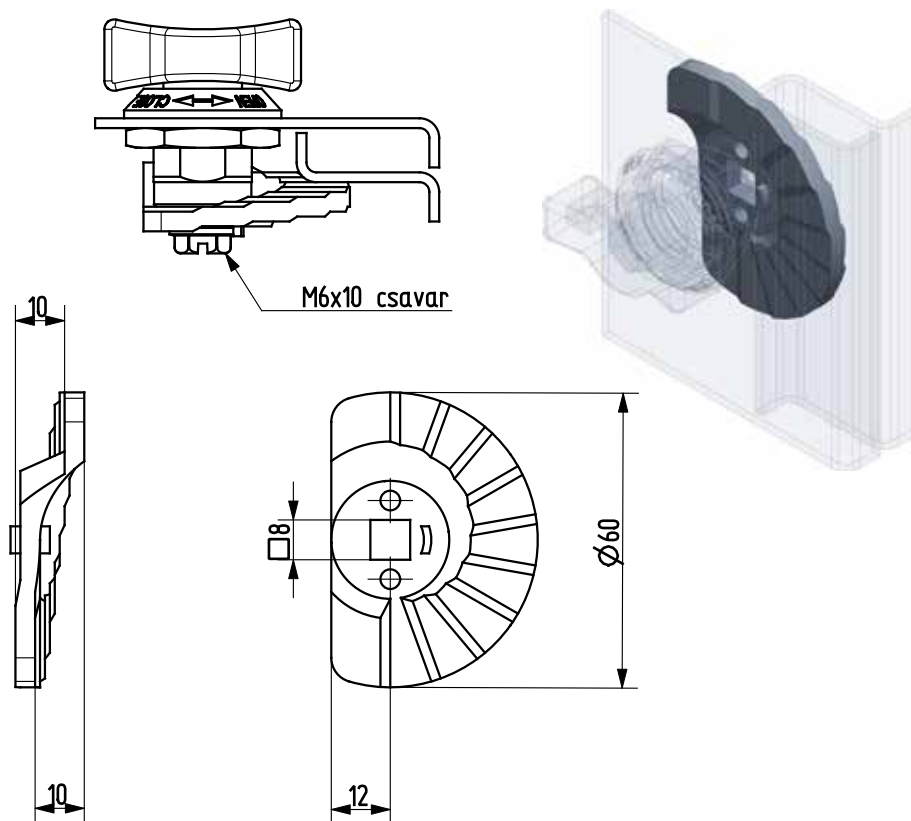

Termékszám	Alapanyag	Felületkezelés
90ZA-NY001-00	cinköntvény	-



ZSANÉROK

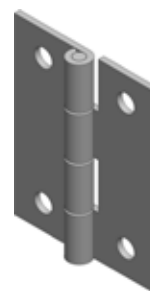
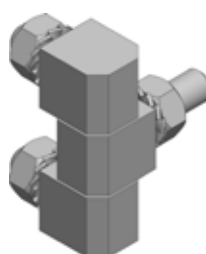
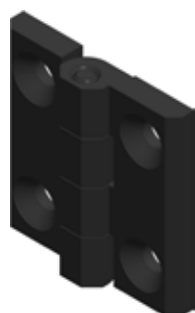
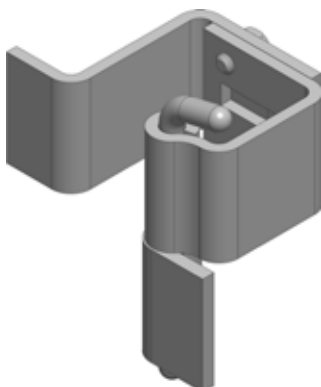
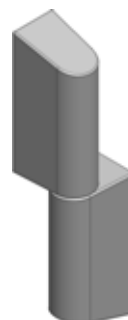

Zsanérok

Külső zsanérok

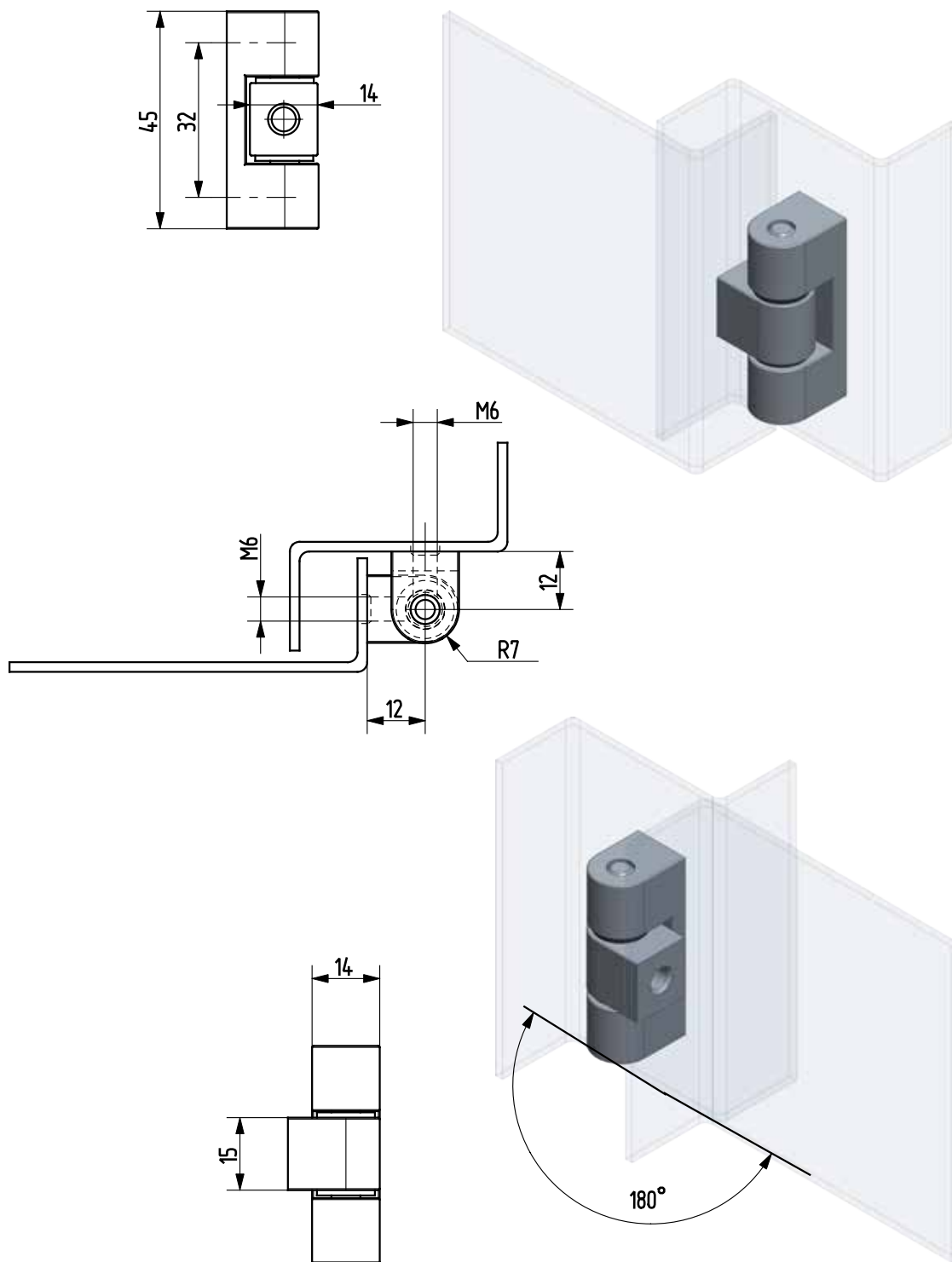

Termékszám	Alapanyag	Felületkezelés
90ZA-KZS008-04	cinköntvény	krómozva

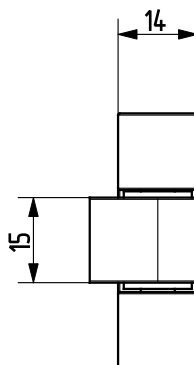
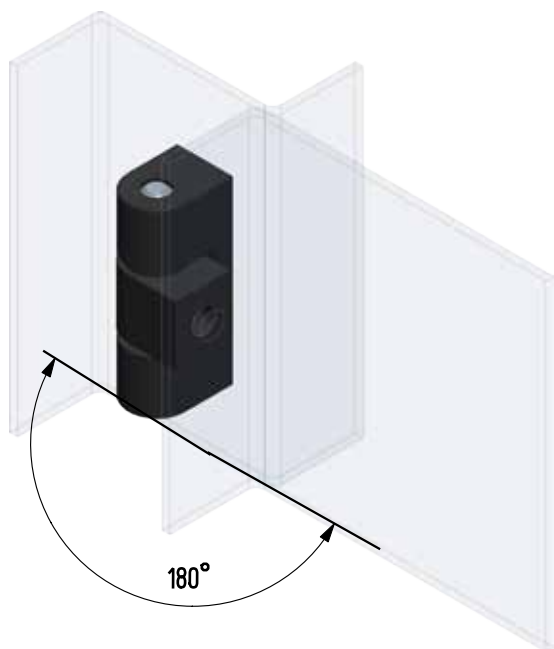
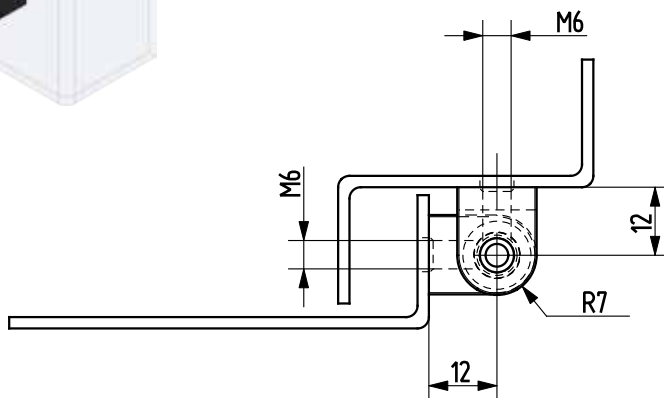
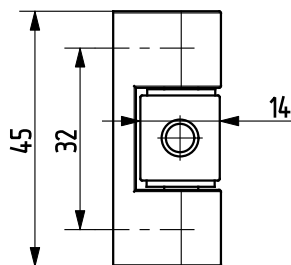
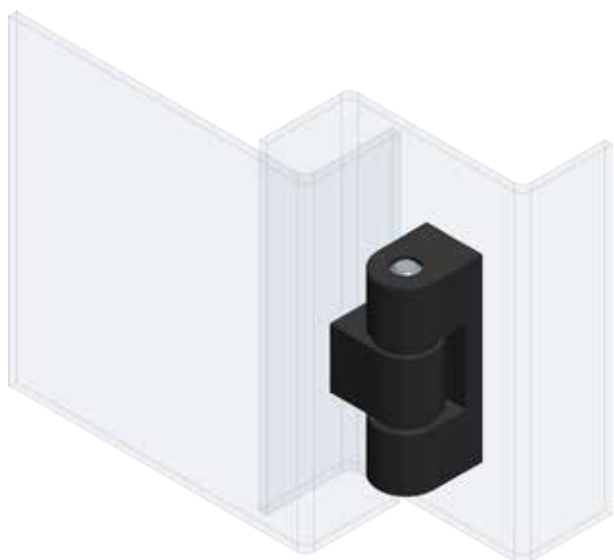

Termékszám	Alapanyag	Felületkezelés
90ZA-KZS008-06	cinköntvény	fekete porszórt

Zsanérok

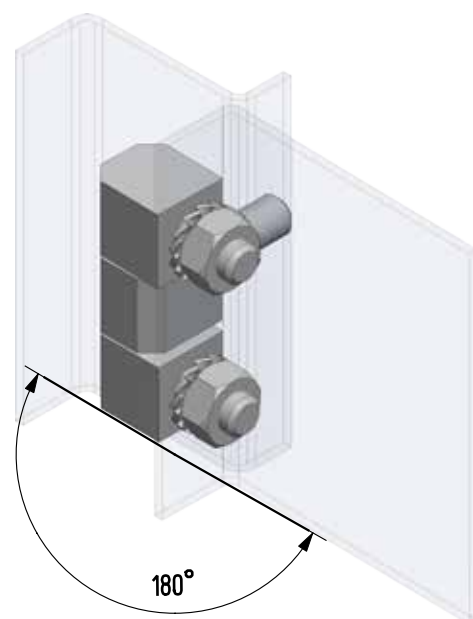
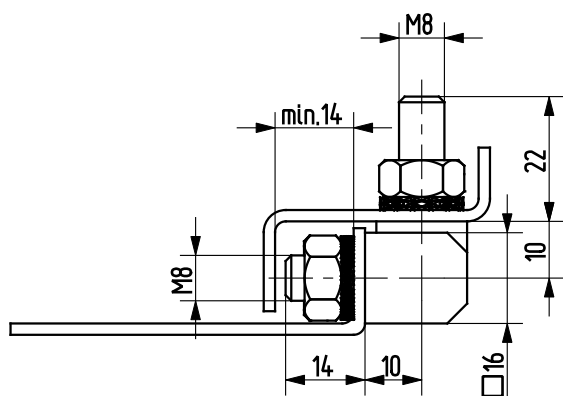
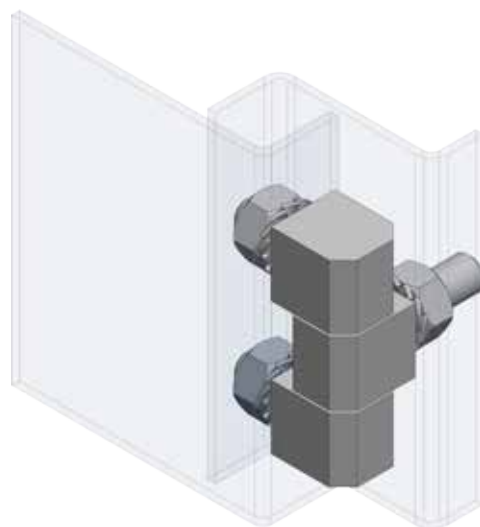
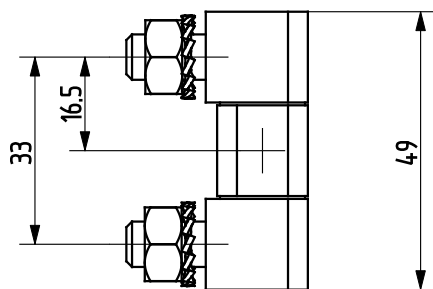

Termékszám	Alapanyag	Felületkezelés
90KO-KZS045-00	1.4305	-
90KO-KZS046-00	1.4571	-

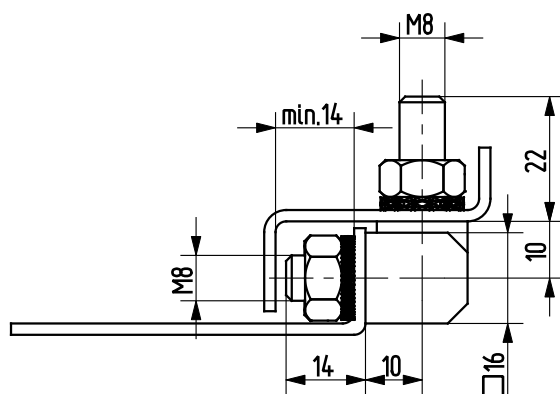
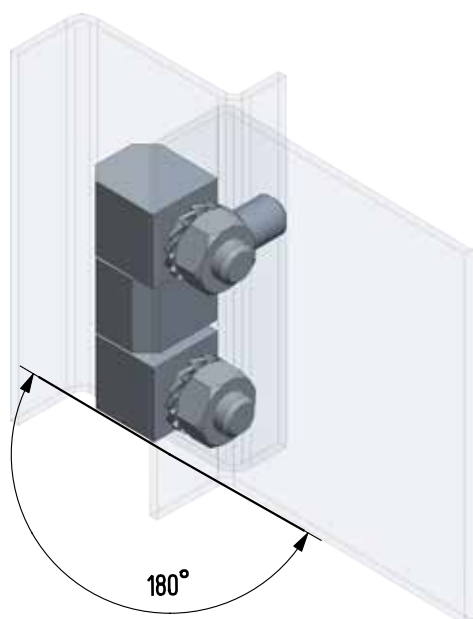
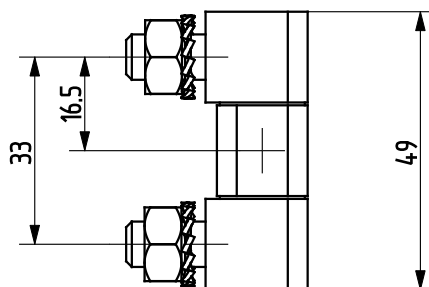
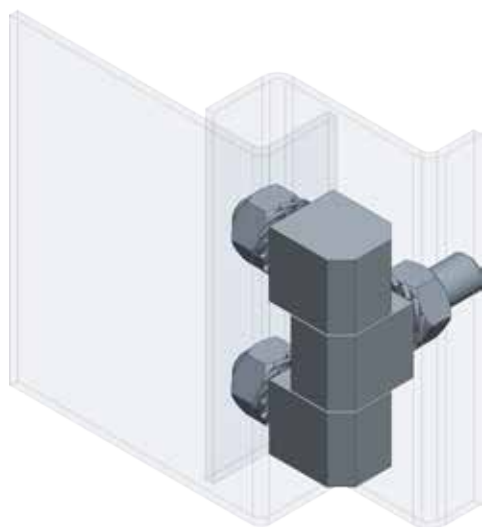

Termékszám	Alapanyag	Felületkezelés
90ST-KZS017-01	ST	horganyozva

Zsanérok

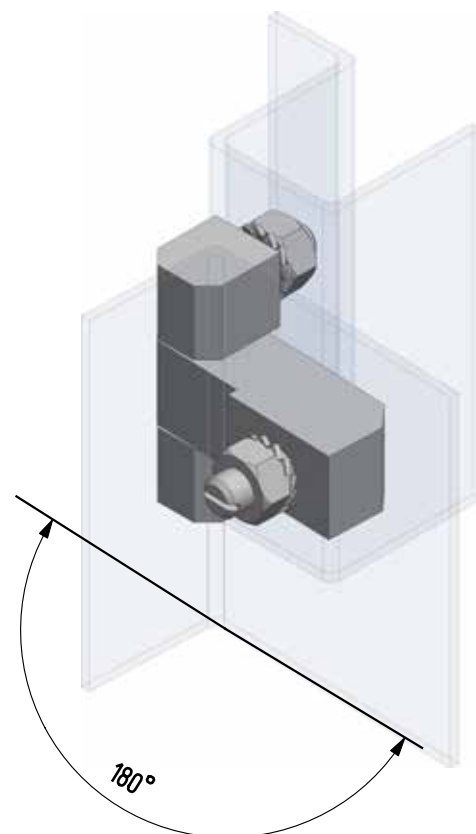
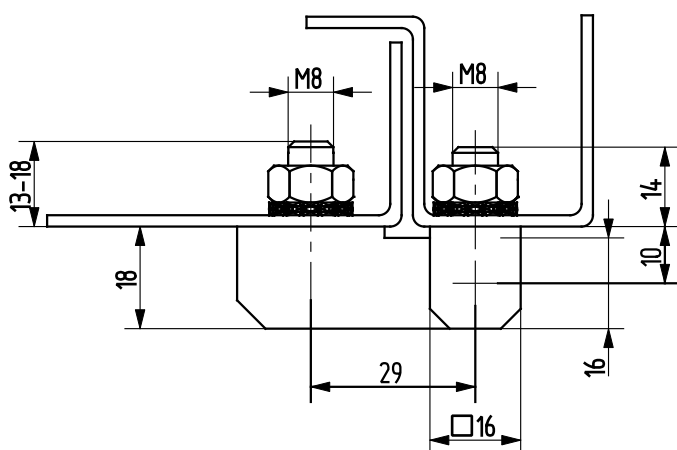
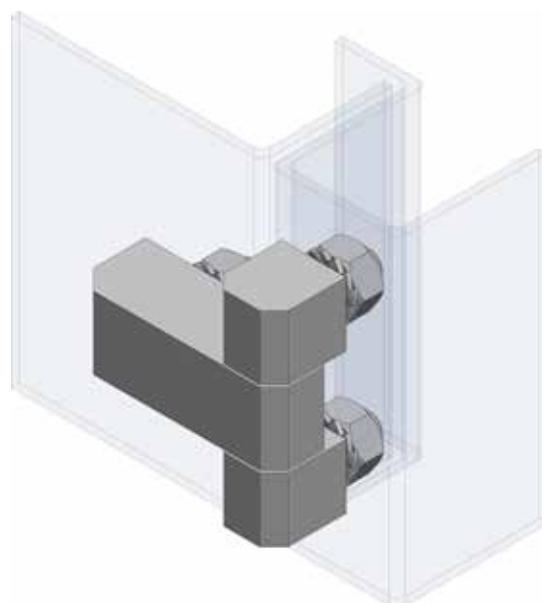
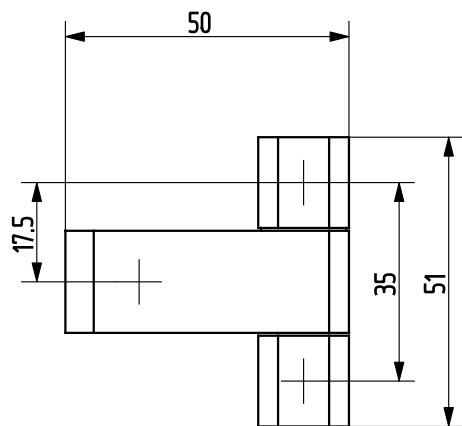

Termékszám	Alapanyag	Felületkezelés
90KO-KZS044-00	1.4305	-
90KO-KZS047-00	1.4571	-

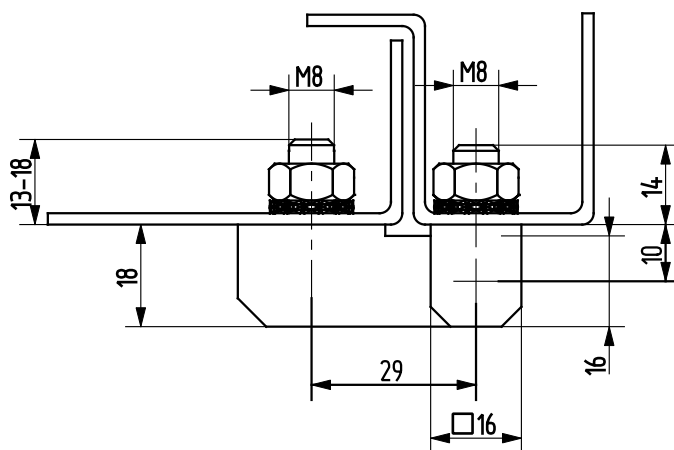
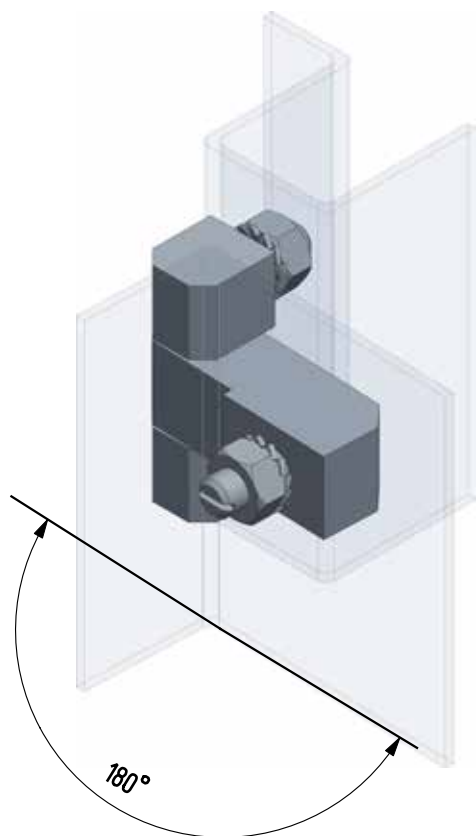
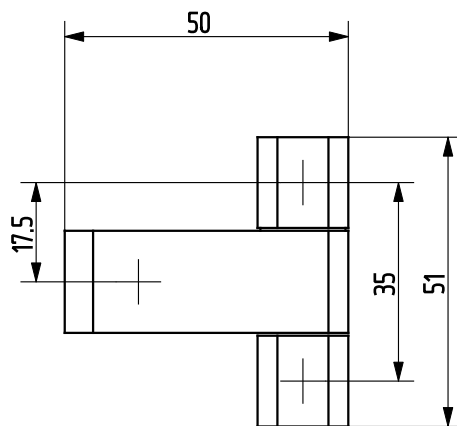
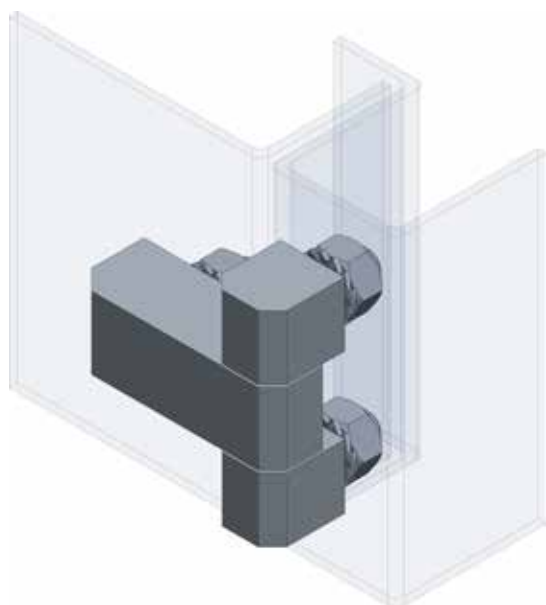

Termékszám	Alapanyag	Felületkezelés
90ST-KZS016-01	ST	horganyozva

Zsanérok

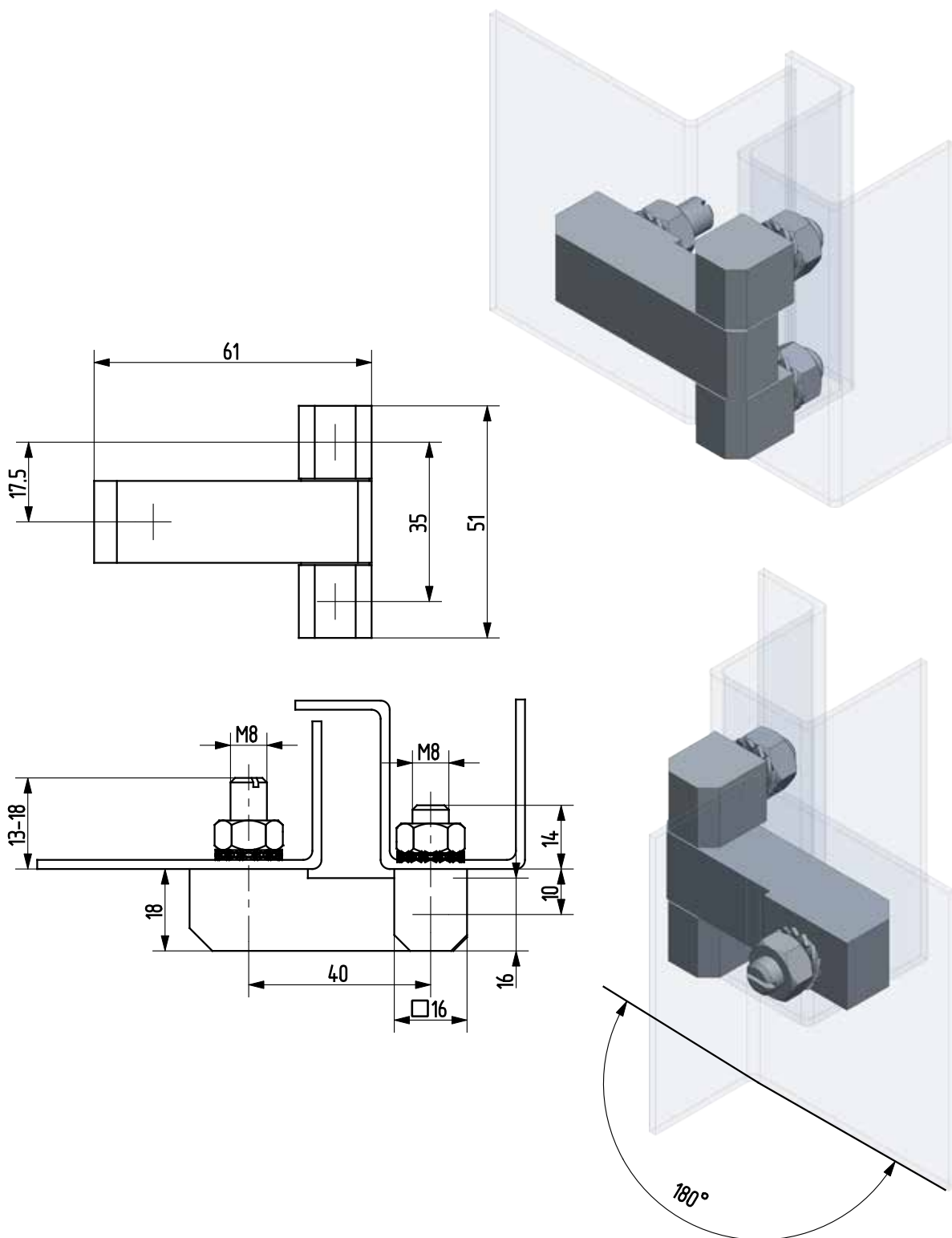

Termékszám	Alapanyag	Felületkezelés
90ST-KZS029-01	ST	horganyozva

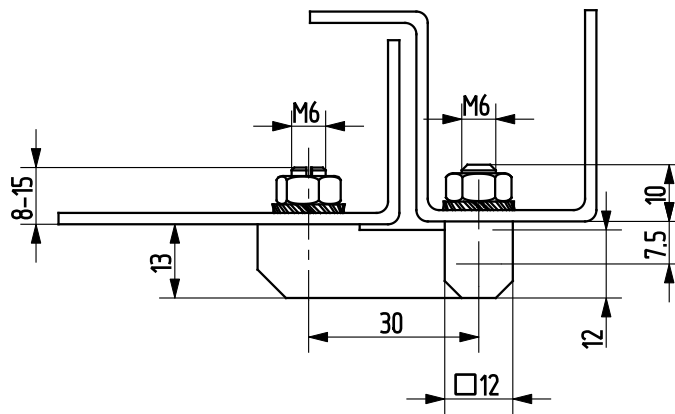
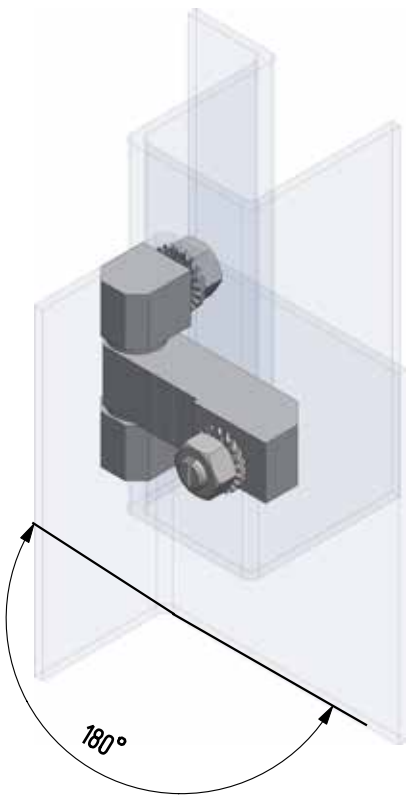
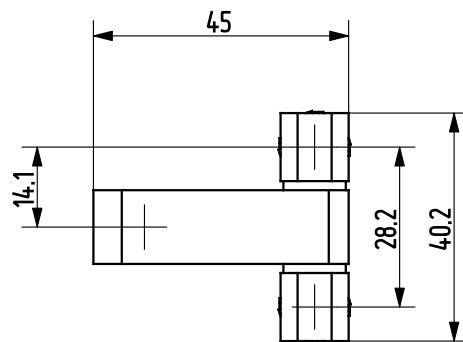
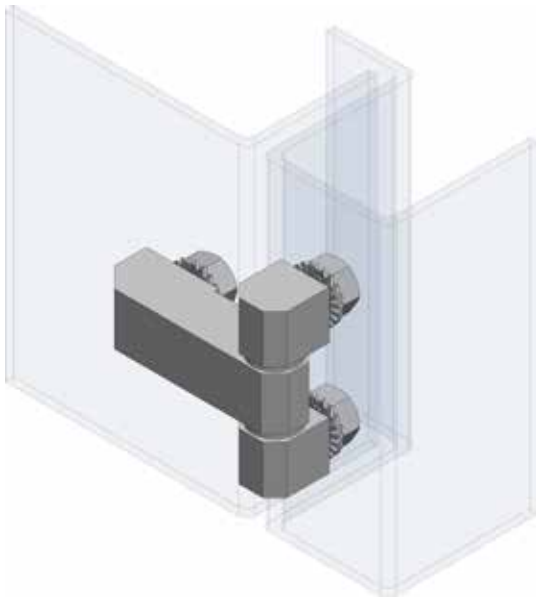

Termékszám	Alapanyag	Felületkezelés
90KO-KZS018-00	1.4305	-
90KO-KZS034-00	1.4571	-

Zsanérok

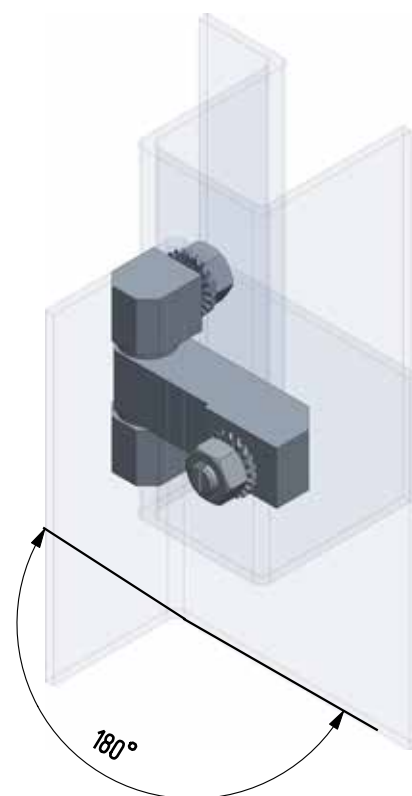
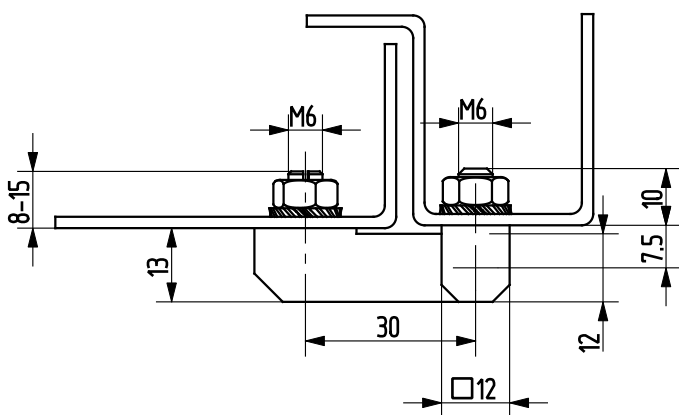
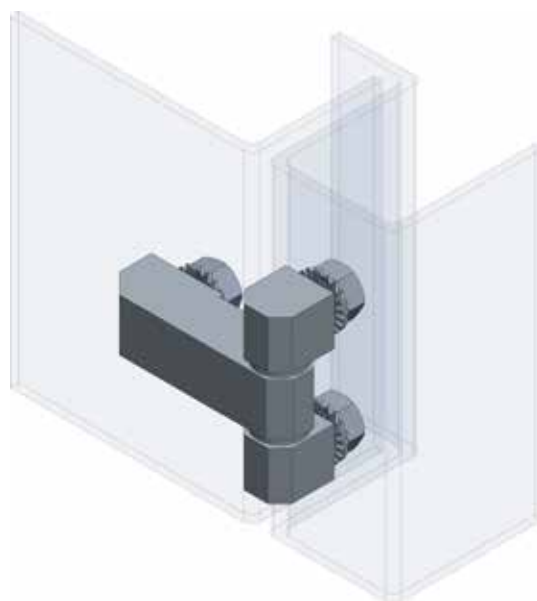
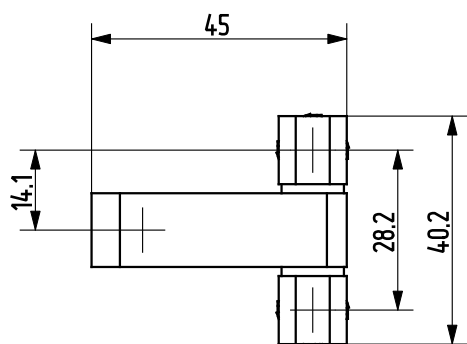

Termékszám	Alapanyag	Felületkezelés
90ST-KZS006-01	ST	horganyozva

Zsanérok

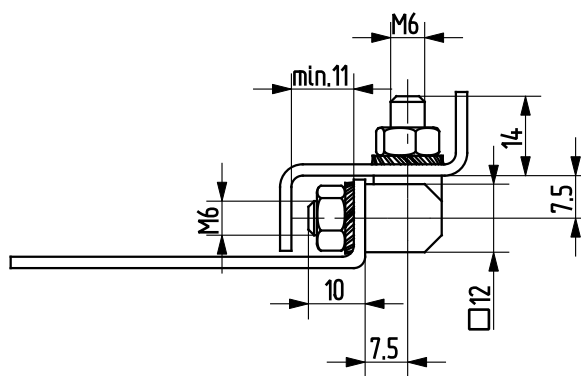
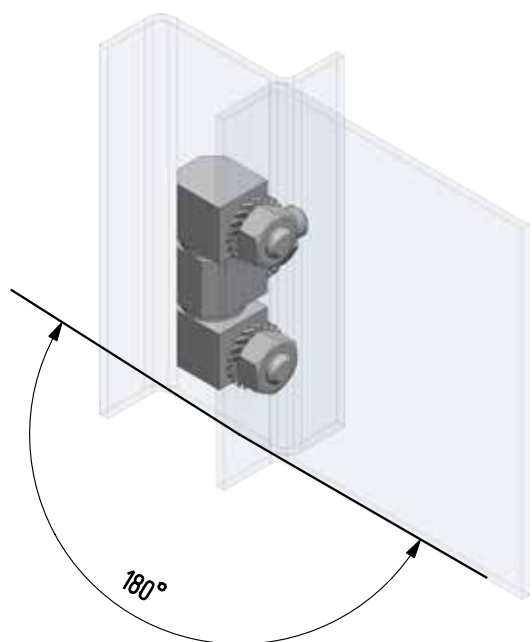
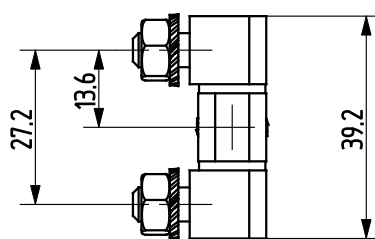
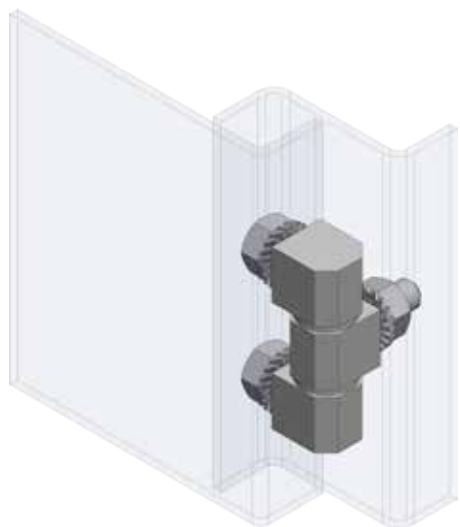

Termékszám	Alapanyag	Felületkezelés
90KO-KZS032-00	1.4305	-
90KO-KZS033-00	1.4571	-

Zsanérok

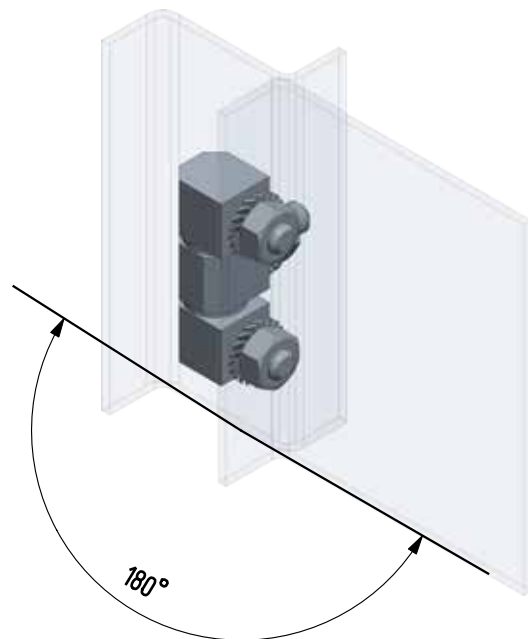
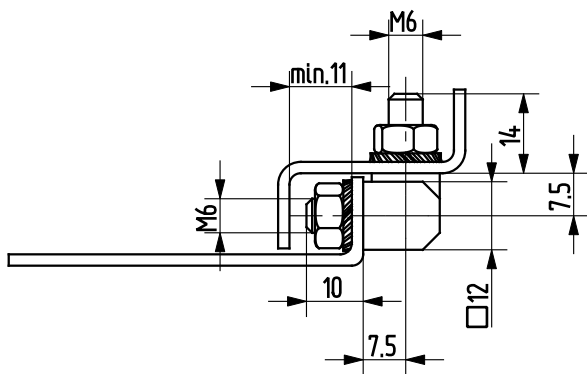
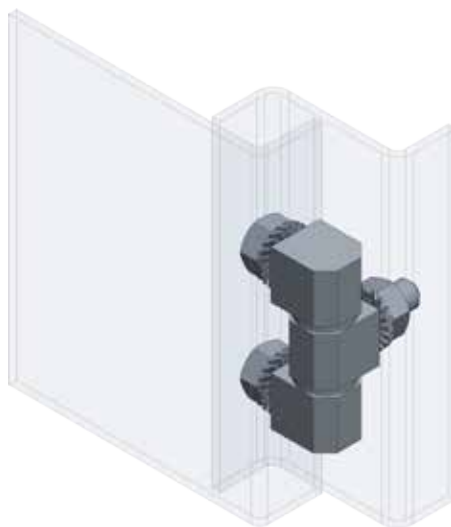
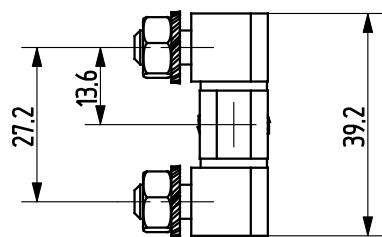

Termékszám	Alapanyag	Felületkezelés
90ST-KZS009-01	ST	horganyozva

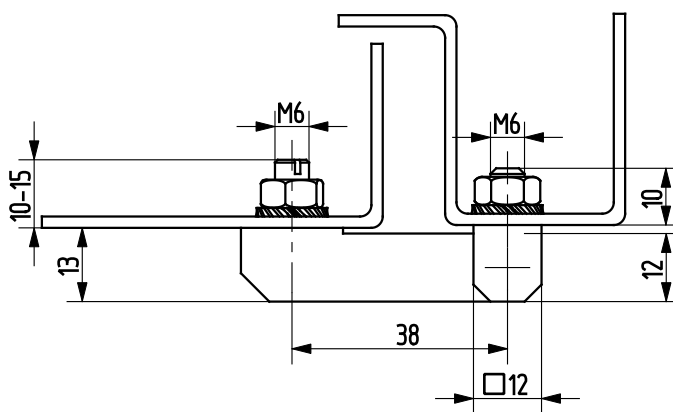
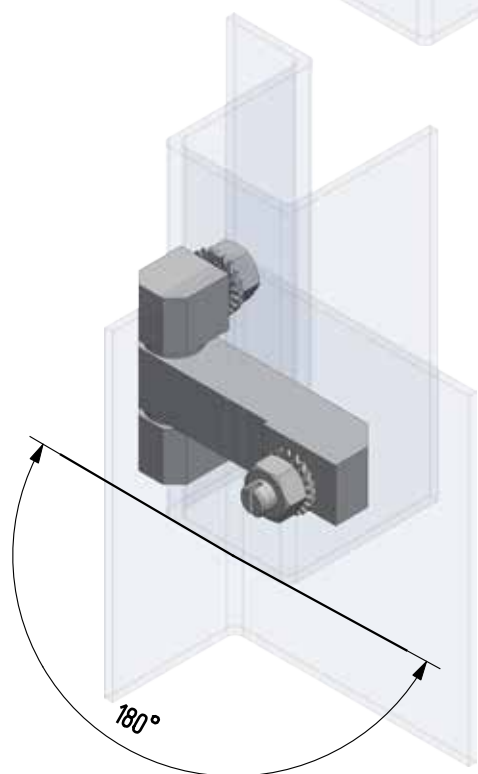
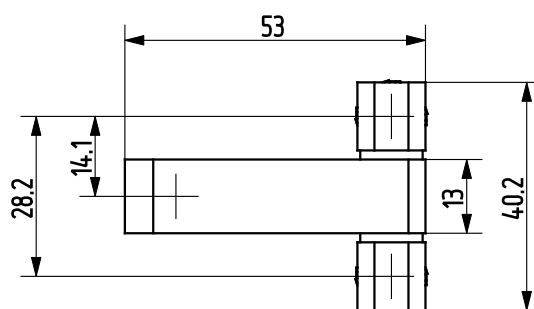
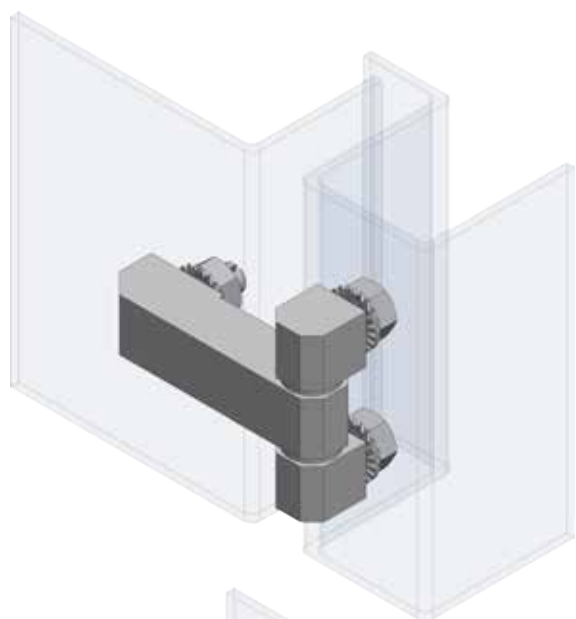

Termékszám	Alapanyag	Felületkezelés
90KO-KZS035-00	1.4305	-
90KO-KZS036-00	1.4571	-

Zsanérok

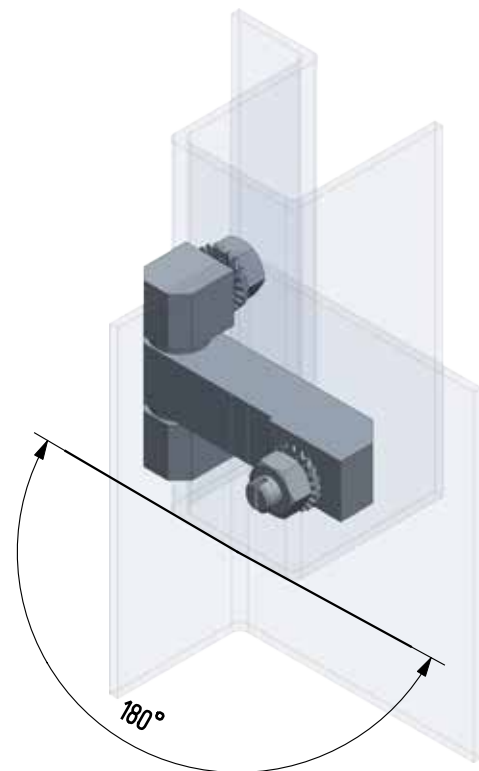
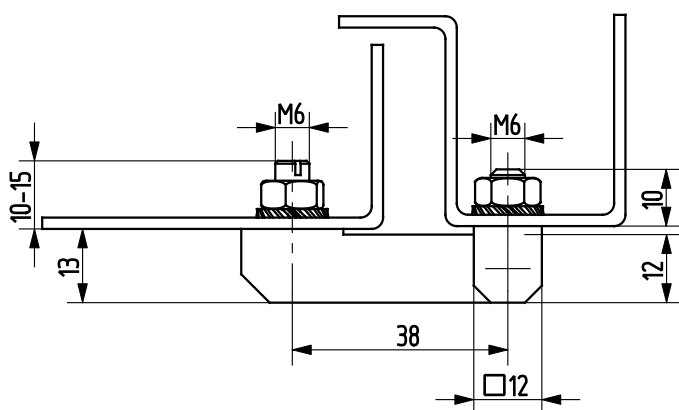
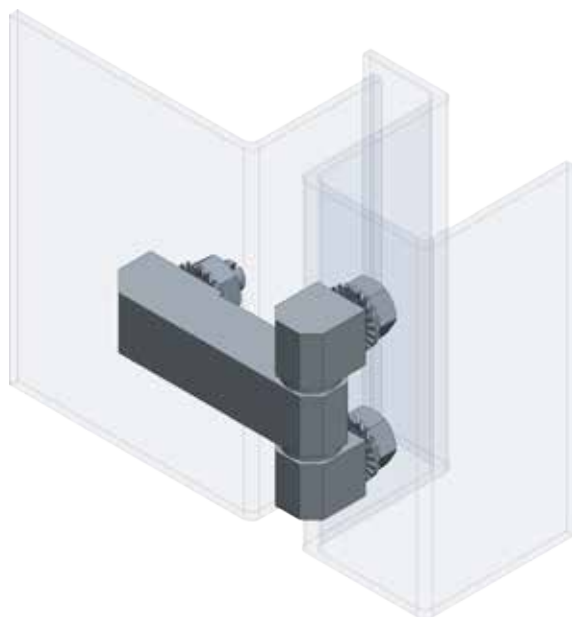
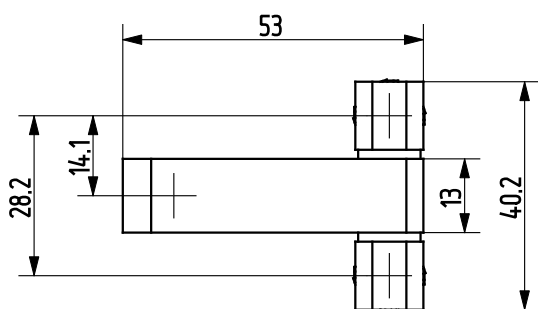

Termékszám	Alapanyag	Felületkezelés
90ST-KZS007-01	ST	horganyozva

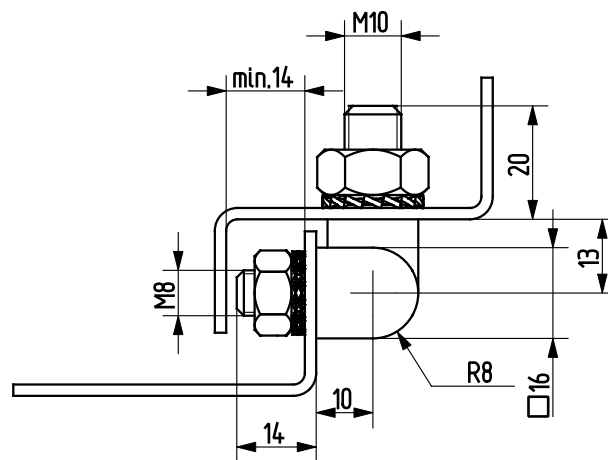
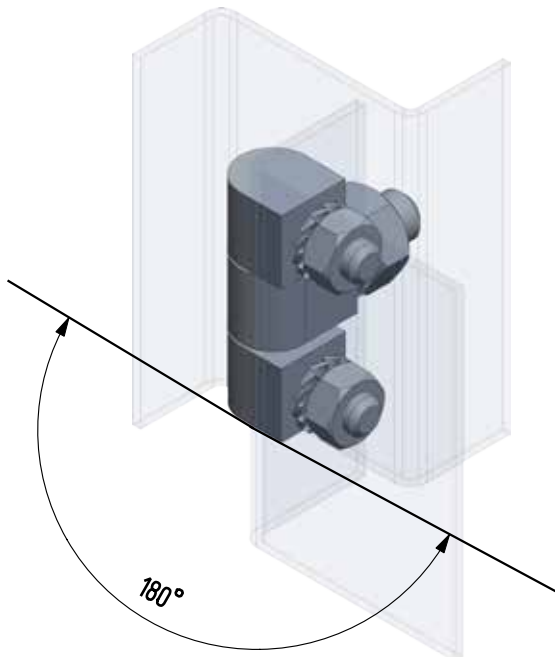
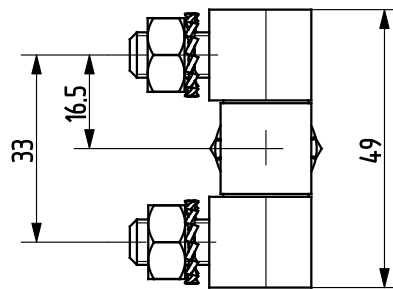
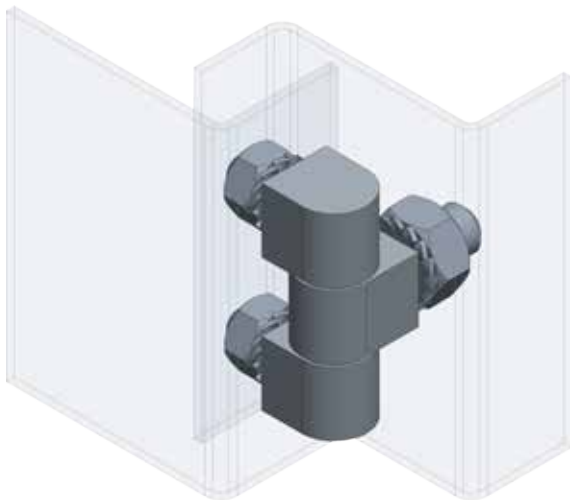

Termékszám	Alapanyag	Felületkezelés
90ST-KZS024-01	ST	horganyozva

Zsanérok

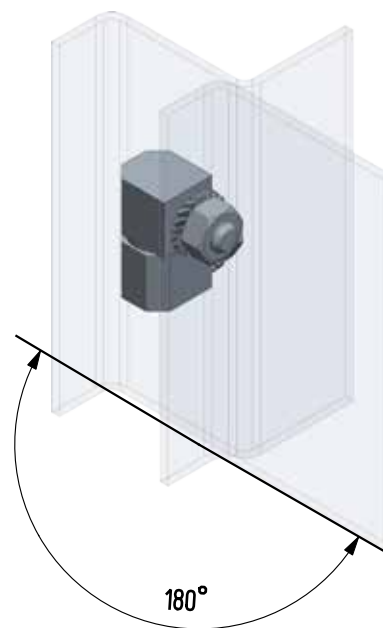
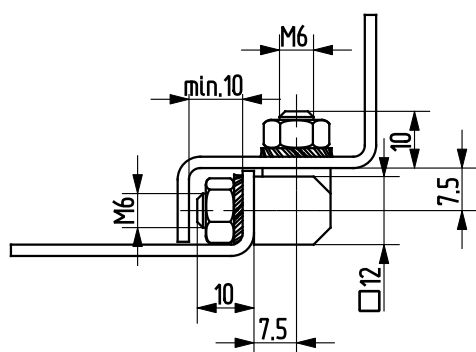
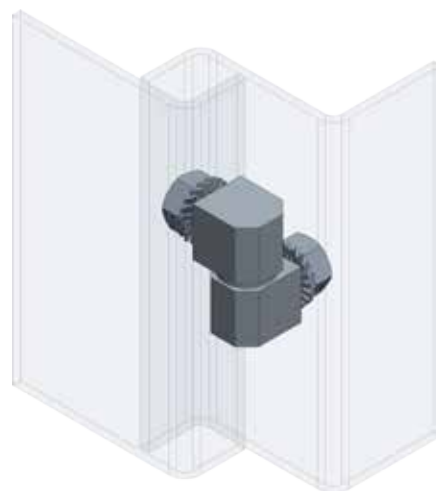
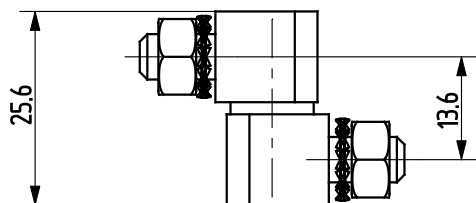

Termékszám	Alapanyag	Felületkezelés
90ST-KZS025-01	ST	horganyozva

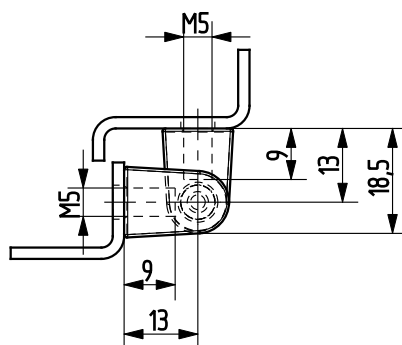
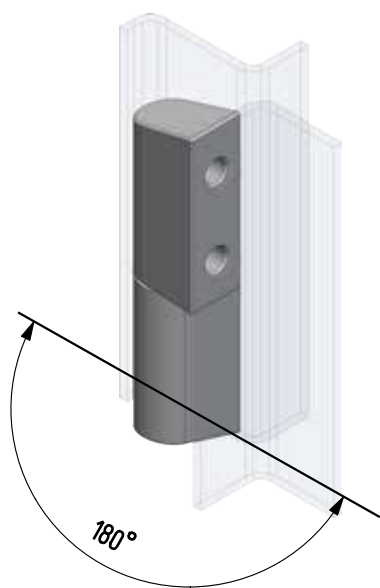
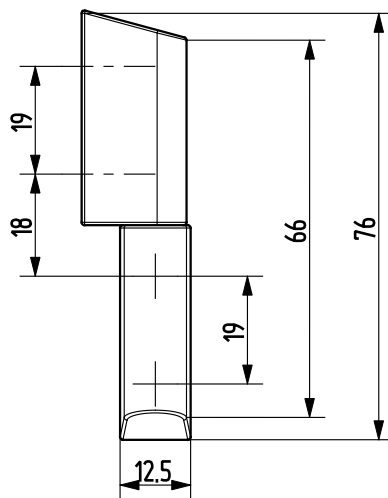
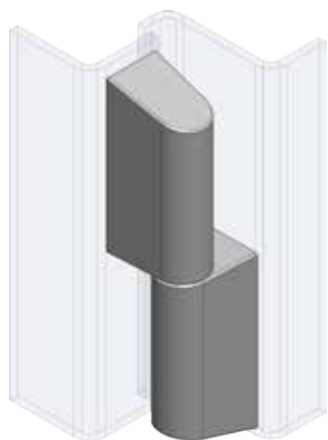

Termékszám	Alapanyag	Felületkezelés
90KO-KZS085-00	1.4571	-
90KO-KZS086-00	1.4305	-

Zsanérok

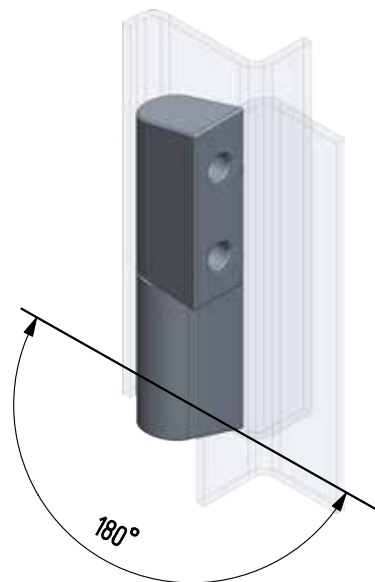
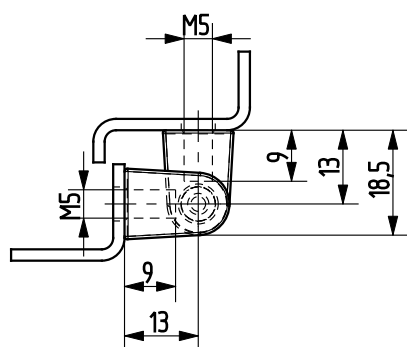
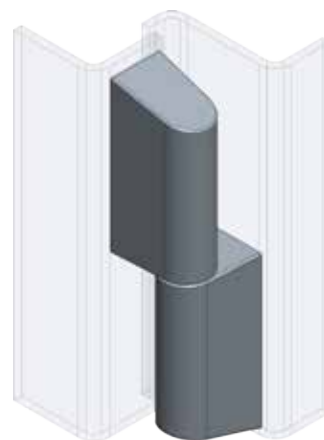
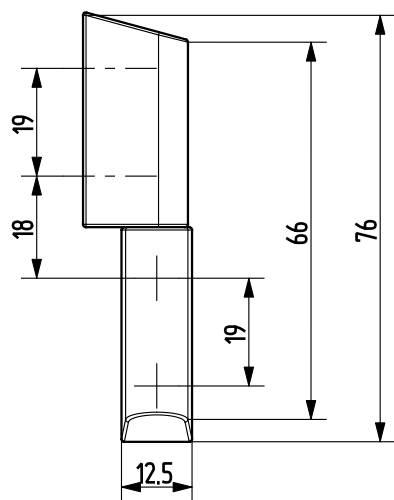

Termékszám	Alapanyag	Felületkezelés
90ST-KZS038-01	ST	horganyozva

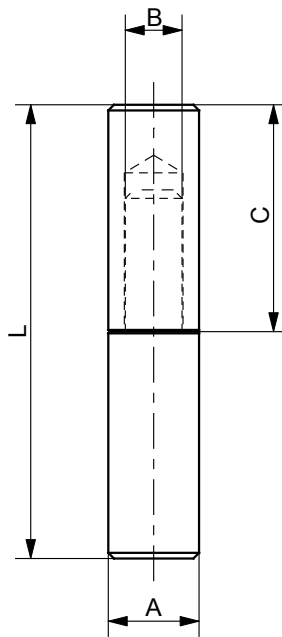

Termékszám	Alapanyag	L (mm)	A (D=mm)	B (D=mm)	C (mm)	Felületkezelés
90KO-KZS019-00	1.4305	40	8	5	20	-
90KO-KZS048-00	1.4571	40	8	5	20	-
90KO-KZS020-00	1.4305	50	10	6	25	-
90KO-KZS006-00	1.4571	50	10	6	25	-
90KO-KZS014-00	1.4305	60	12	8	30	-
90KO-KZS049-00	1.4571	60	12	8	30	-
90KO-KZS007-00	1.4305	70	13	8	35	-
90KO-KZS011-00	1.4571	70	13	8	35	-
90KO-KZS021-00	1.4305	80	16	10	40	-
90KO-KZS022-00	1.4571	80	16	10	40	-

Zsanérok

Rejtett zsanérok

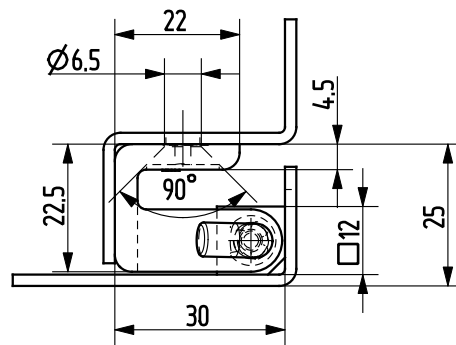
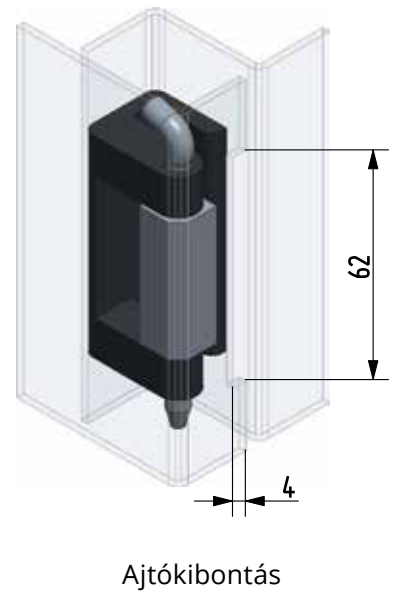
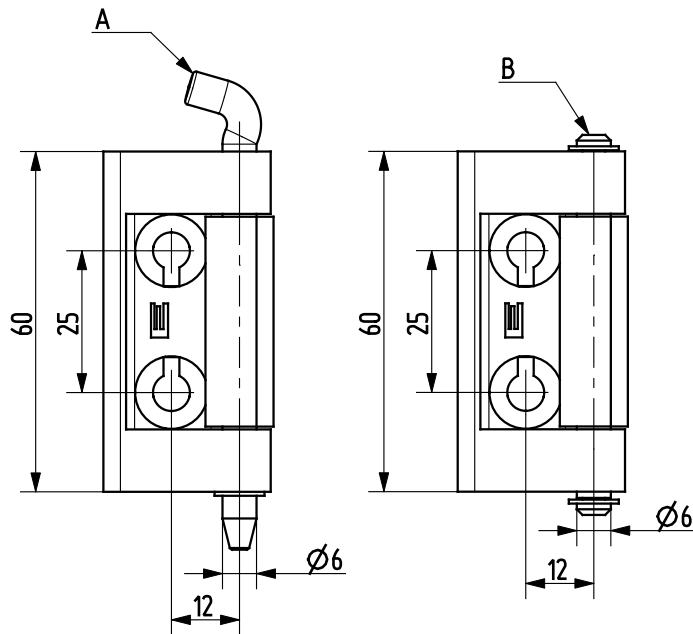

Megjegyzés:
*biztosító gyűrű
külön rendelésre!

Termékszám	Alapanyag	Felületkezelés	Belső rész	Csap verzió
90ZA-KZS006-06	cinköntvény	fekete porszórt	ST	B
90ZA-KZS012-06*	cinköntvény	fekete porszórt	ST	A
90ZA-KZS023-06*	cinköntvény	fekete porszórt	alumínium	A
90ZA-KZS024-06	cinköntvény	fekete porszórt	alumínium	B

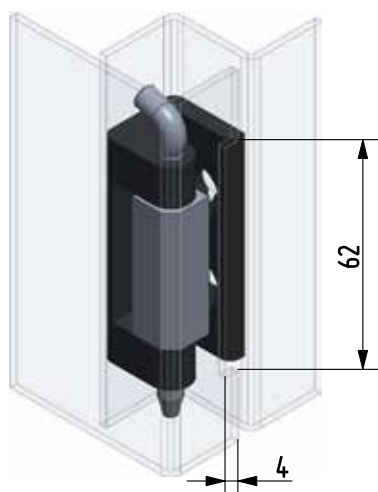

Ajtókibontás

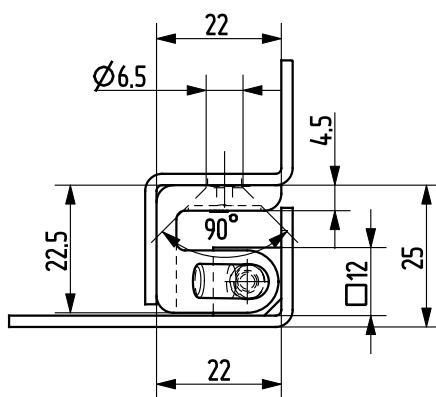
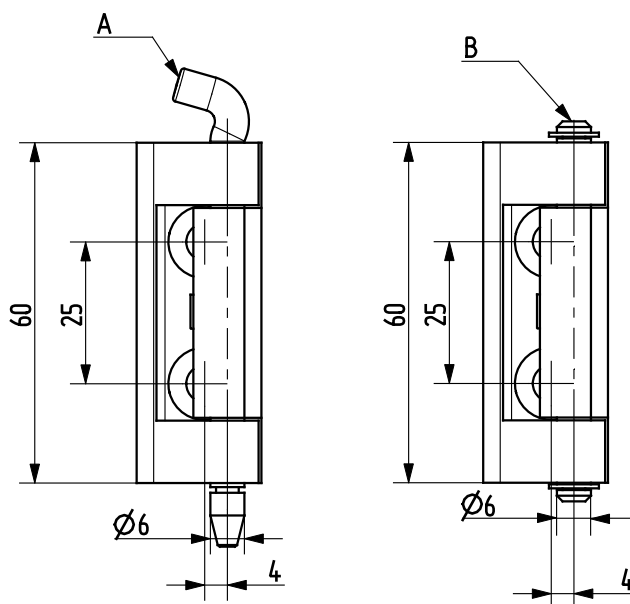

Termékszám	Alapanyag	Felületkezelés	Belső rész	Csap verzió
90ZA-KZS009-06*	cinköntvény	fekete porszórt	ST	A
90ZA-KZS003-06	cinköntvény	fekete porszórt	ST	B
90ZA-KZS018-06*	cinköntvény	fekete porszórt	alumínium	A
90ZA-KZS017-06	cinköntvény	fekete porszórt	alumínium	B

Megjegyzés:
*biztosító gyűű
külön rendelésre!

Zsanérok

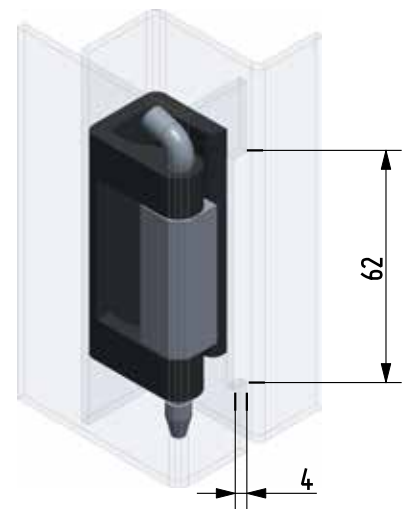
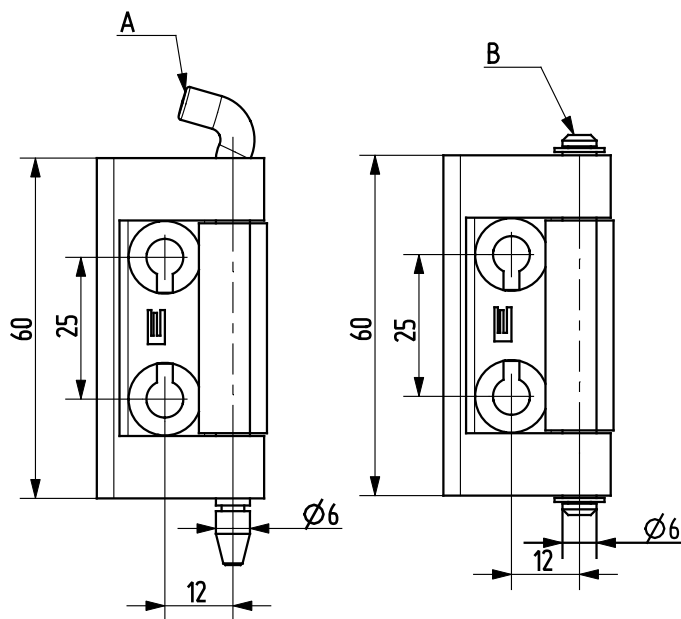

Ajtókibontás

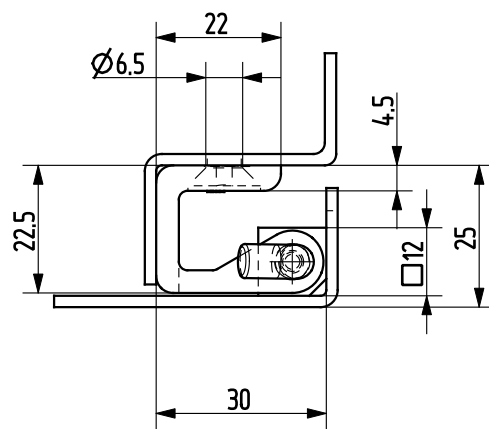

Megjegyzés:
*biztosító gyűrű
külön rendelésre!

Termékszám	Alapanyag	Felületkezelés	Belső rész	Csap verzió
90ZA-KZS007-06*	cinköntvény	fekete porszórt	ST	A
90ZA-KZS005-06	cinköntvény	fekete porszórt	ST	B
90ZA-KZS021-06*	cinköntvény	fekete porszórt	alumínium	A
90ZA-KZS022-06	cinköntvény	fekete porszórt	alumínium	B

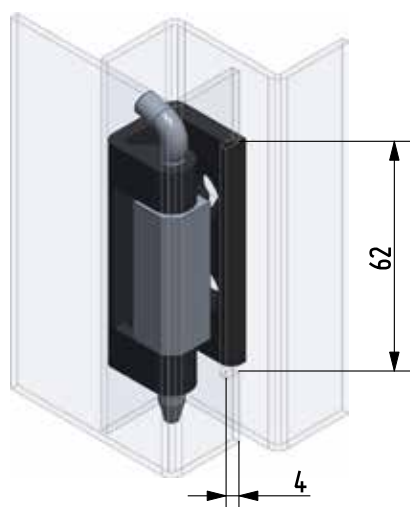

Ajtókibontás

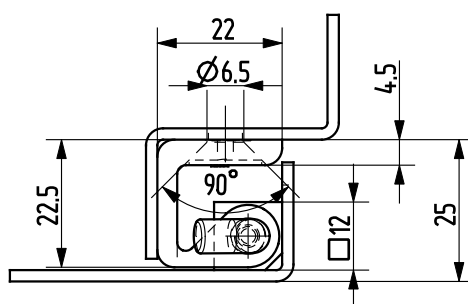
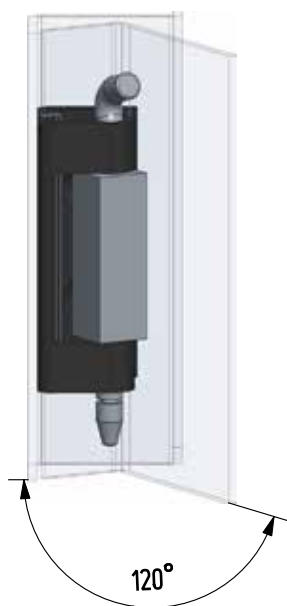
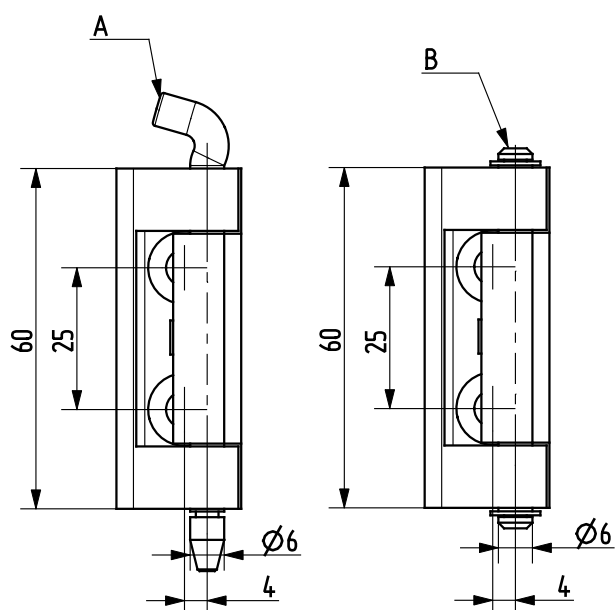

Termékszám	Alapanyag	Felületkezelés	Belső rész	Csap verzió
90ZA-KZS011-06*	cinköntvény	fekete porszórt	ST	A
90ZA-KZS004-06	cinköntvény	fekete porszórt	ST	B
90ZA-KZS020-06*	cinköntvény	fekete porszórt	alumínium	A
90ZA-KZS019-06	cinköntvény	fekete porszórt	alumínium	B

Megjegyzés:
*biztosító gyűű
külön rendelésre!

Zsanérok

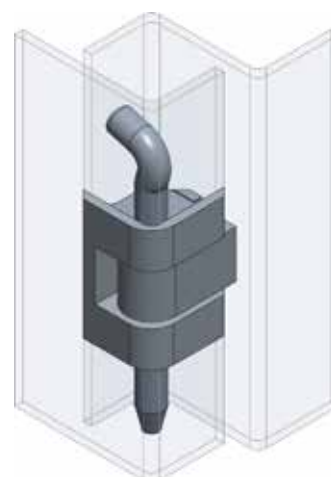
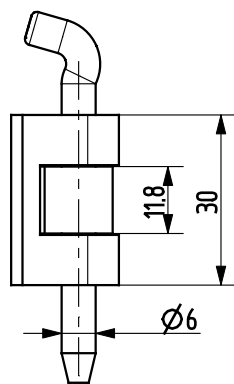
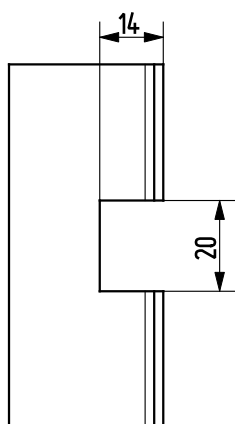

Ajtókibontás

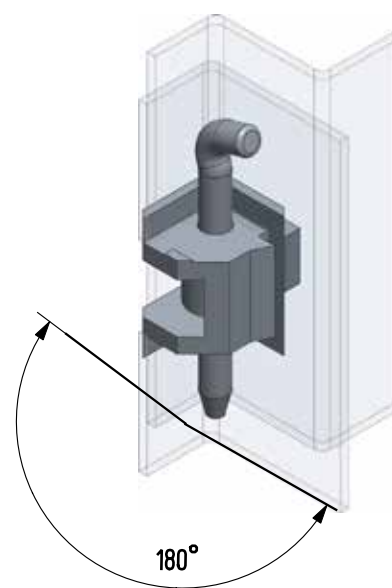
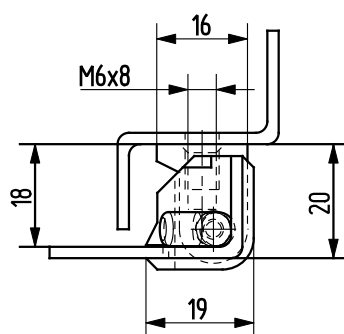

Termékszám	Alapanyag	Felületkezelés
90ZA-KZS001-04	cinköntvény	krómozva

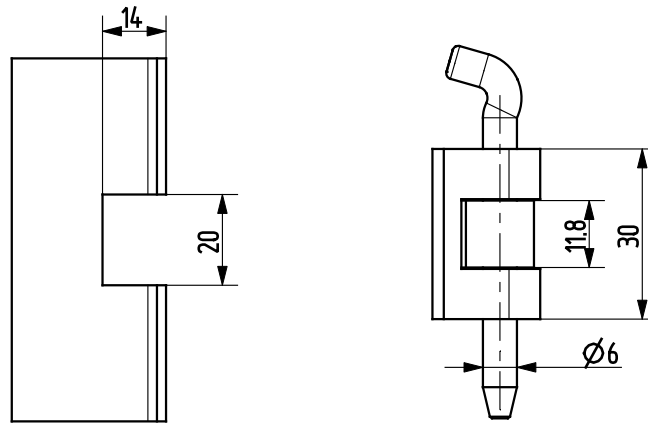
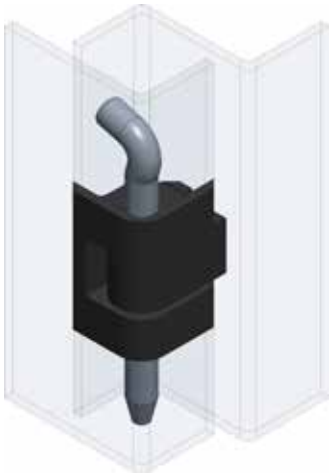

Ajtókibontás

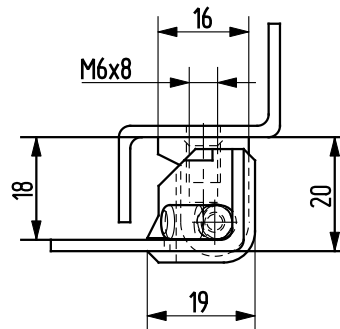
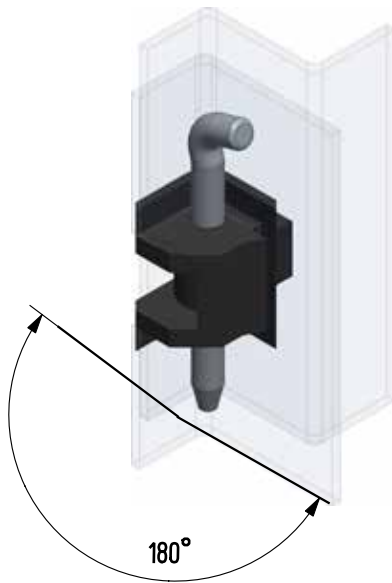

Termékszám	Alapanyag	Felületkezelés
90ZA-KZS001-06	cinköntvény	fekete porszórt

Zsanérok

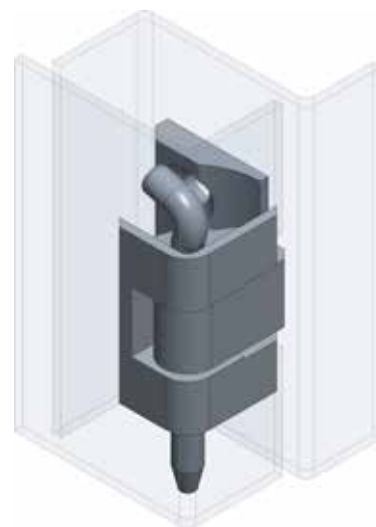
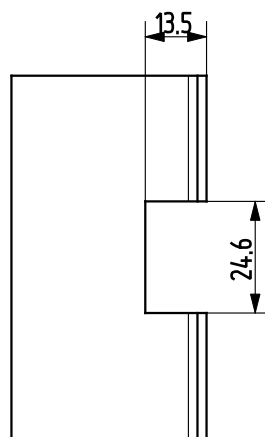
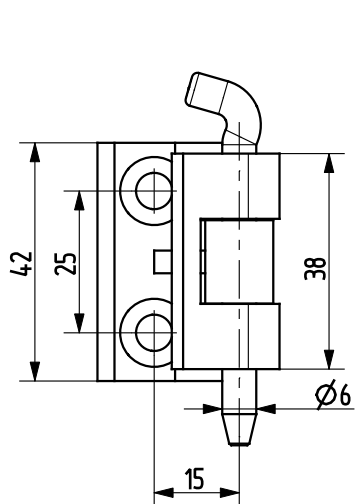

Ajtókibontás

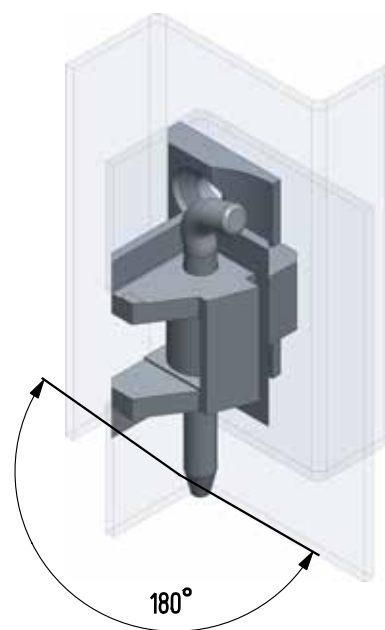
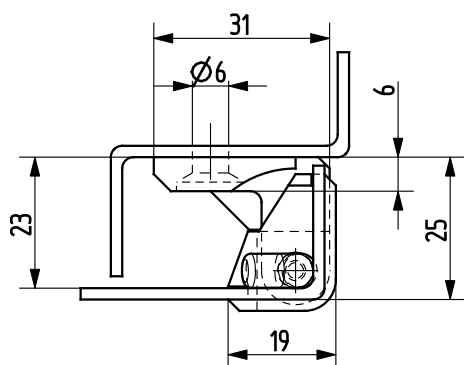

Termékszám	Alapanyag	Felületkezelés
90ZA-KZS001-04	cinköntvény	krómozva

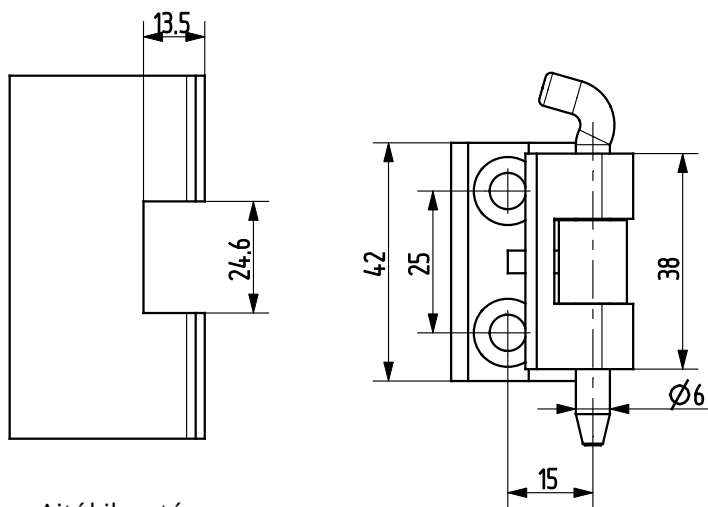

Ajtókibontás

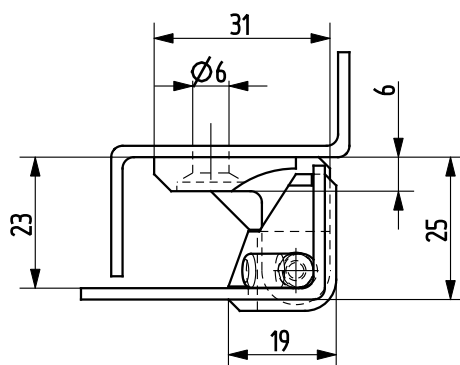
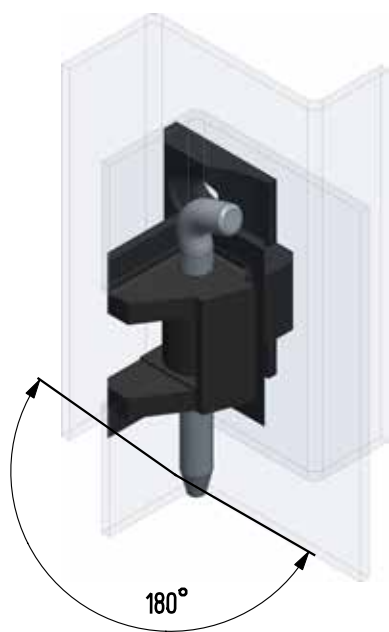

Termékszám

90ZA-KZS013-06

Alapanyag

cinköntvény

Felületkezelés

fekete porszórt

Zsanérok

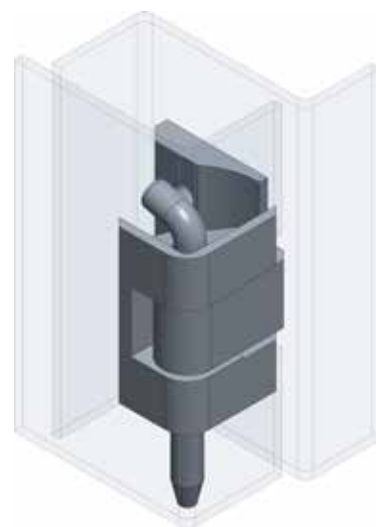
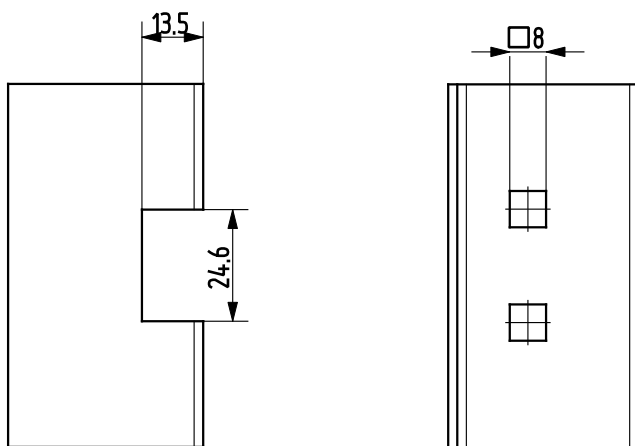

Ajtókibontás

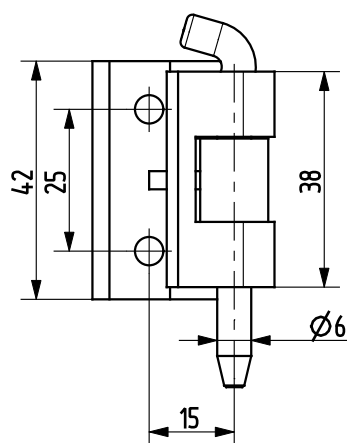
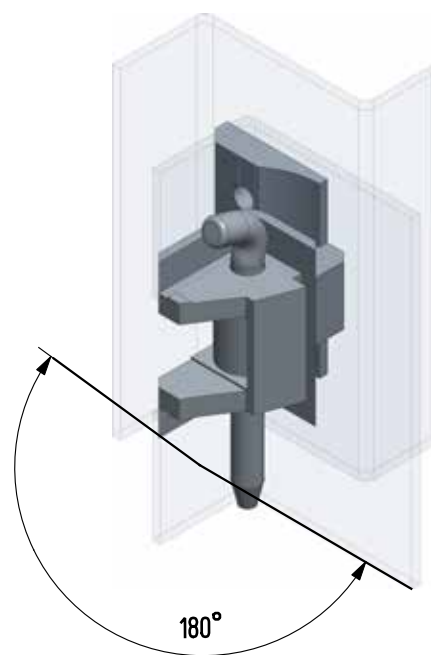
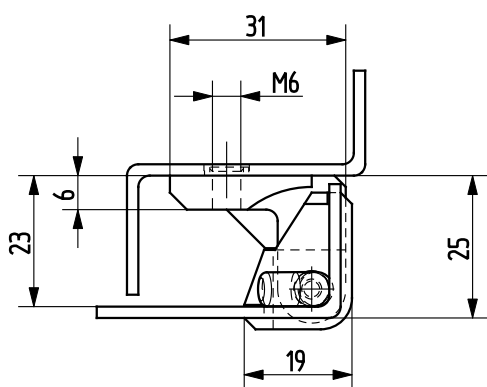

Termékszám	Alapanyag	Felületkezelés
90ZA-KZS014-04	cinköntvény	krómozva

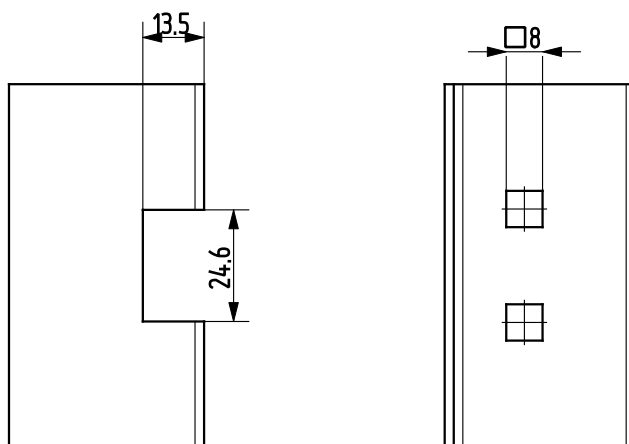
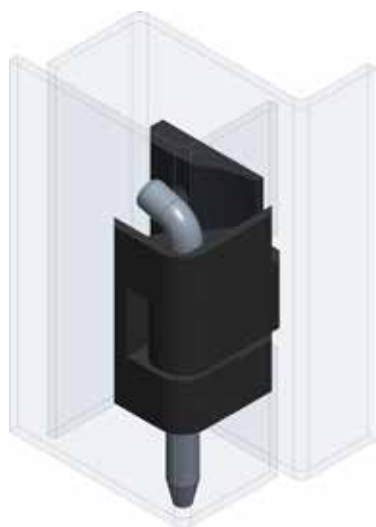

Ajtókibontás

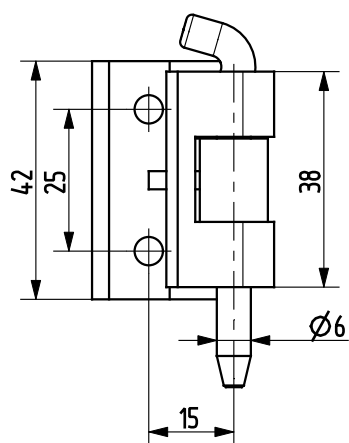
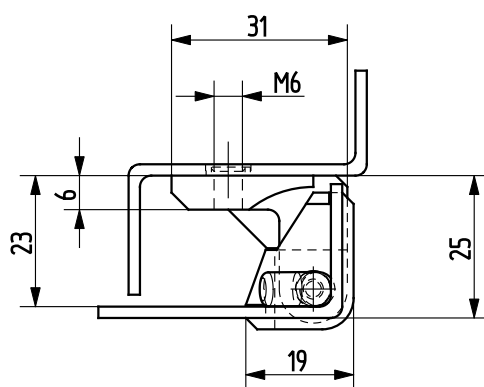
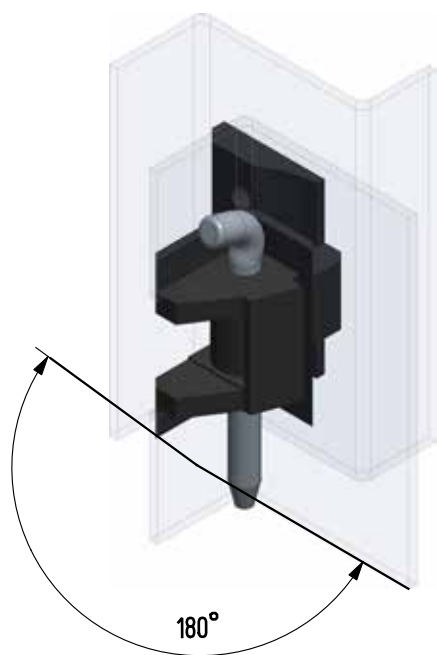

Termékszám	Alapanyag	Felületkezelés
90ZA-KZS014-06	cinköntvény	fekete porszórt

Zsanérok

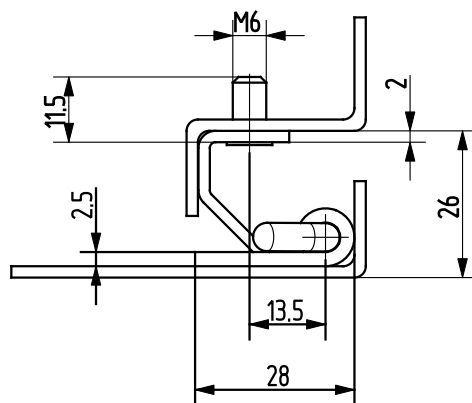
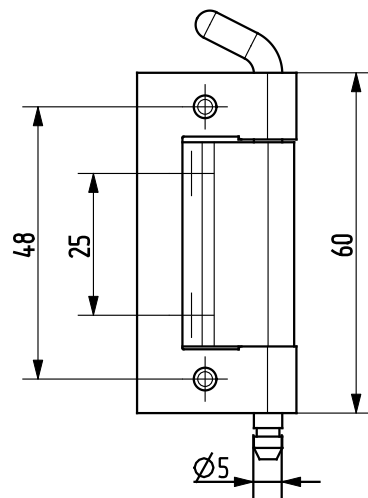

Termékszám	Alapanyag	Felületkezelés
90KO-KZS002-00	1.4301	-

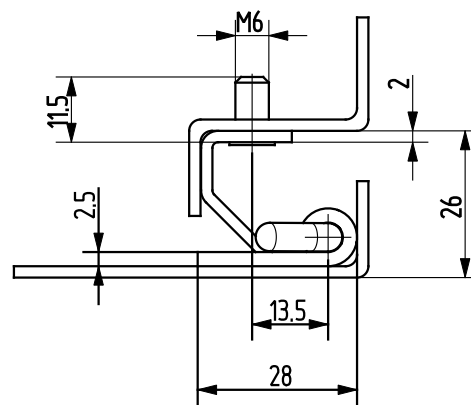
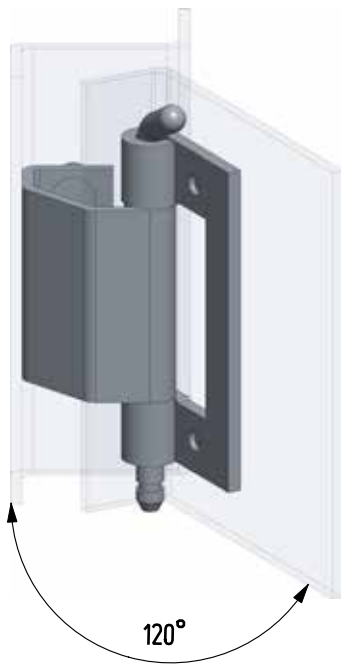
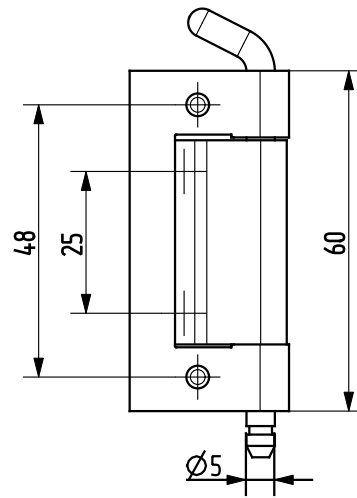

Termékszám	Alapanyag	Felületkezelés
90ST-KZS003-01	ST	horganyozva

Zsanérok

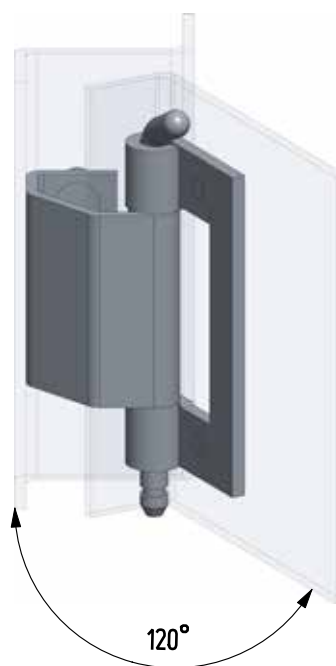
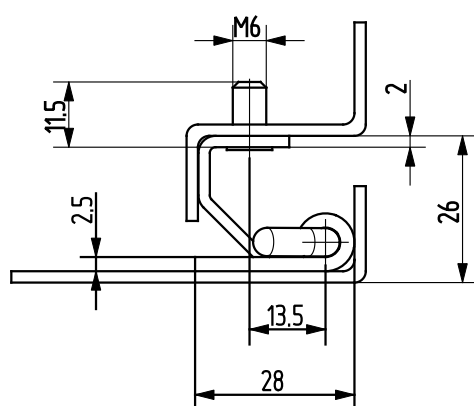
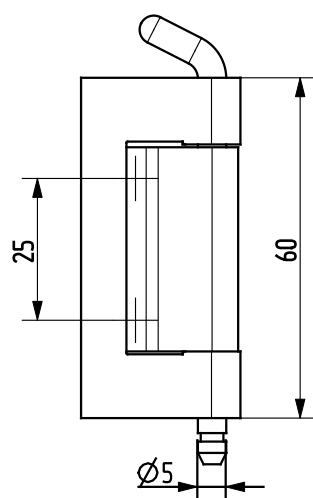

Termékszám	Alapanyag	Felületkezelés
90ST-KZS008-01	ST	horganyozva

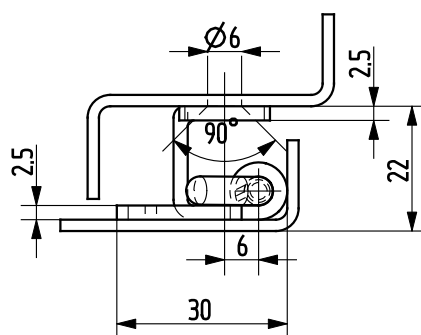
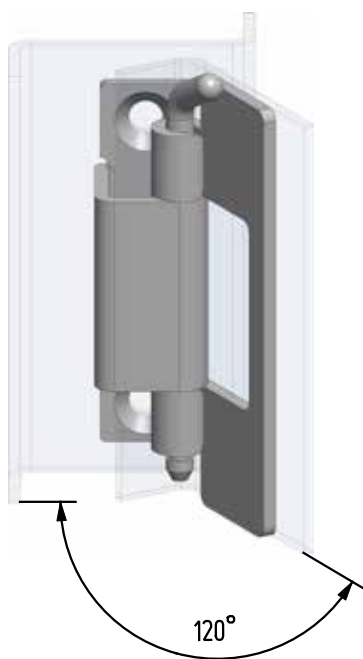
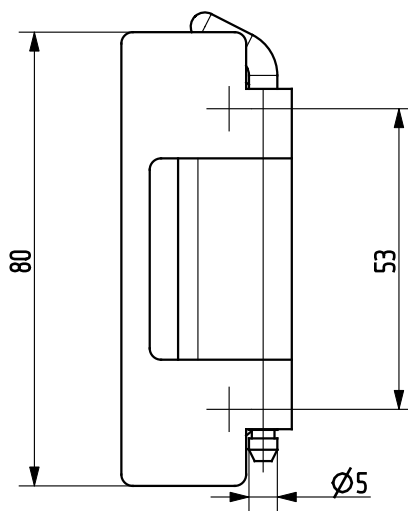
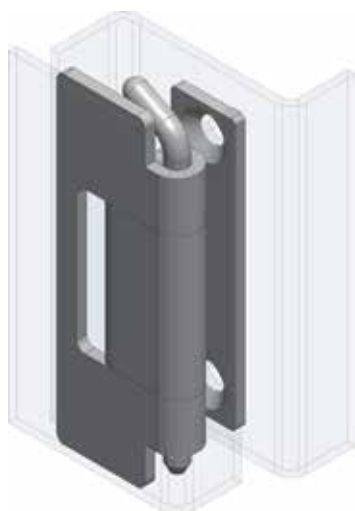

Termékszám	Alapanyag	Felületkezelés
90KO-KZS026-00	1.4301	-

Zsanérok

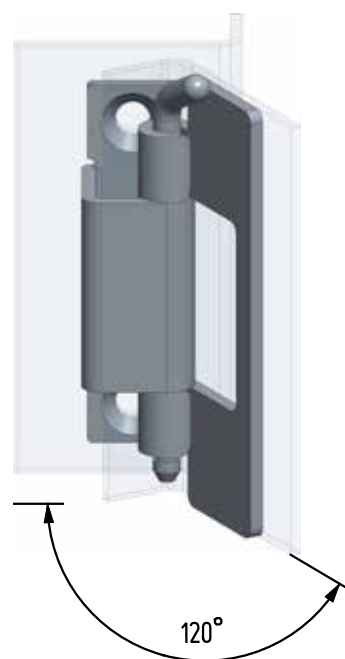
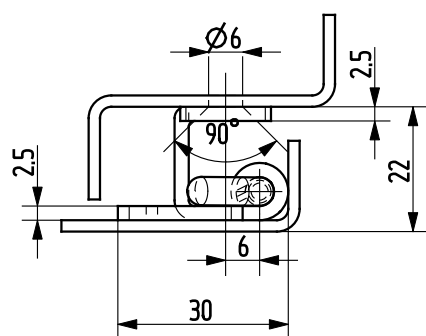
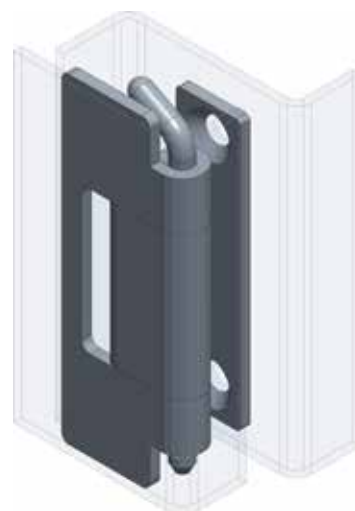
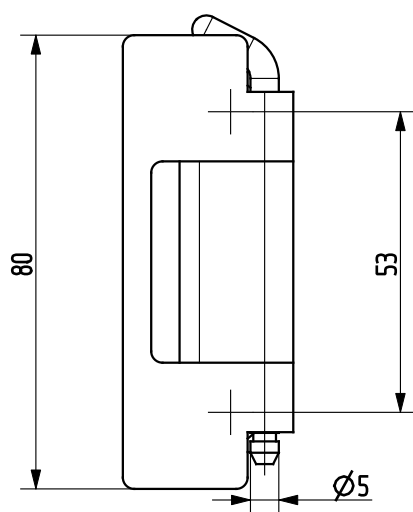

Termékszám	Alapanyag	Felületkezelés
90ST-KZS010-01	ST	horganyozva

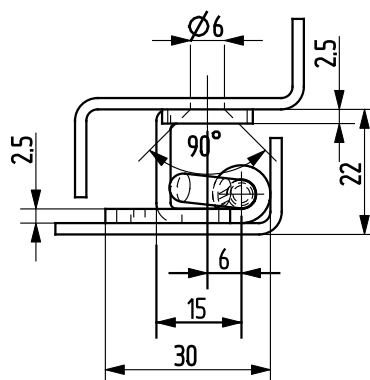
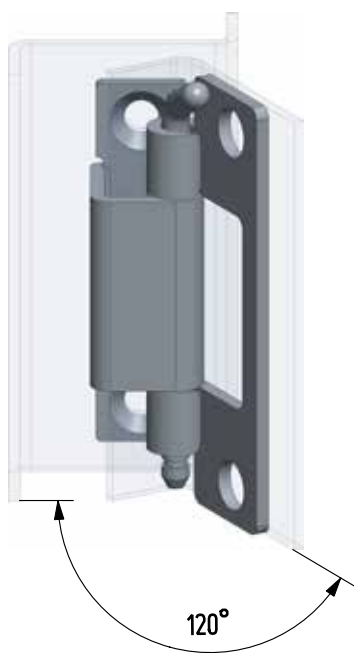
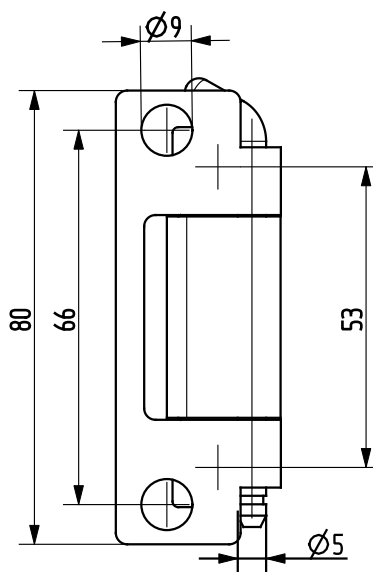

Termékszám	Alapanyag	Felületkezelés
90ST-KZS026-01	ST	horganyozva

Zsanérok

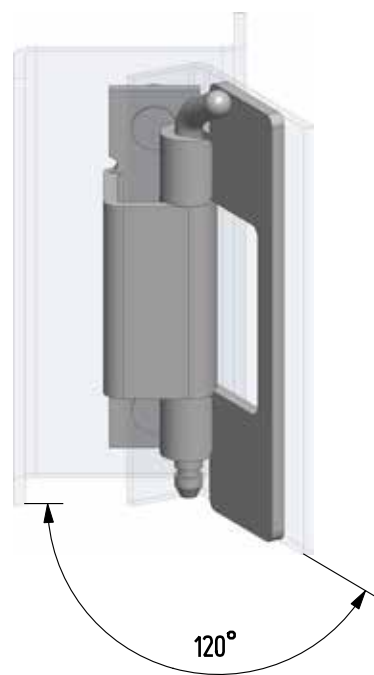
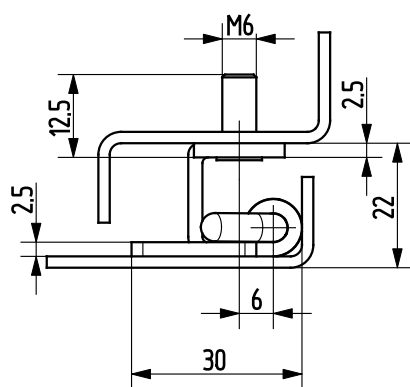
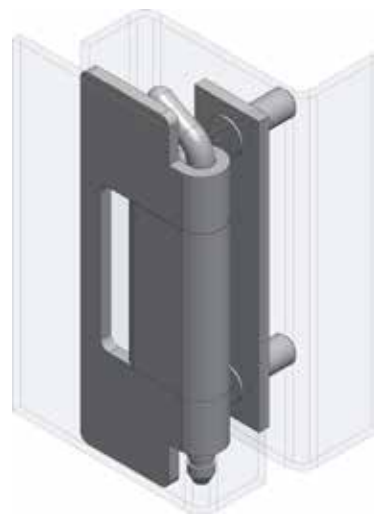
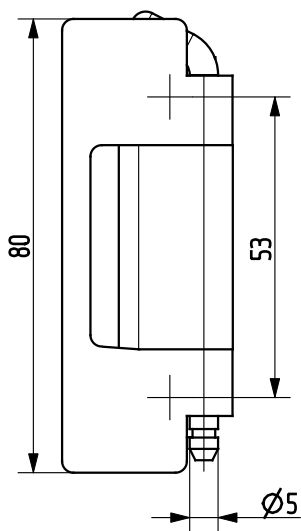

Termékszám	Alapanyag	Felületkezelés
90KO-KZS027-00	1.4305	-

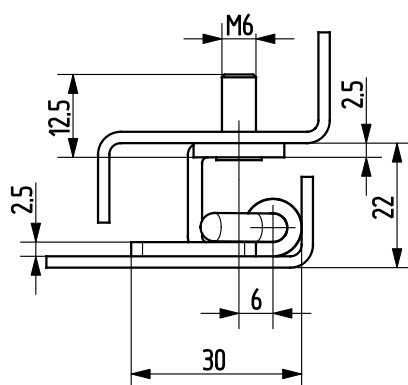
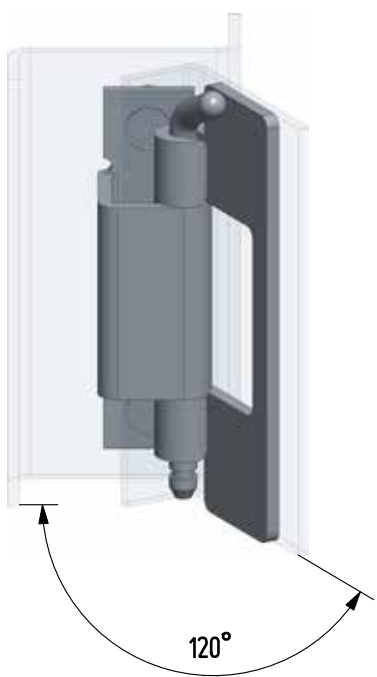
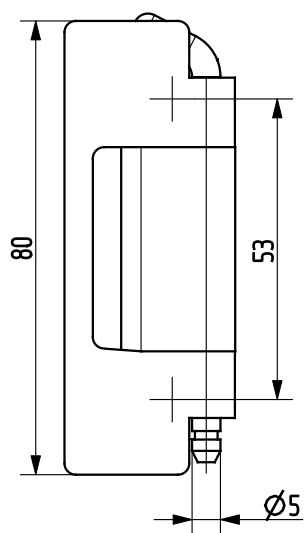
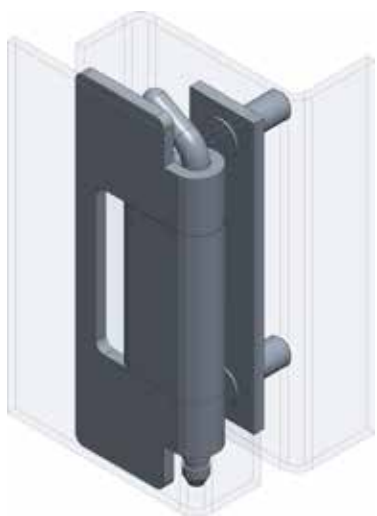

Termékszám	Alapanyag	Felületkezelés
90ST-KZS011-01	ST	horganyozva

Zsanérok

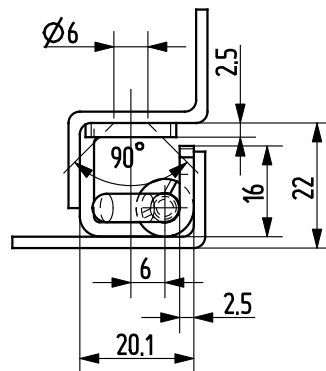
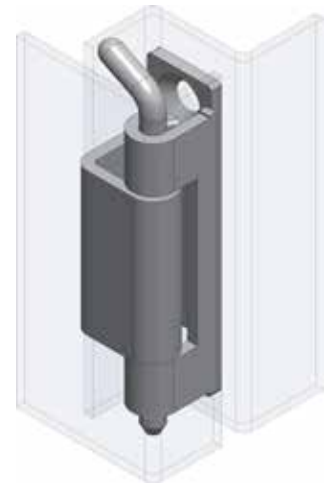
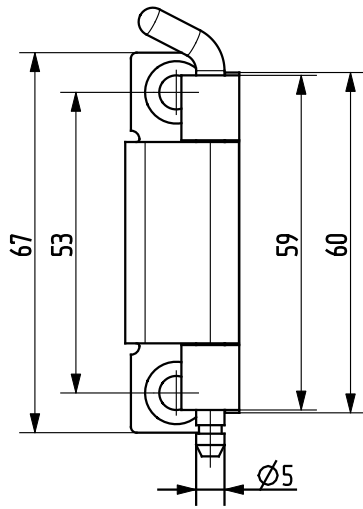

Termékszám	Alapanyag	Felületkezelés
90KO-KZS041-00	1.4301	-

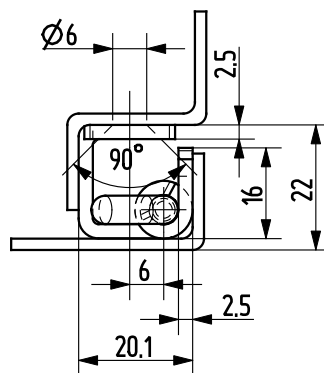
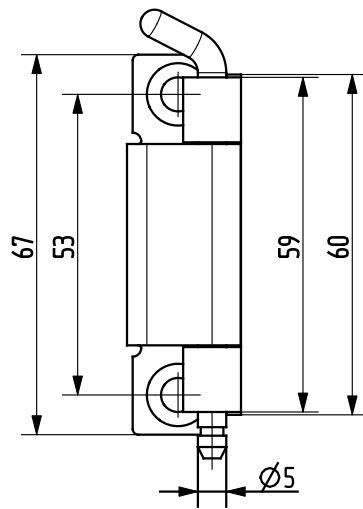

Termékszám	Alapanyag	Felületkezelés
90ST-KZS012-01	ST	horganyozva

Zsanérok

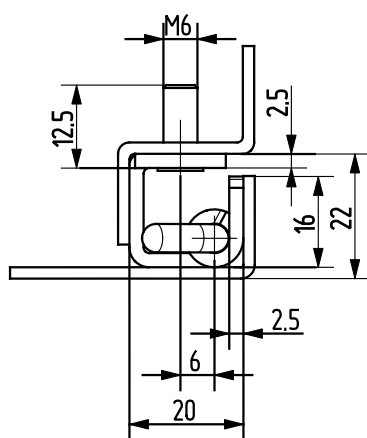
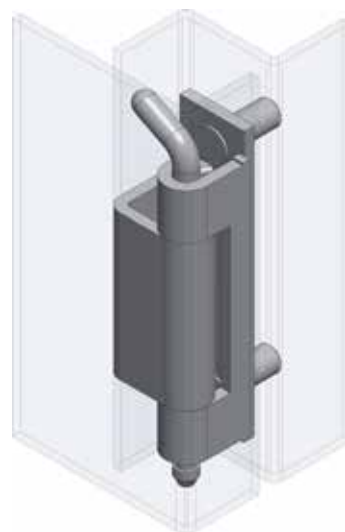
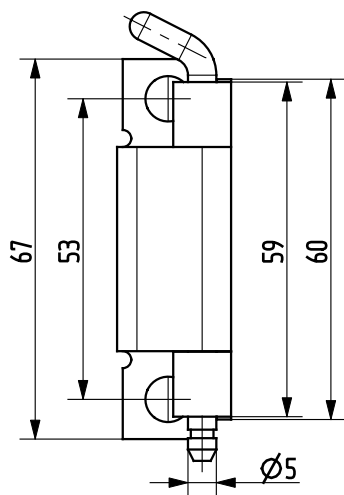

Termékszám	Alapanyag	Felületkezelés
90KO-KZS042-00	1.4301	-

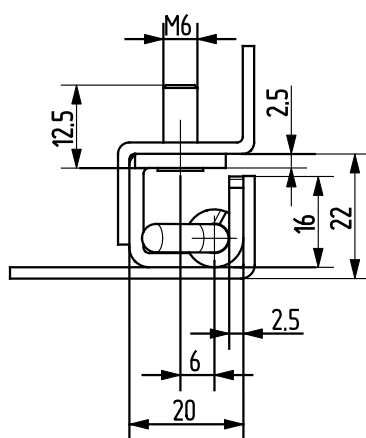
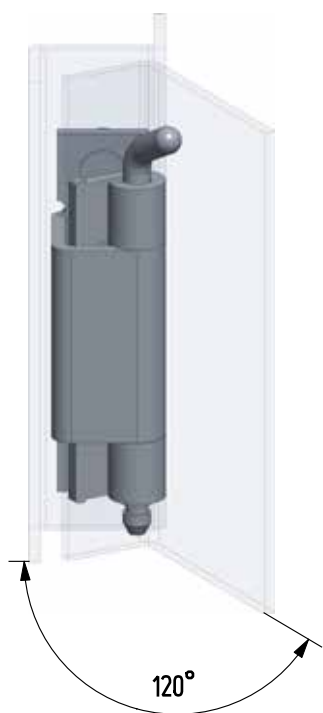
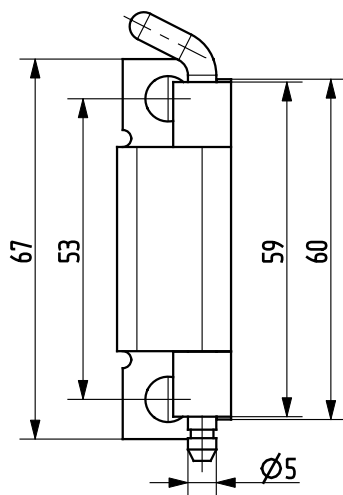
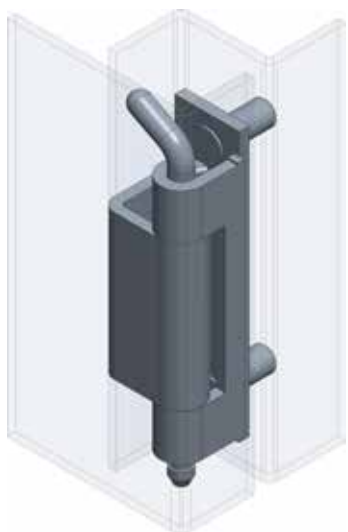

Termékszám	Alapanyag	Felületkezelés
90ST-KZS013-01	ST	horganyozva

Zsanérok

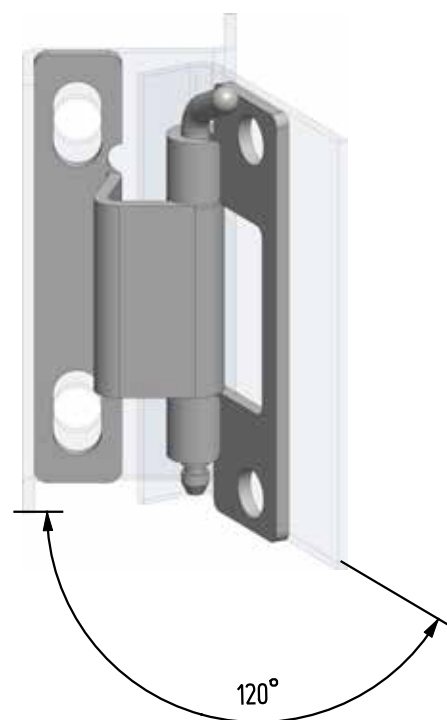
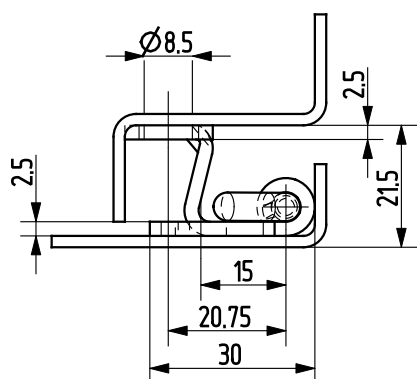
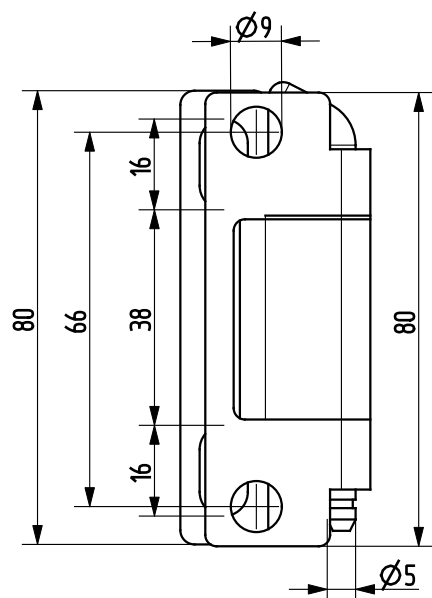

Termékszám	Alapanyag	Felületkezelés
90KO-KZS050-00	1.4301	-
90KO-KZS003-00	1.4571	-

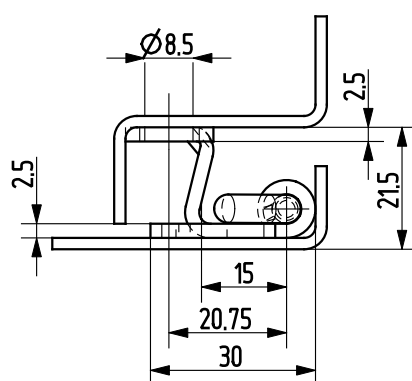
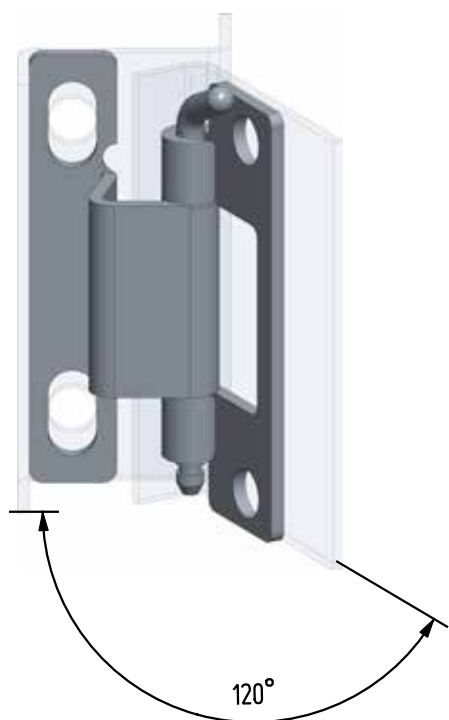
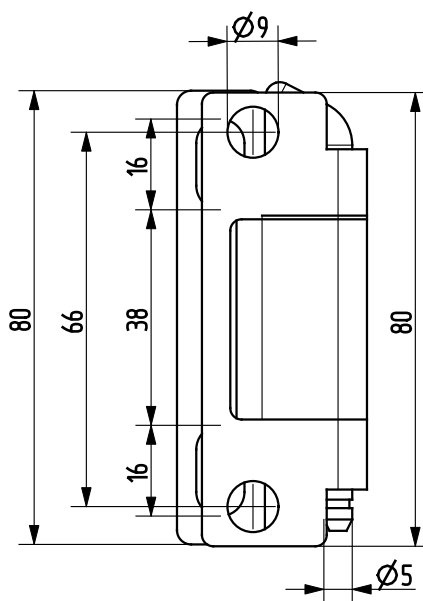
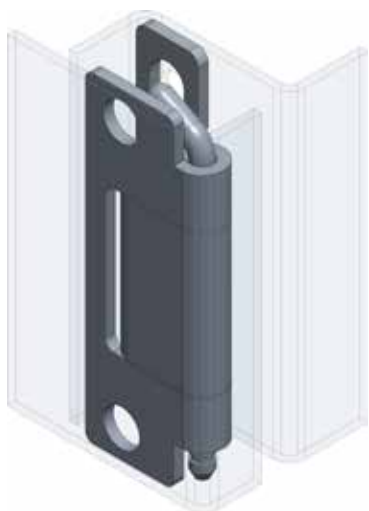

Termékszám	Alapanyag	Felületkezelés
90ST-KZS015-01	ST	horganyozva

Zsanérok

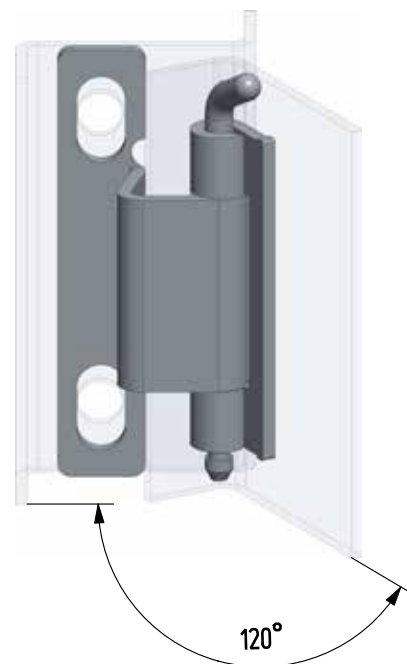
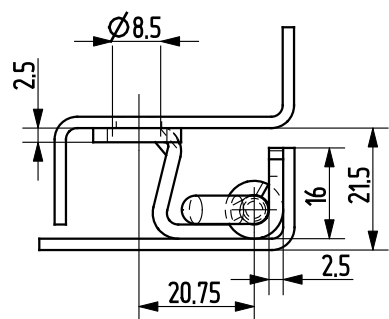
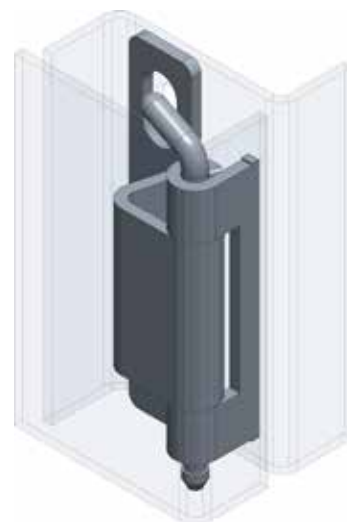
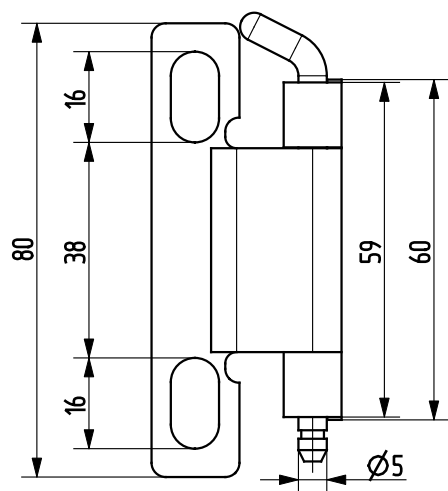

Termékszám	Alapanyag	Felületkezelés
90ST-KZS019-01	ST	horganyozva

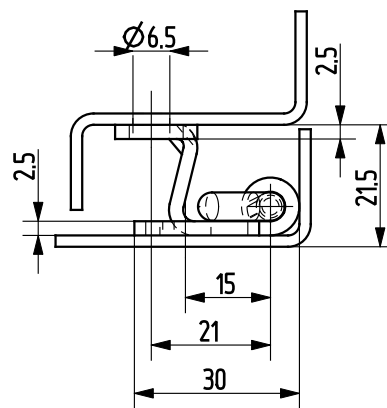
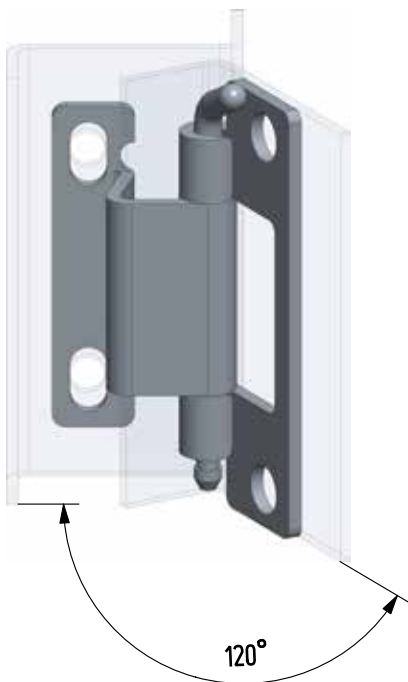
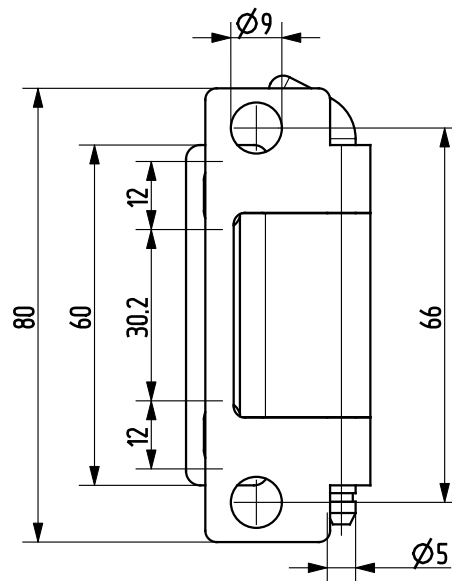

Termékszám	Alapanyag	Felületkezelés
90ST-KZS034-01	ST	horganyozva

Zsanérok

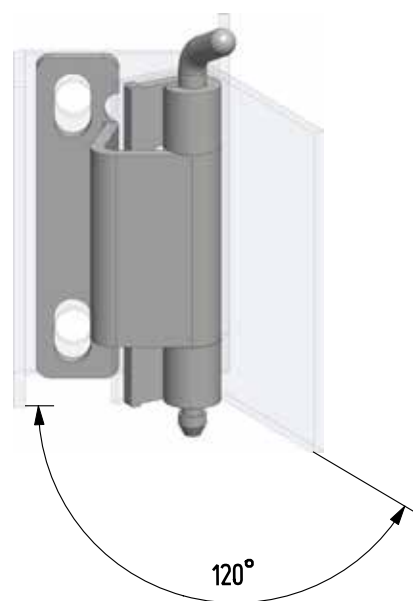
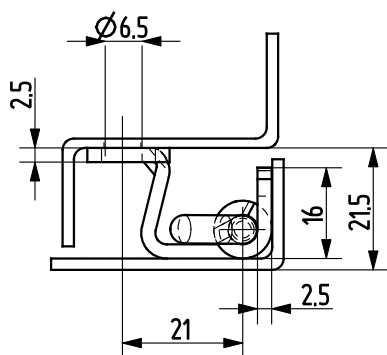
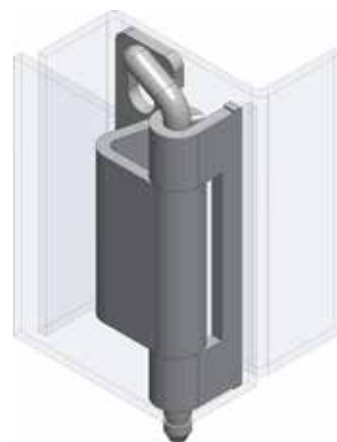
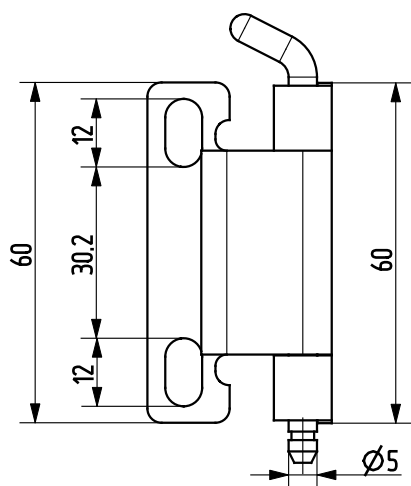

Termékszám	Alapanyag	Felületkezelés
90KO-KZS043-00	1.4301	-
90KO-KZS051-00	1.4571	-

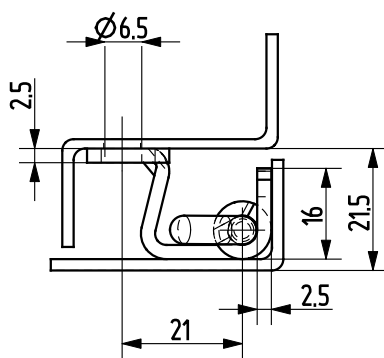
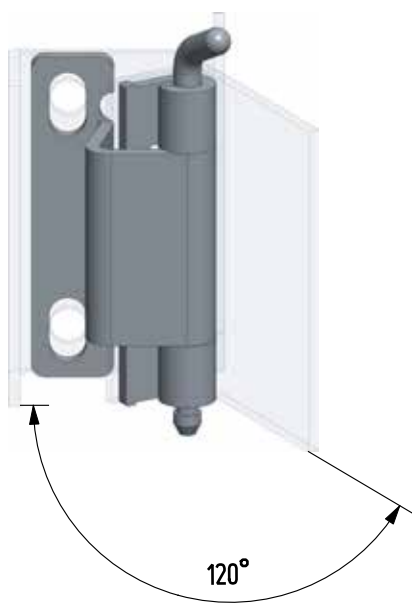
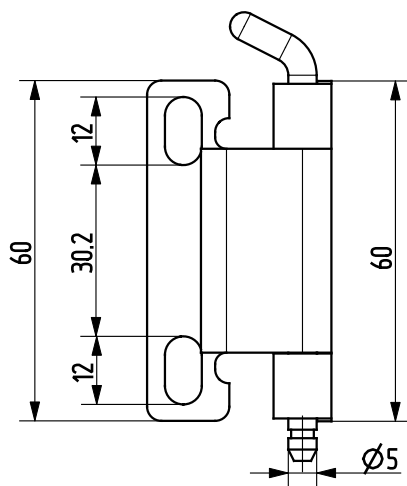
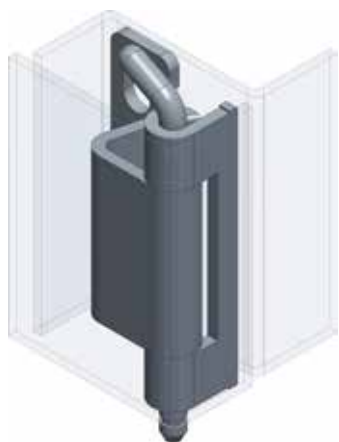

Termékszám	Alapanyag	Felületkezelés
90ST-KZS014-01	ST	horganyozva

Zsanérok

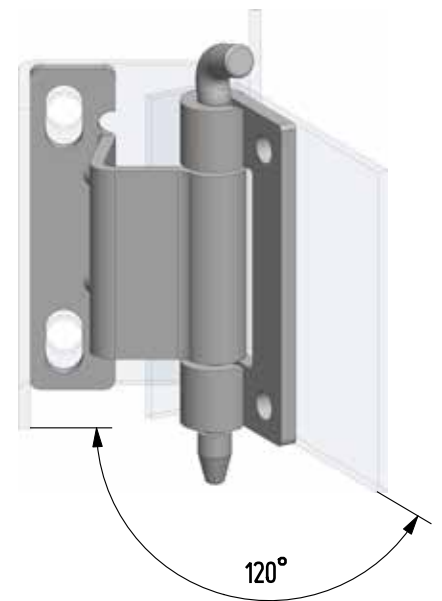
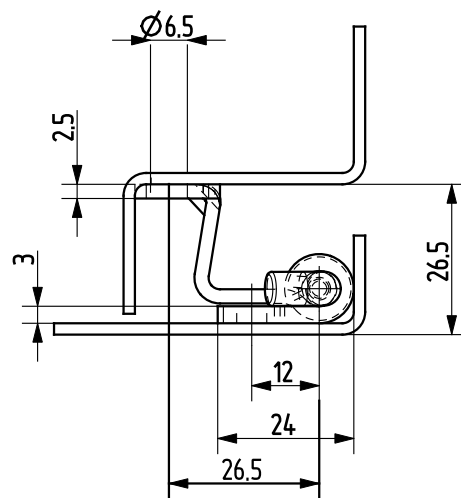
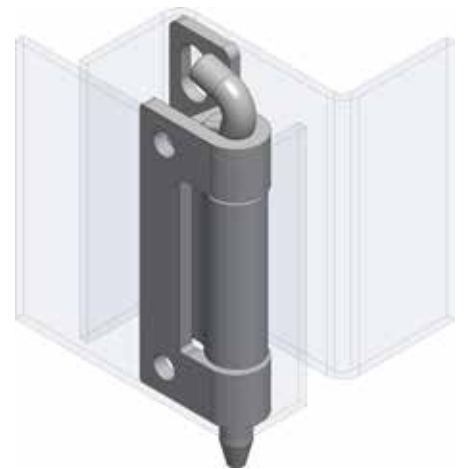
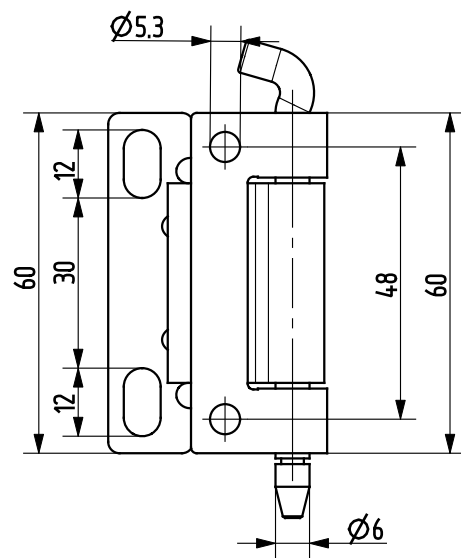

Termékszám	Alapanyag	Felületkezelés
90KO-KZS070-00	1.4301	-

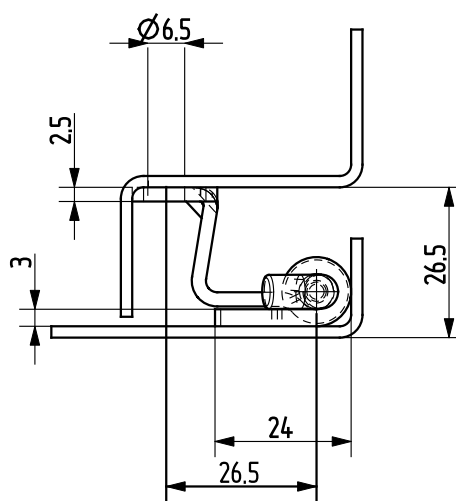
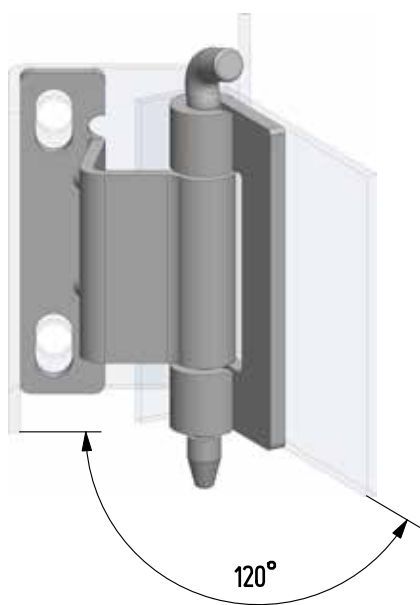
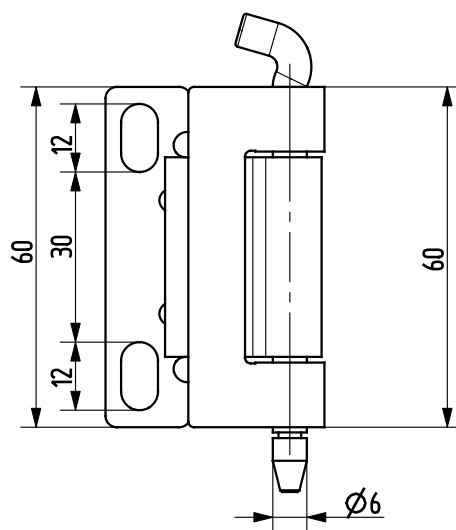
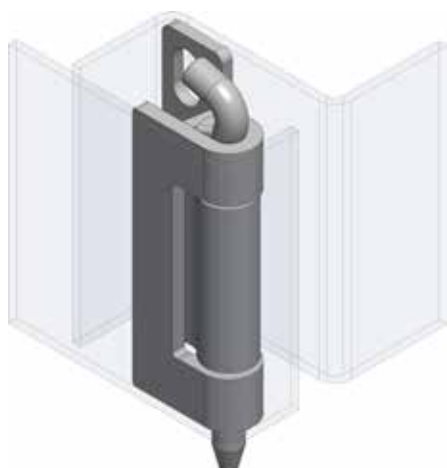

Termékszám	Alapanyag	Felületkezelés
90KO-KZS071-00	1.4301	-

Zsanérok

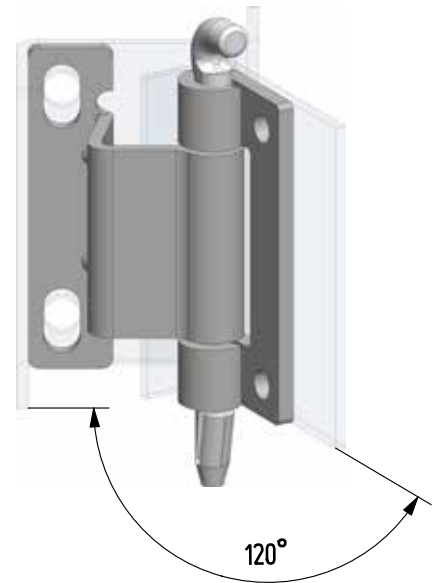
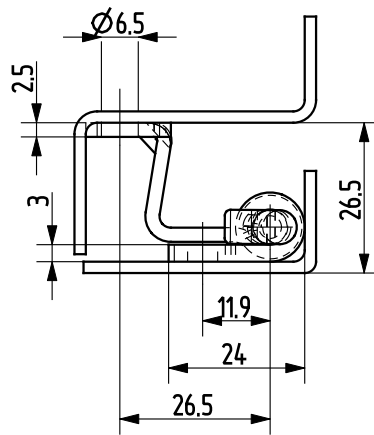
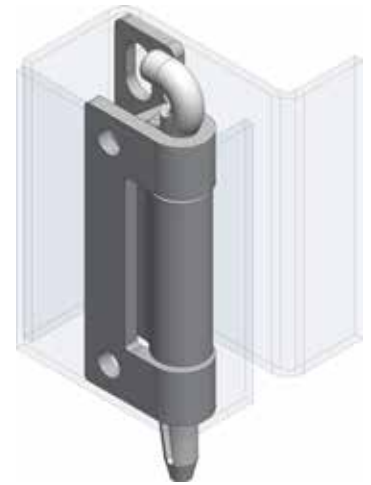
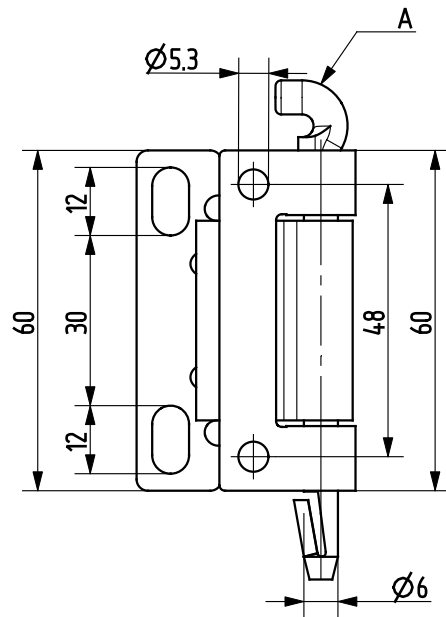

Megjegyzés „A”:
rögzítő csap
alapanyaga PA

Termékszám	Alapanyag	Felületkezelés
90KO-KZS072-00	1.4301	-

Zsanérok

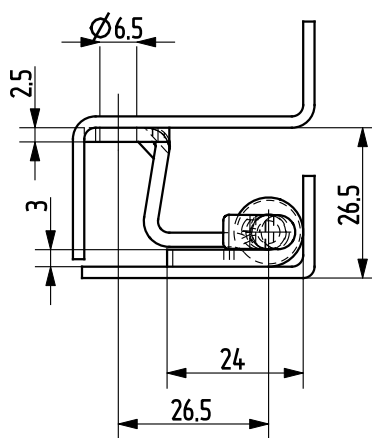
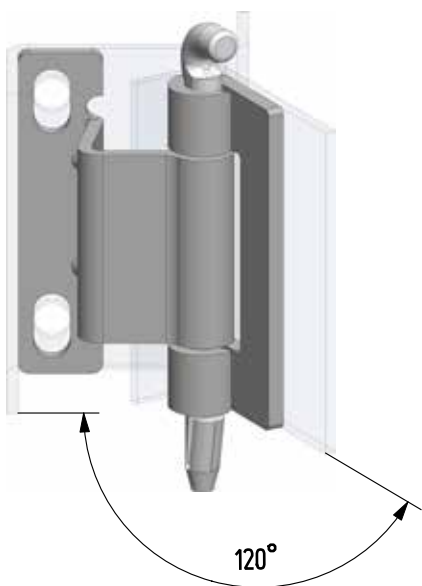
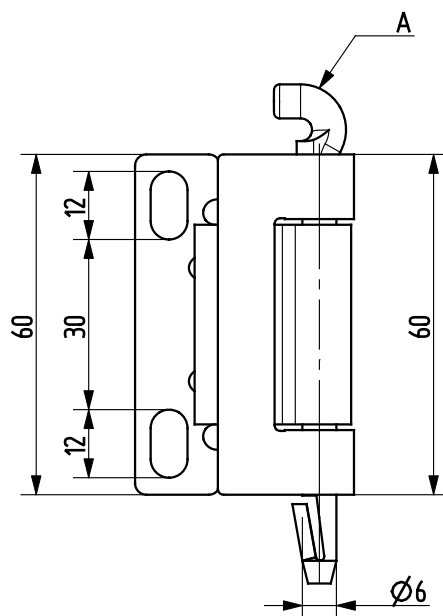
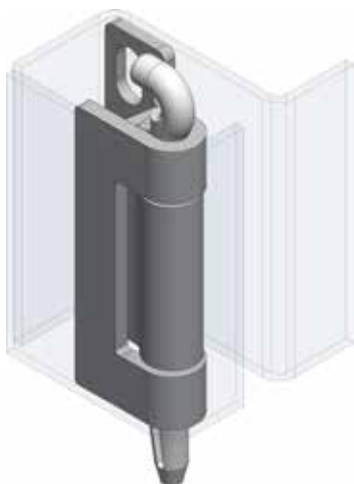

Termékszám	Alapanyag	Felületkezelés
90KO-KZS073-00	1.4301	-

Megjegyzés „A”:
rögzítő csap
alapanyaga PA

Zsanérok

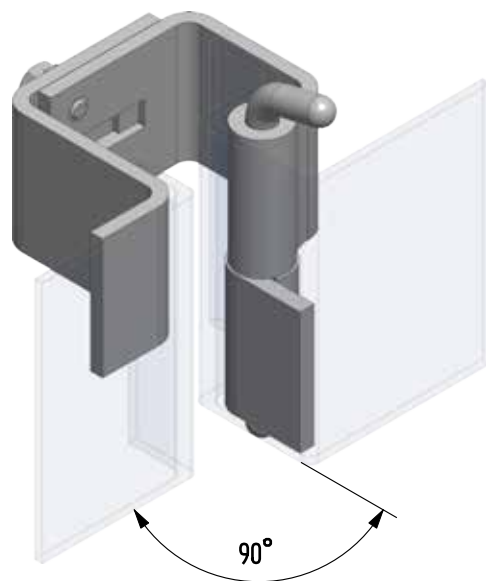
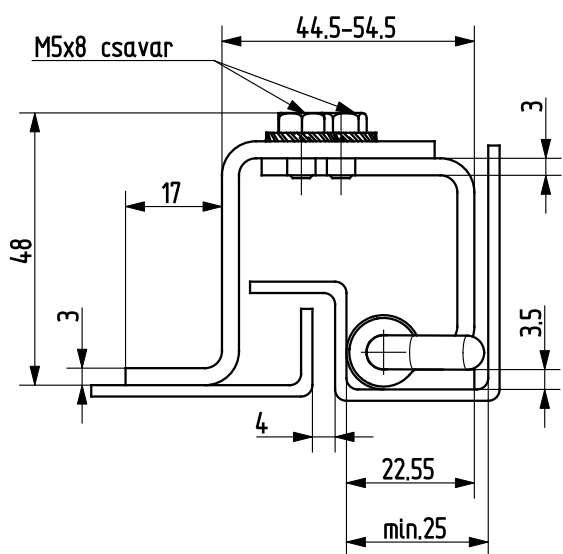
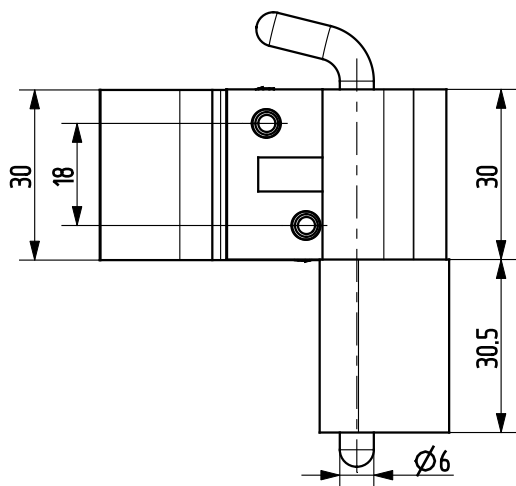

Termékszám	Alapanyag	Felületkezelés
90KO-KZS069-00	1.4301	-

Zsanérok

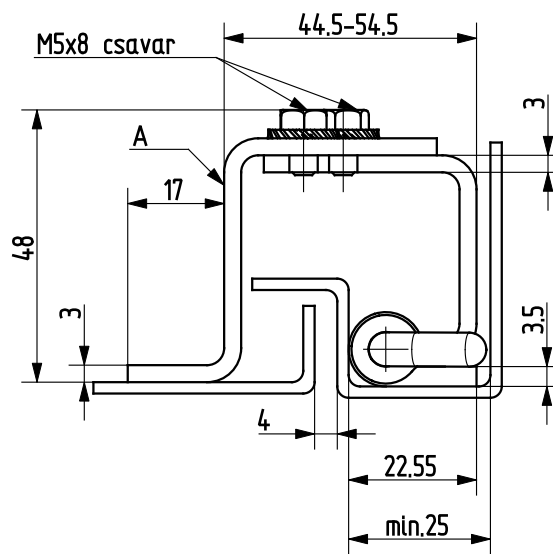
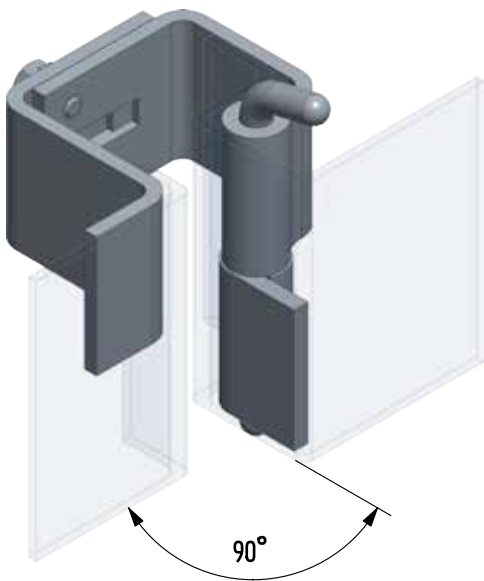
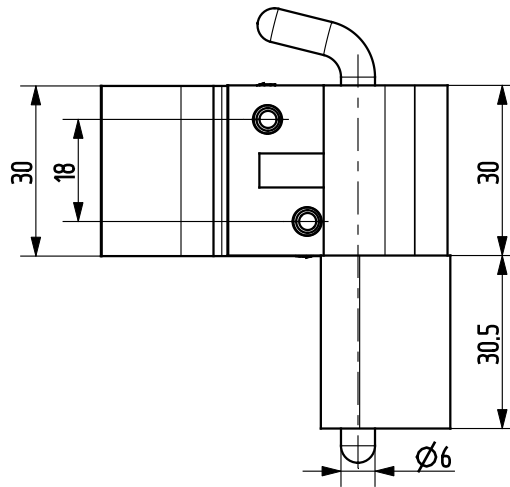

Termékszám	Alapanyag	Felületkezelés
90ST-KZS035-01	ST	horganyozva

Megjegyzés:
az „A”-val jelölt
alkatrész nincsen
felületkezelve

Zsanérok

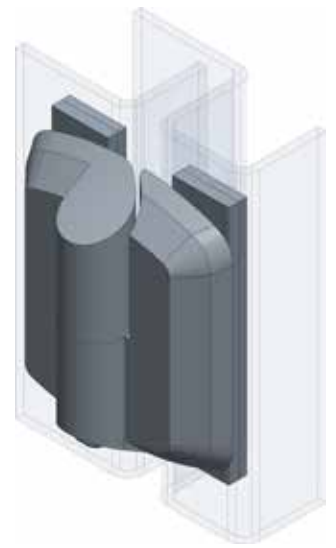
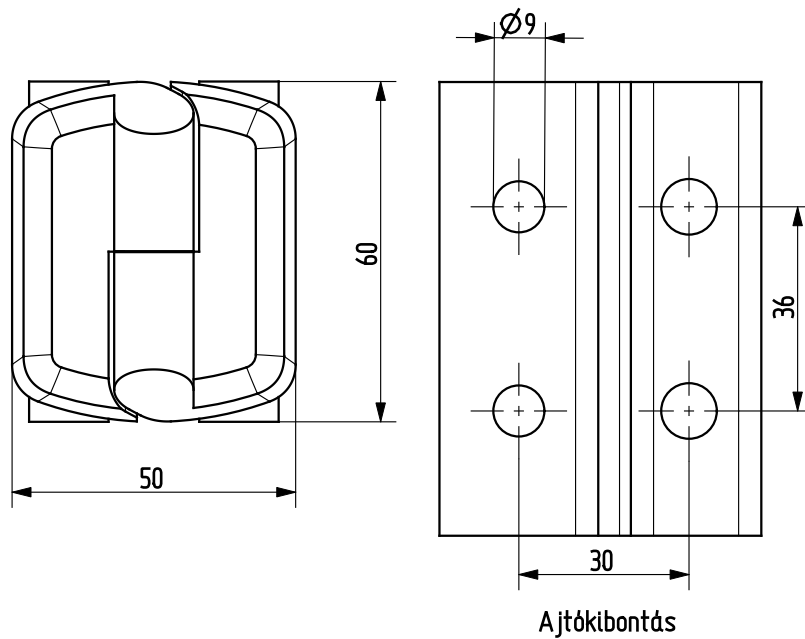

A képen a jobbos típus látható!
(balos típus a jobbos tükörképe)

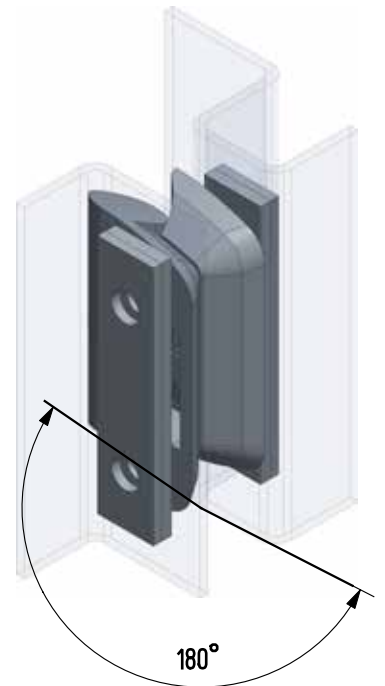
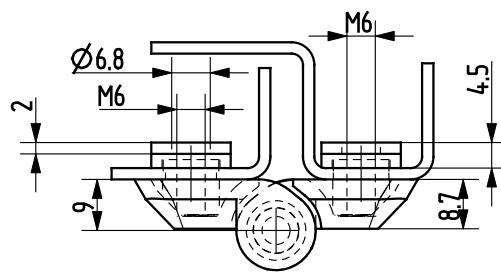

Termékszám	Alapanyag	Felületkezelés	Verzió
90KO-KZS083-11	1.4581	elektropolír	jobbos
90KO-KZS084-11	1.4581	elektropolír	balos

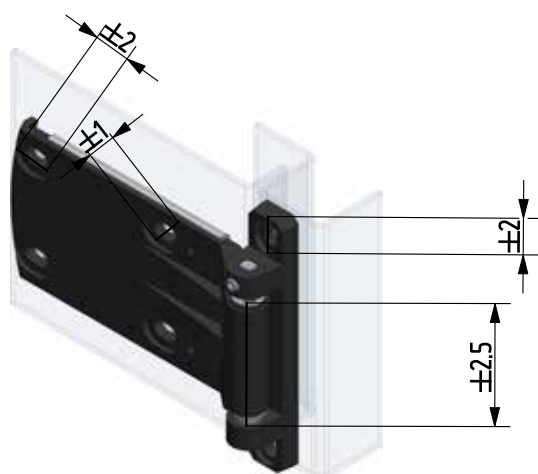

Külön rendelésre!

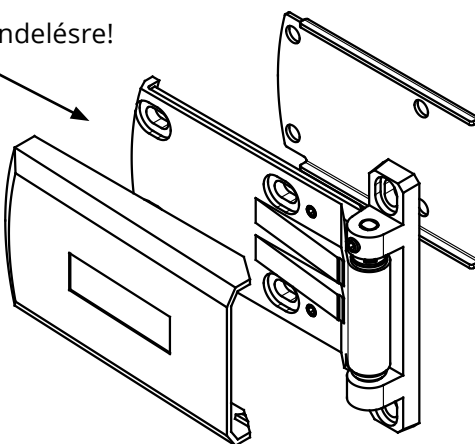

A képen a jobbos típus látható!
(balos típus a jobbos tükörképe)

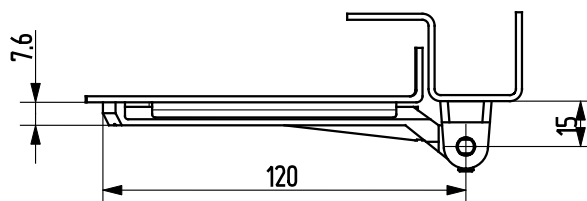
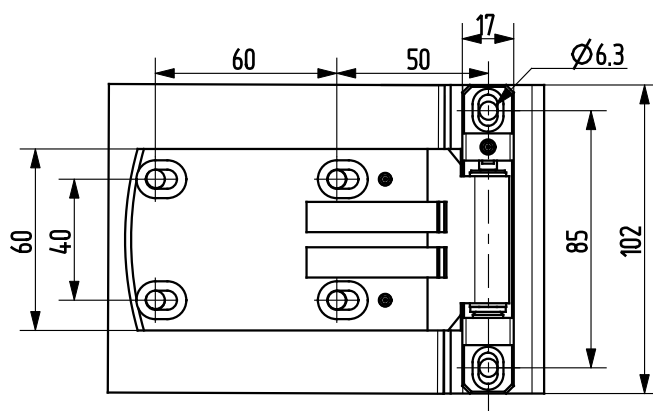
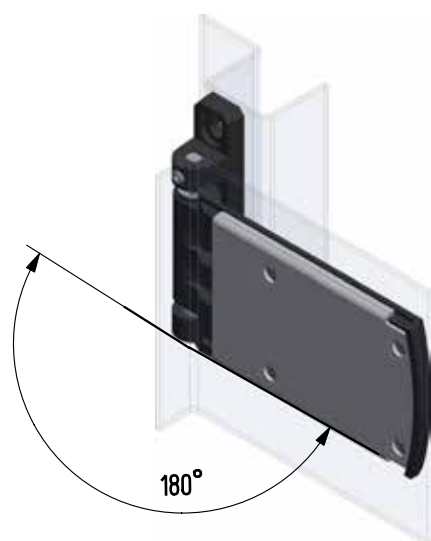

Termékszám	Alapanyag	Felületkezelés	Verzió
90ZA-KZS016-06	cinköntvény	fekete porszórt	jobbos
90ZA-KZS015-06	cinköntvény	fekete porszórt	balos

Termékszám	Alapanyag
90PA-HT002-00*	poliamid

Megjegyzés:
*külön rendelésre!

Zsanérok

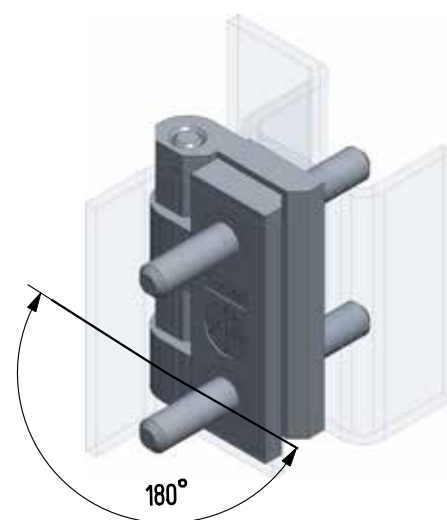
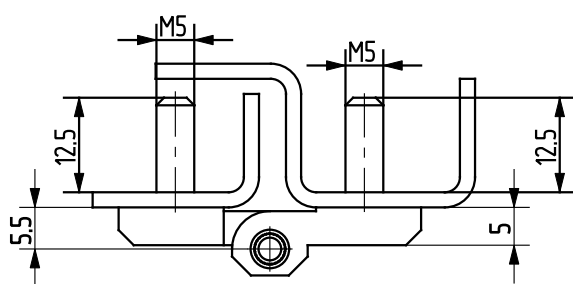
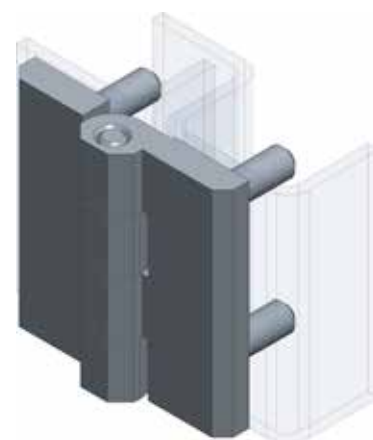
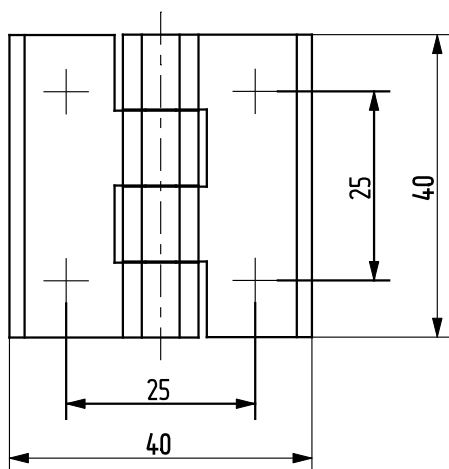

Termékszám	Alapanyag	Felületkezelés
90ZA-KZS026-04	cinköntvény	krómozva

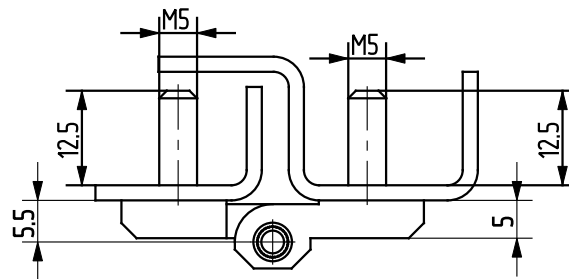
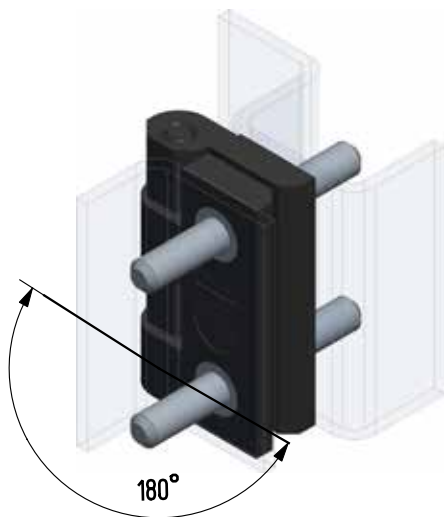
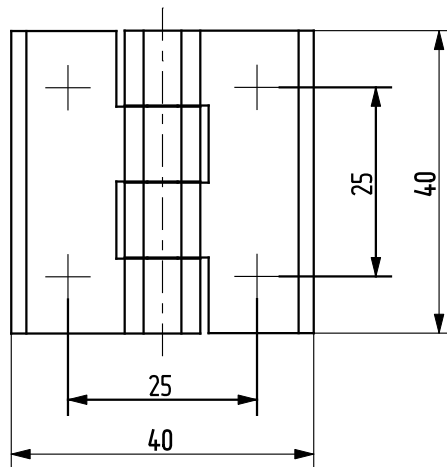
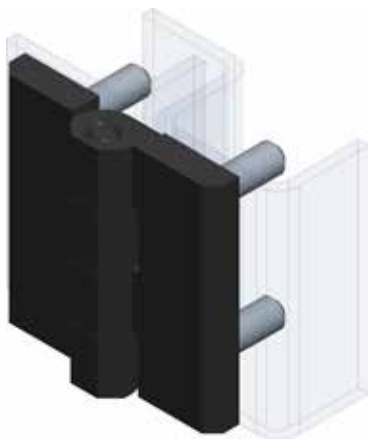

Termékszám	Alapanyag	Felületkezelés
90ZA-KZS026-06	cinköntvény	fekete porszórt

Zsanérok

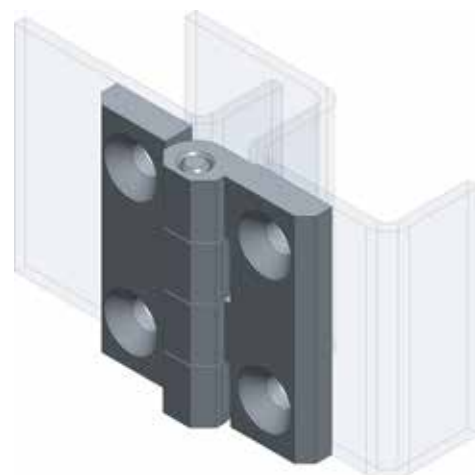
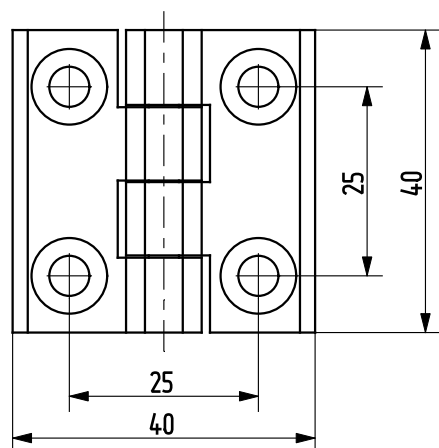

süllyesztés DIN 7991

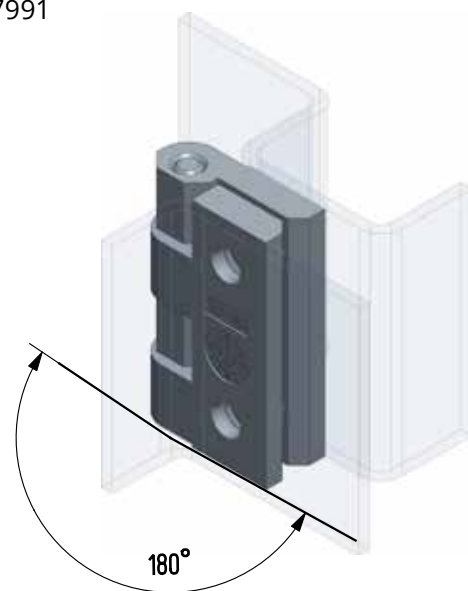
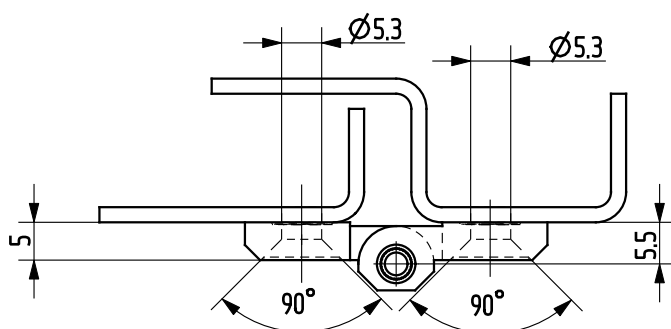

Termékszám	Alapanyag	Felületkezelés
90ZA-KZS027-04	cinköntvény	krómozva

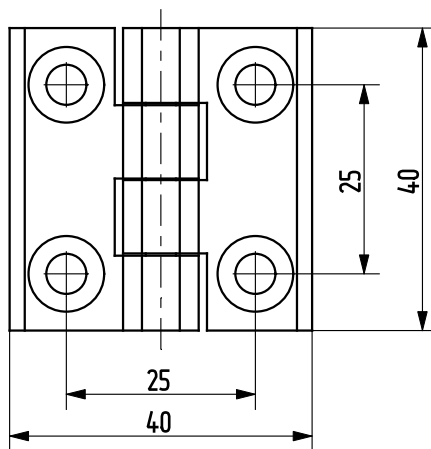

süllyesztés DIN 7991

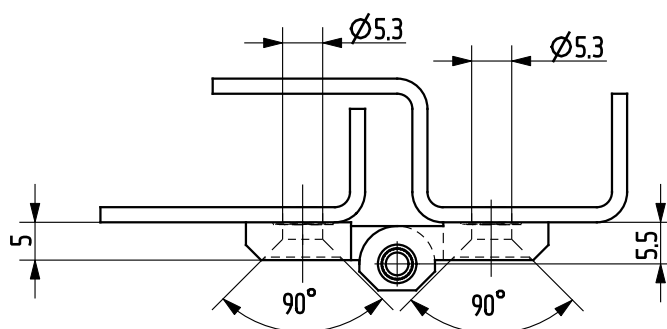
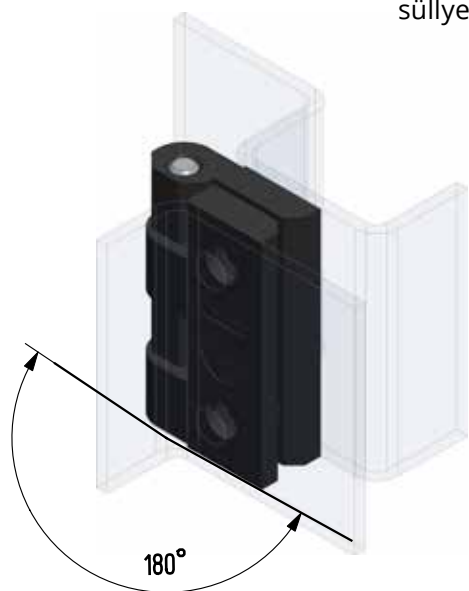

Termékszám	Alapanyag	Felületkezelés
90ZA-KZS027-06	cinköntvény	fekete porszórt

Zsanérok

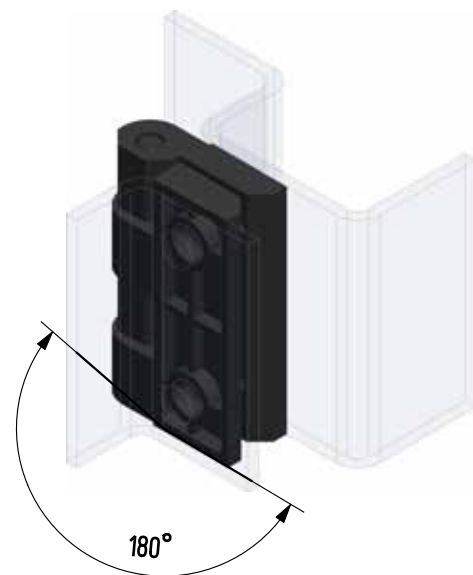
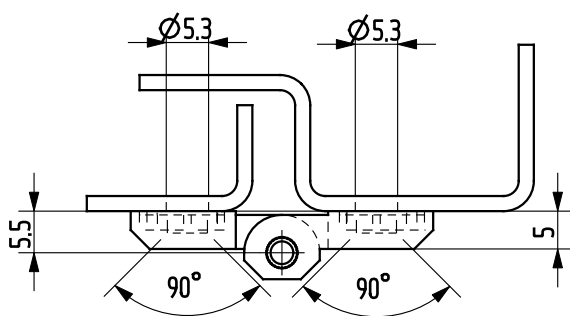
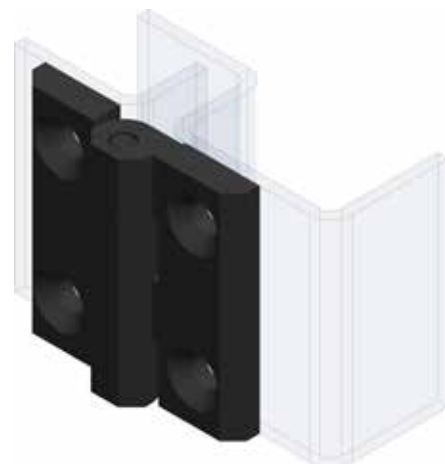
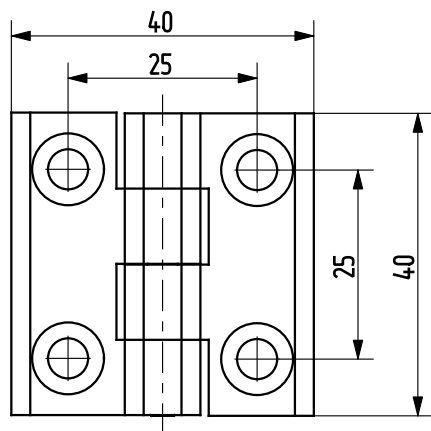

Termékszám	Alapanyag	Felületkezelés
90PA-KZS027-00	PA	-

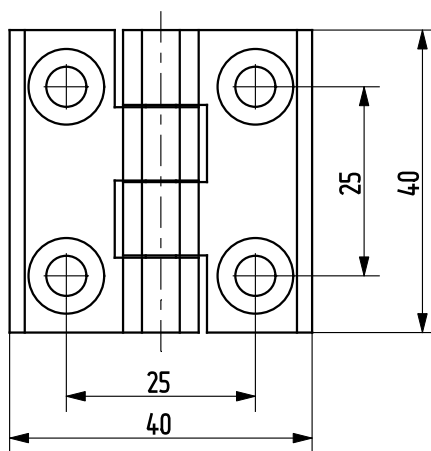
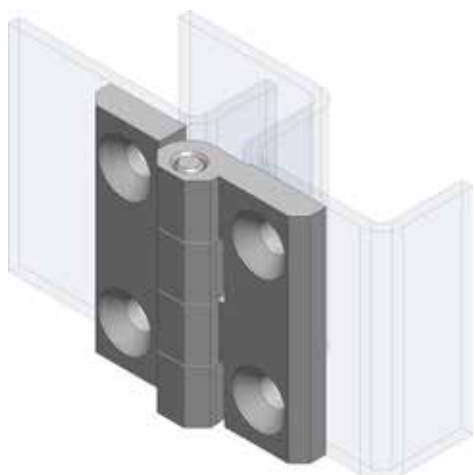

süllyesztés DIN 7991

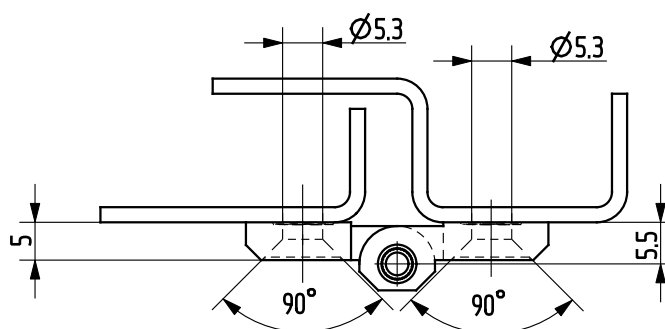
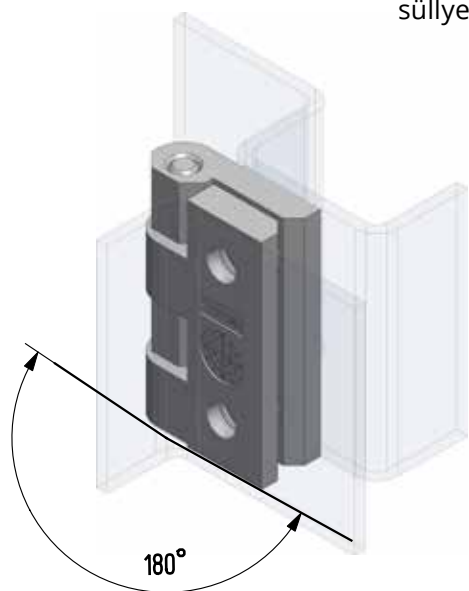

Termékszám	Alapanyag	Felületkezelés
90KO-KZS025-11	1.4571	elektropolír

Zsanérok

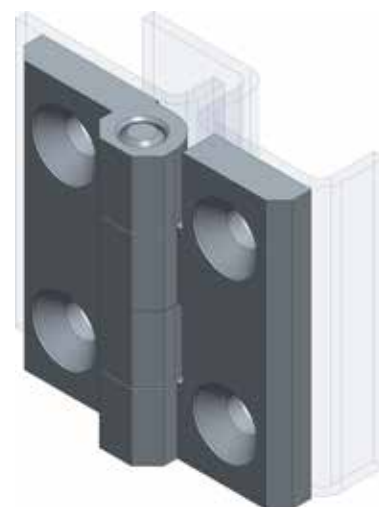
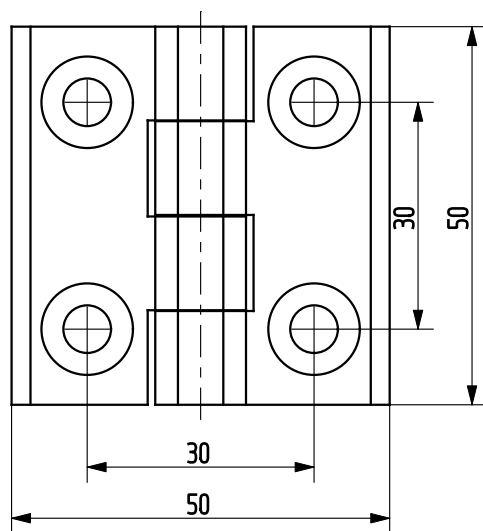

süllyesztés DIN 7991

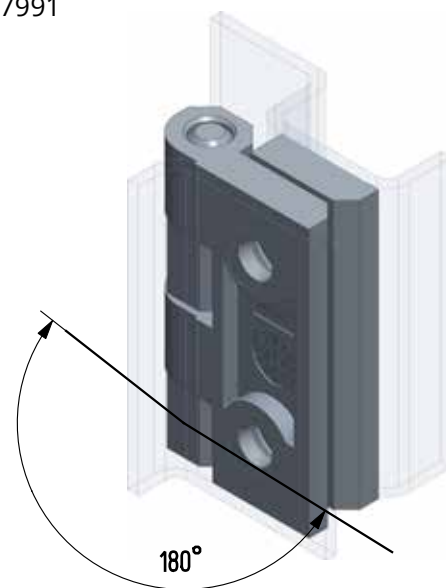
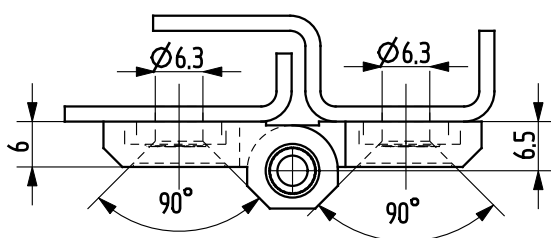

Termékszám	Alapanyag	Felületkezelés
90ZA-KZS029-04	cinköntvény	krómozva

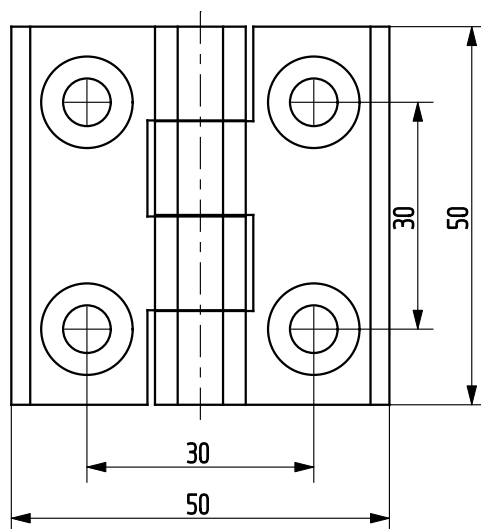
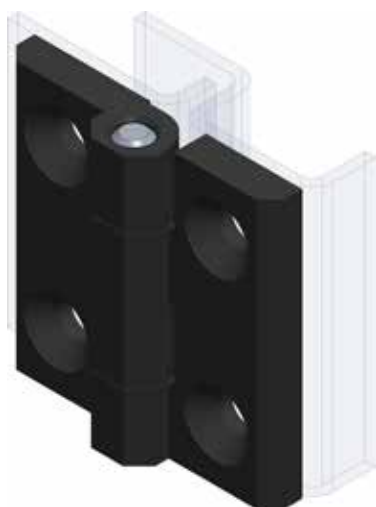

süllyesztés DIN 7991

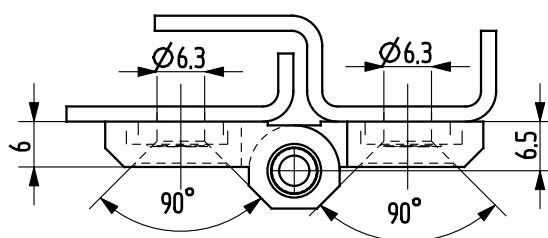
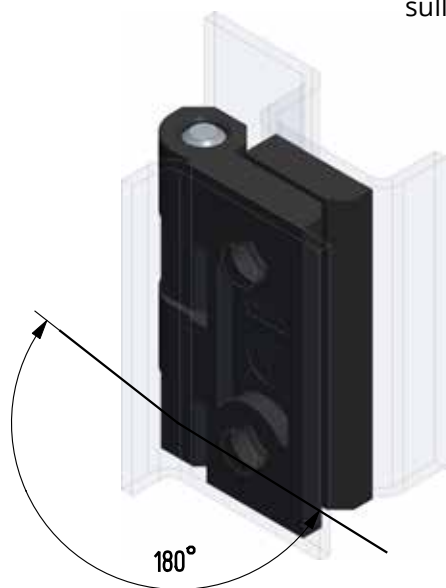

Termékszám

90ZA-KZS029-06

Alapanyag

cinköntvény

Felületkezelés

fekete porszórt

Zsanérok

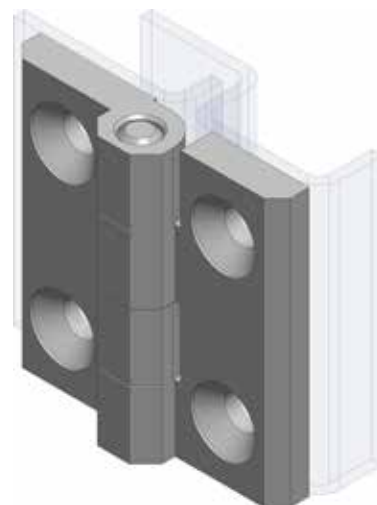
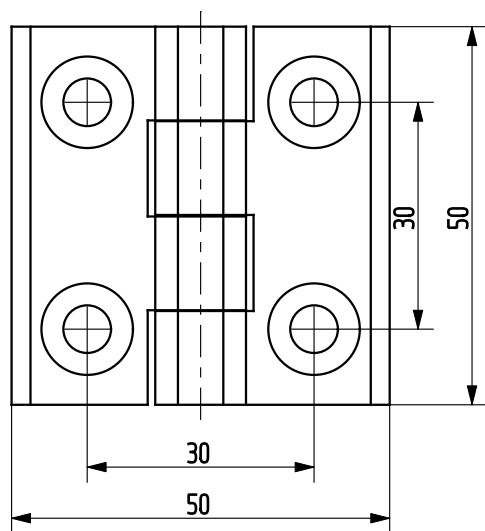

süllyesztés DIN 7991

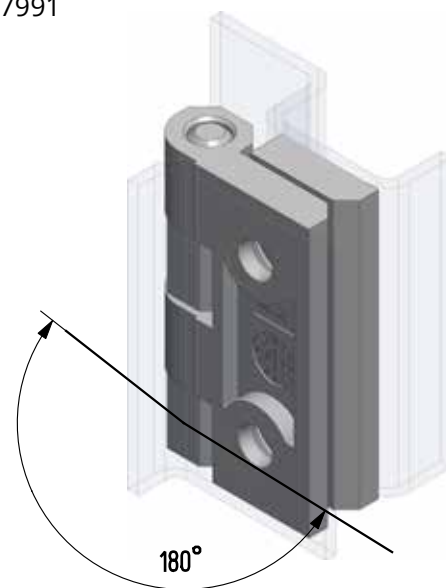
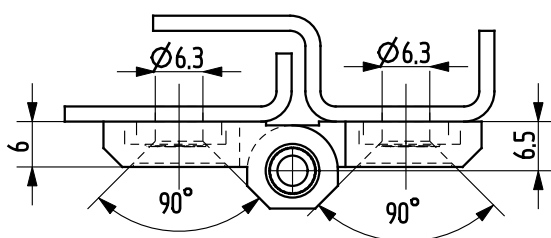

Termékszám	Alapanyag	Felületkezelés
90KO-KZS012-11	1.4571	elektropolír

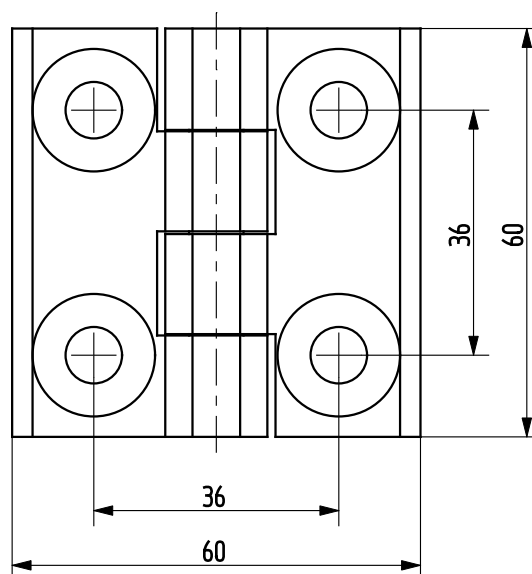
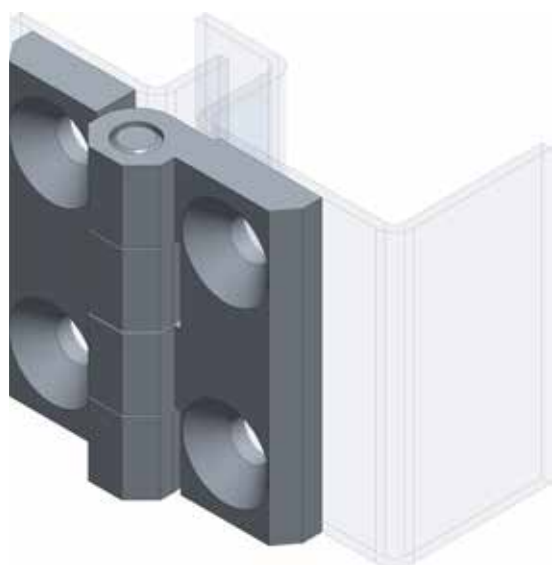

süllyesztés DIN 7991

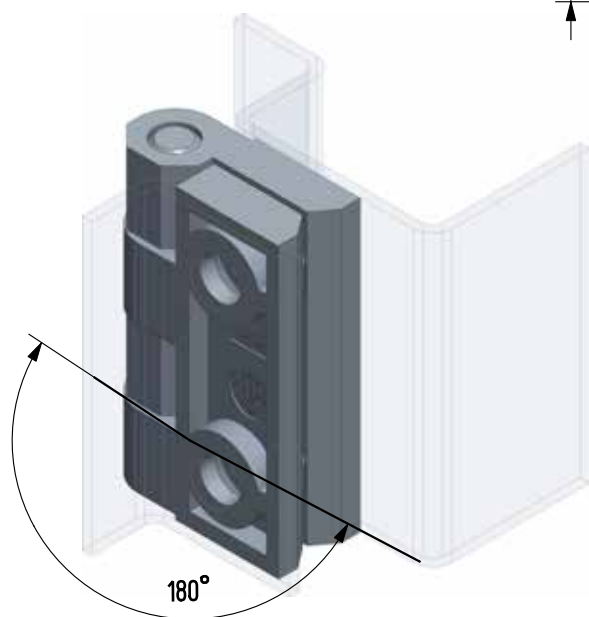
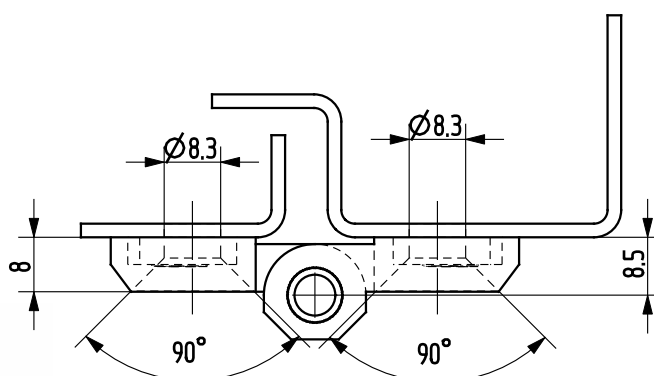

Termékszám	Alapanyag	Felületkezelés
90ZA-KZS031-04	cinköntvény	krómozva

Zsanérok

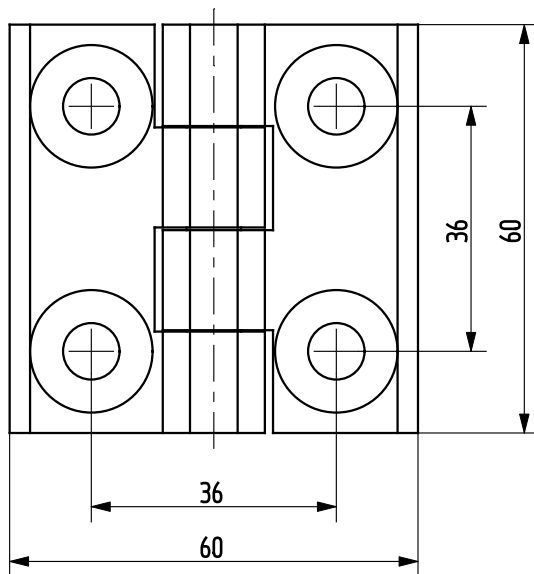

süllyesztés DIN 7991

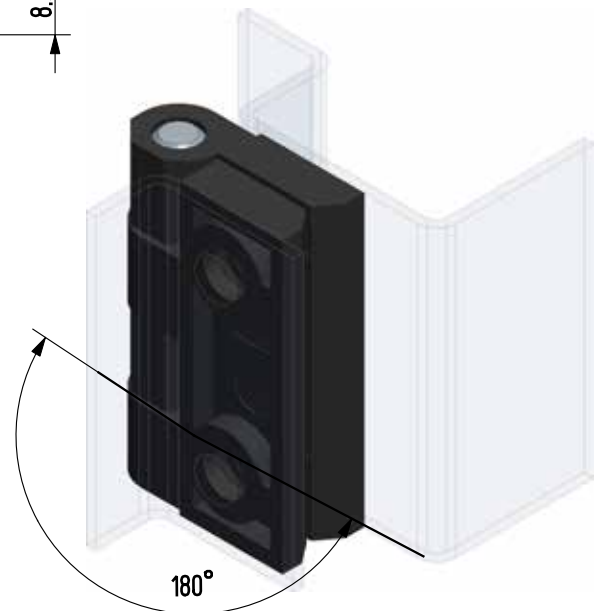
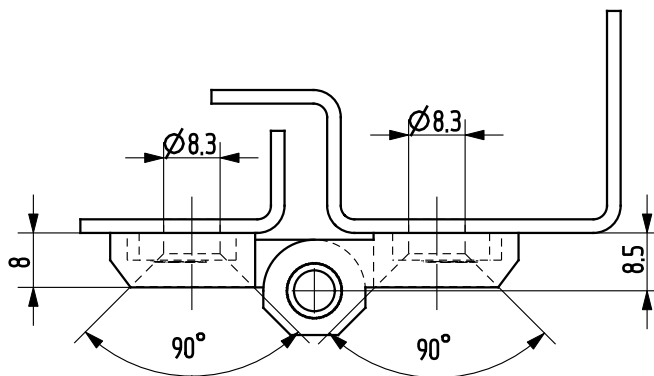

Termékszám
90ZA-KZS031-06

Alapanyag
cinköntvény

Felületkezelés
fekete porszórt

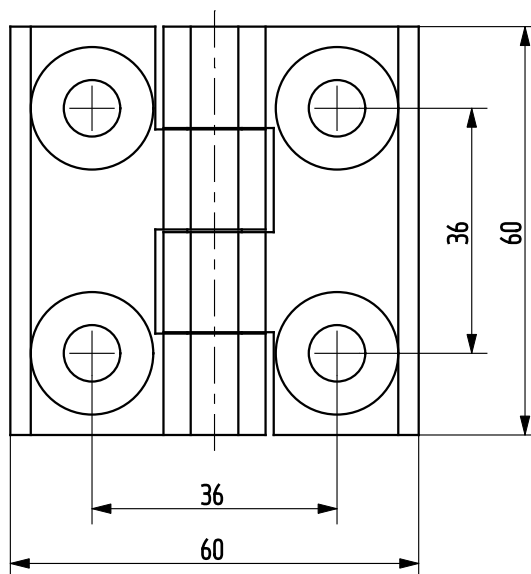
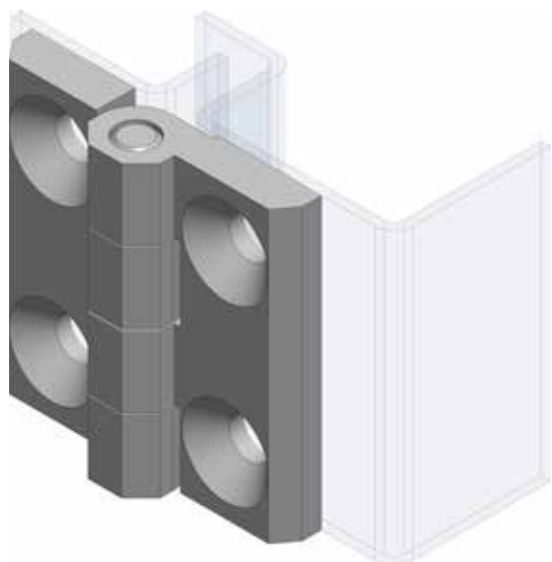

süllyesztés DIN 7991

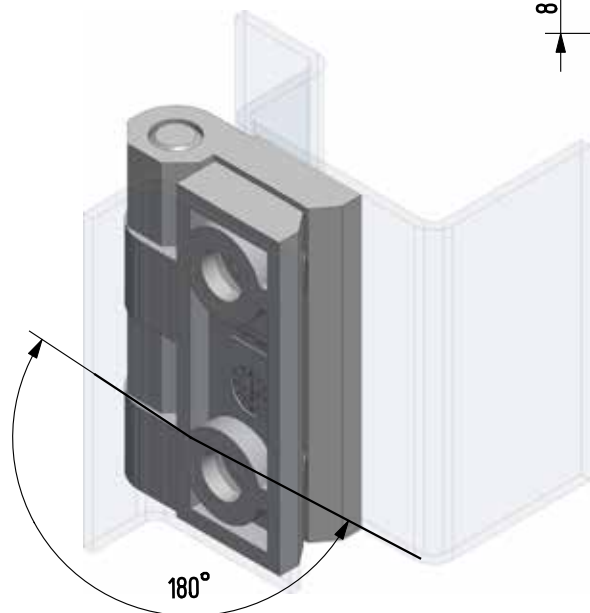
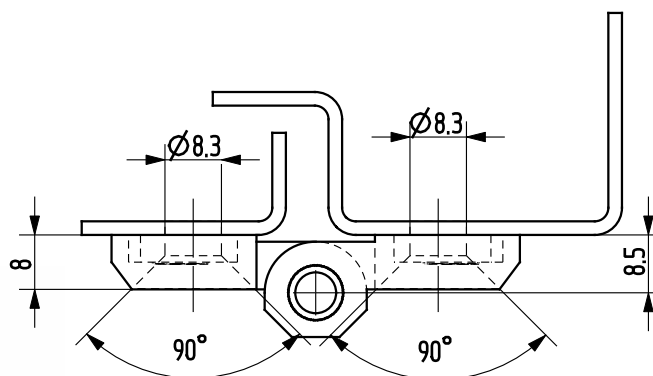

Termékszám	Alapanyag	Felületkezelés
90KO-KZS005-11	1.4571	elektropolír

Zsanérok

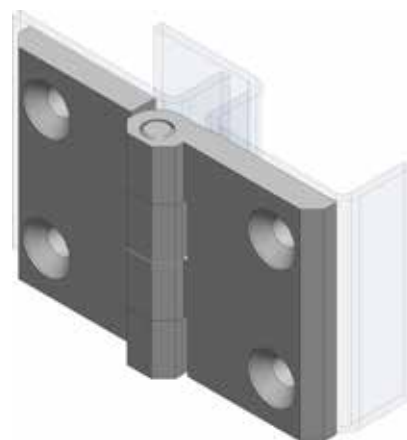
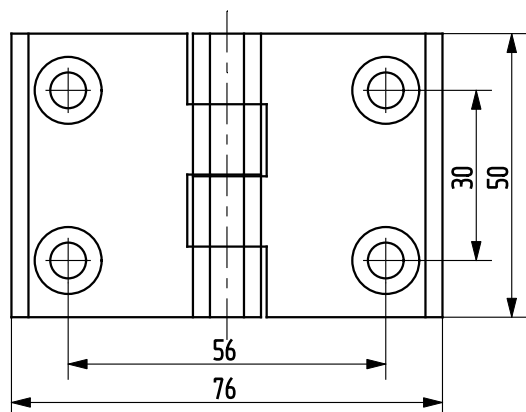

süllyesztés DIN 7991

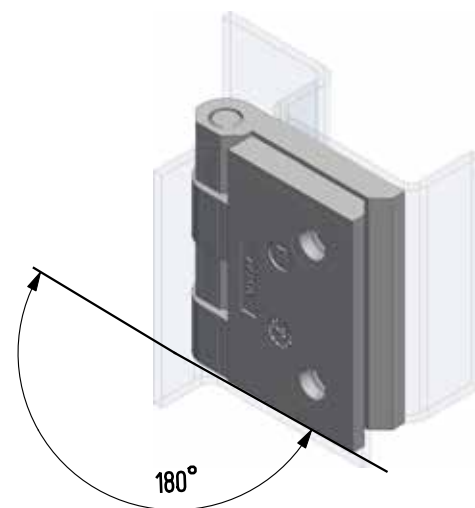
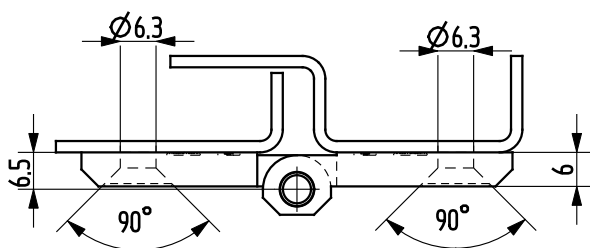

Termékszám	Alapanyag	Felületkezelés
90KO-KZS023-11	1.4571	elektropolír

Zsanérok

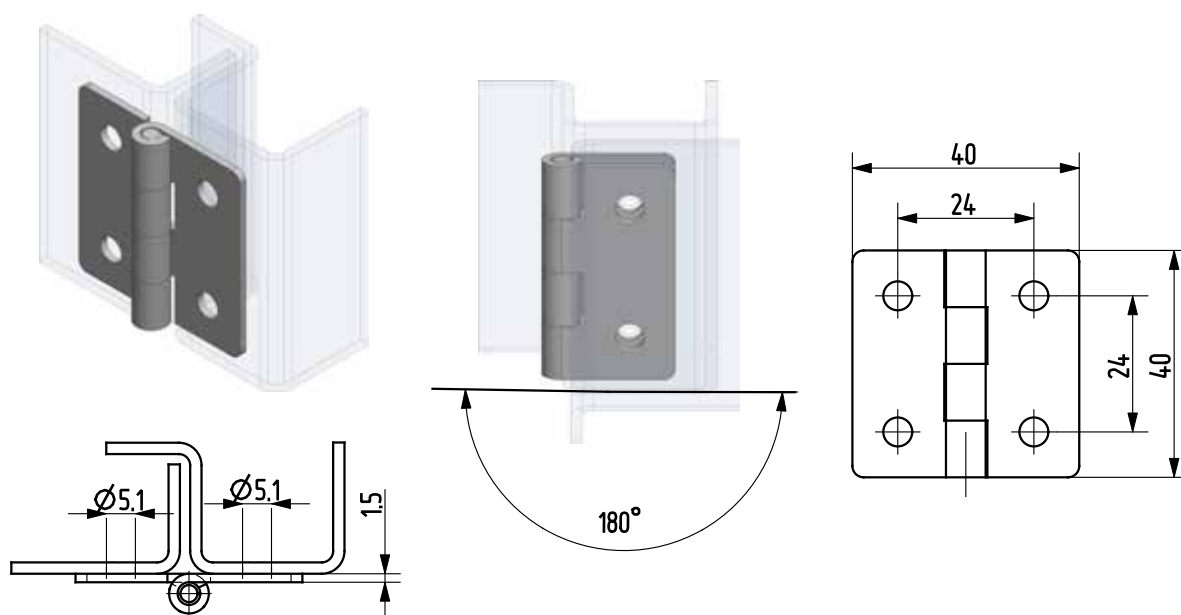

Termékszám	Alapanyag	Felületkezelés
90KO-KZS062-00	1.4301	-
90KO-KZS086-00	1.4571	-

Hegeszthető kivitel

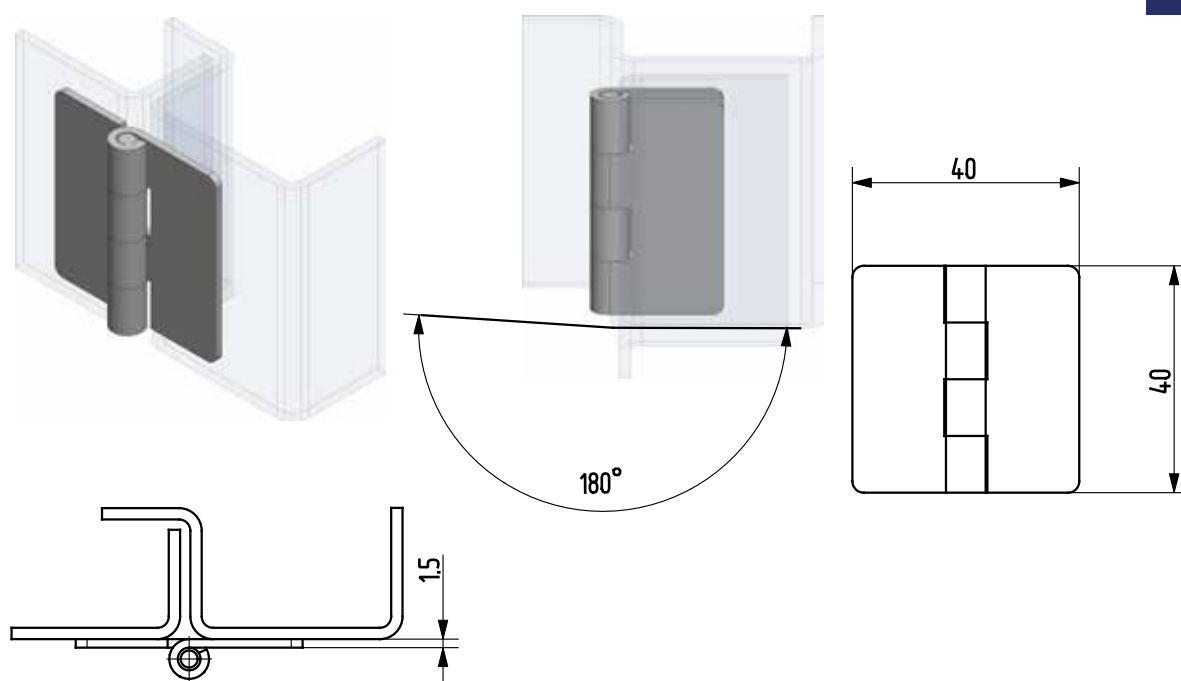

Termékszám	Alapanyag	Felületkezelés
90KO-KZS088-00	1.4301	-
90KO-KZS089-00	1.4571	-

Zsanérok

Hegeszthető kivitel

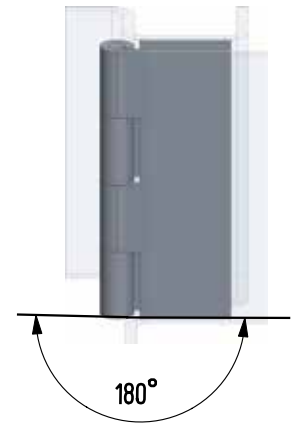
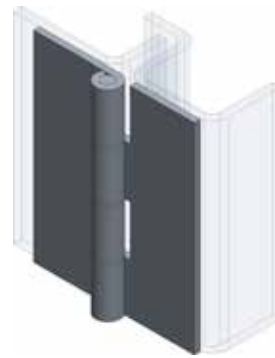
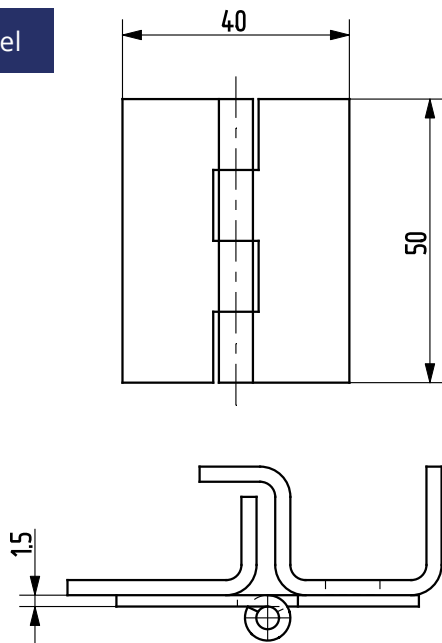

Termékszám	Alapanyag	Felületkezelés
90ST-KZS039-00	ST	-

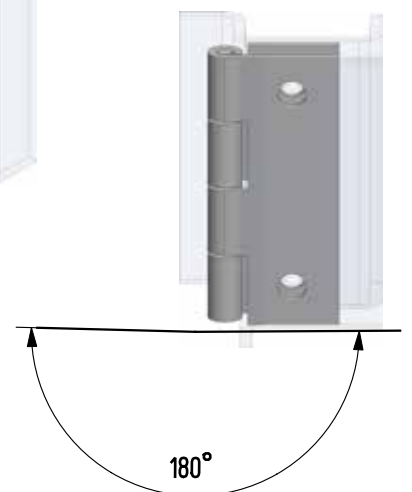
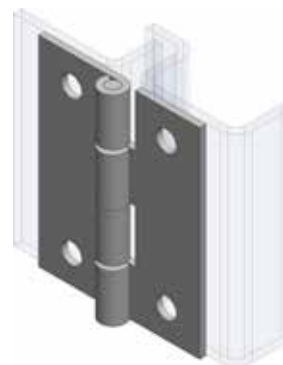
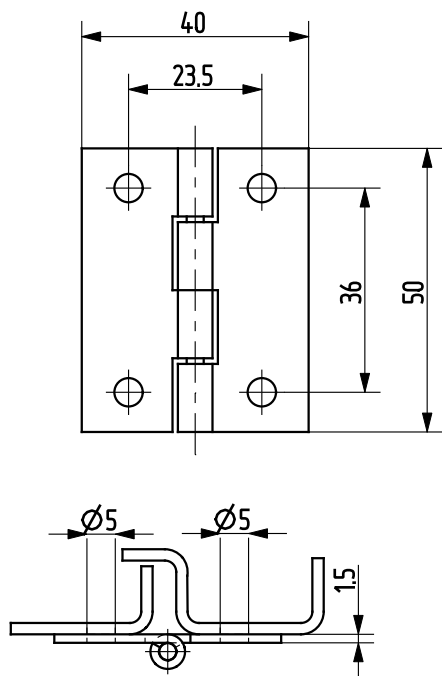

Termékszám	Alapanyag	Felületkezelés
90KO-KZS074-00	1.4571	-
90KO-KZS087-00	1.4301	-

Zsanérok

Hegeszthető kivitel

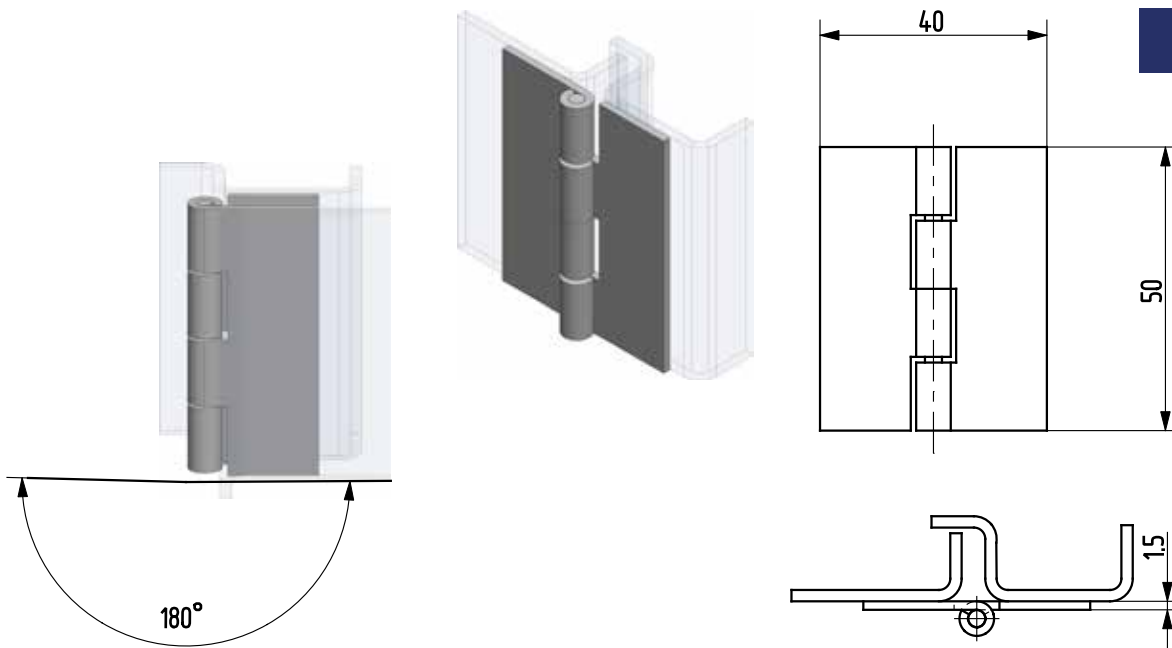

Termékszám	Alapanyag	Felületkezelés
90KO-KZS090-00	1.4301	-
90KO-KZS091-00	1.4571	-

Hegeszthető kivitel megegyezik a **90ST-KZS039-00** termékkel!

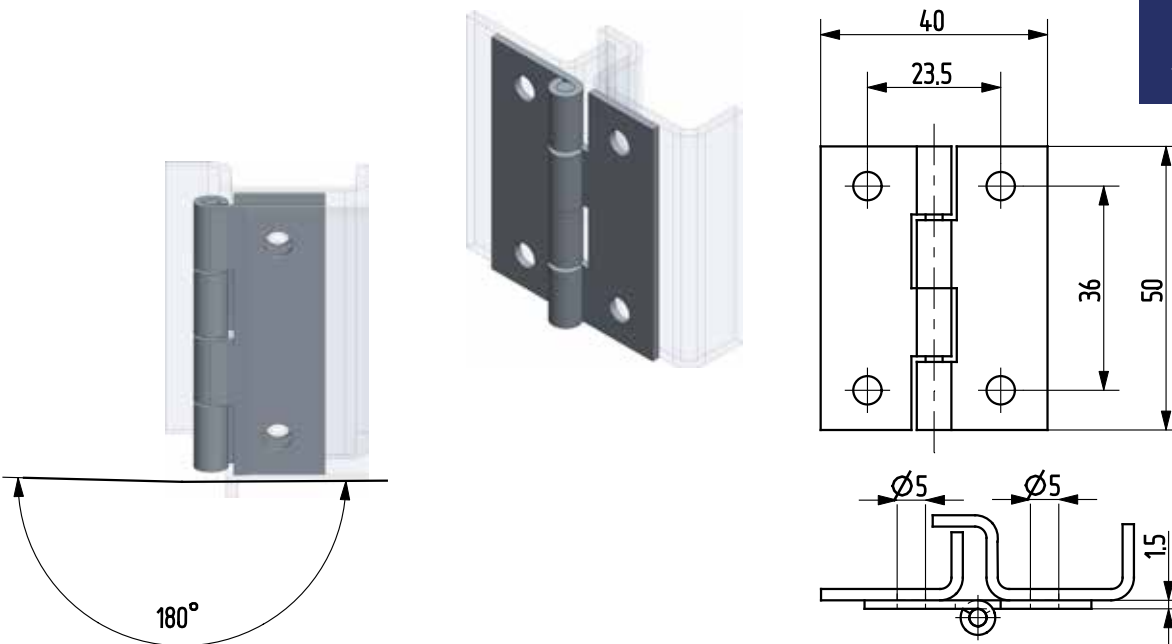

Termékszám	Alapanyag	Felületkezelés
90ST-KZS036-01	ST	horganyozva

Zsanérok



Kiemelhető lemez zsanérok

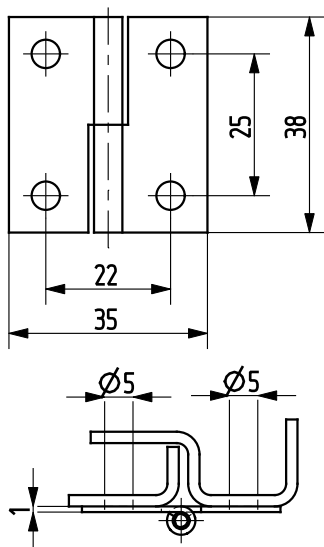

A képen a jobbos típus látható!
(Balos típus a jobbos tükörképe)

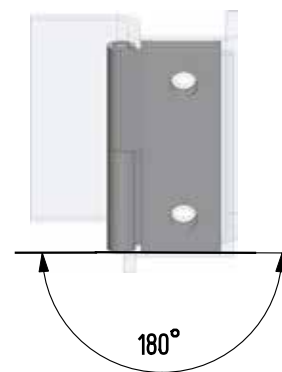

Termékszám	Alapanyag	Felületkezelés	Verzió
90KO-KZS080-00	1.4301	-	jobbos
90KO-KZS092-00	1.4571	-	jobbos
90KO-KZS079-00	1.4301	-	balos
90KO-KZS095-00	1.4571	-	balos

Hegeszthető kivitel

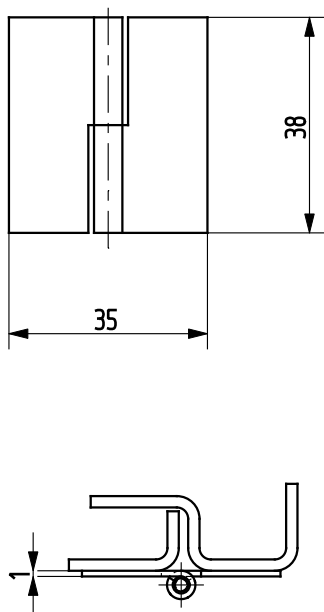

A képen a jobbos típus látható!
(Balos típus a jobbos tükörképe)

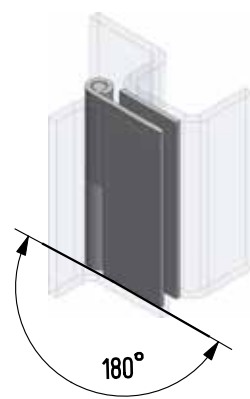

Termékszám	Alapanyag	Felületkezelés	Verzió
90KO-KZS093-00	1.4301	-	jobbos
90KO-KZS094-00	1.4571	-	jobbos
90KO-KZS096-00	1.4301	-	balos
90KO-KZS097-00	1.4571	-	balos

A képen a jobbos típus látható!
(Balos típus a jobbos tükörképe)

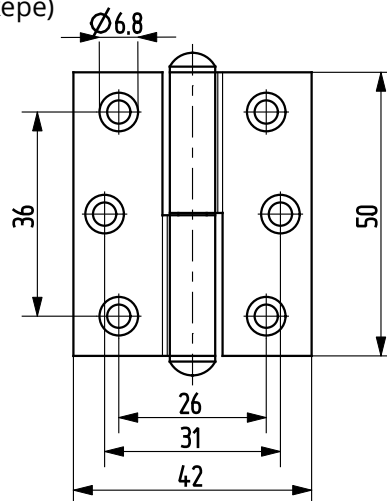
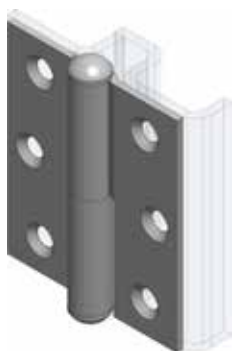
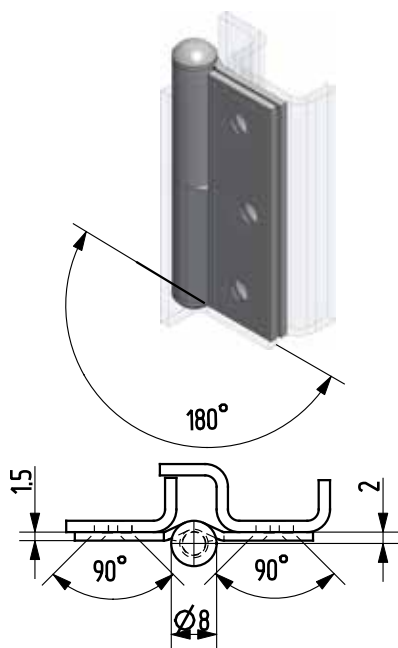

Termékszám	Alapanyag	Felületkezelés	Verzió
90KO-KZS078-00	1.4301	-	jobbos
90KO-KZS098-00	1.4571	-	jobbos
90KO-KZS077-00	1.4301	-	balos
90KO-KZS101-00	1.4571	-	balos

A képen a jobbos típus látható!
(Balos típus a jobbos tükörképe)

Hegeszthető kivitel

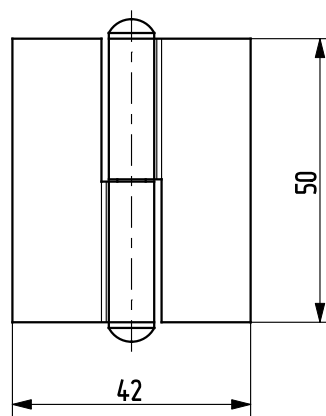
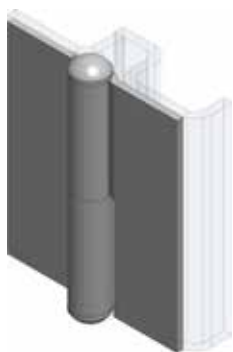
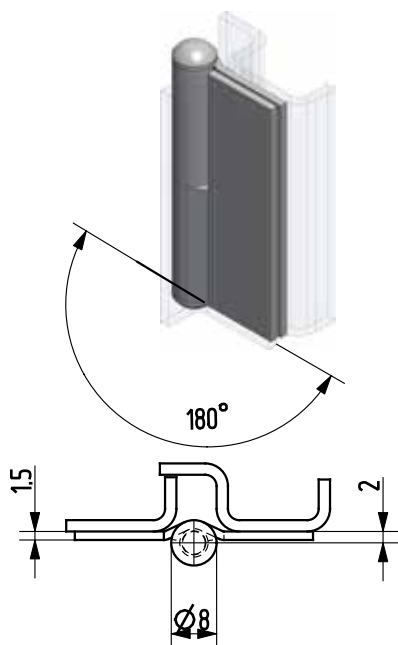

Termékszám	Alapanyag	Felületkezelés	Verzió
90KO-KZS099-00	1.4301	-	jobbos
90KO-KZS100-00	1.4571	-	jobbos
90KO-KZS102-00	1.4301	-	balos
90KO-KZS103-00	1.4571	-	balos

Zsanérok



Rugós zsanérok

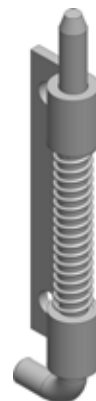
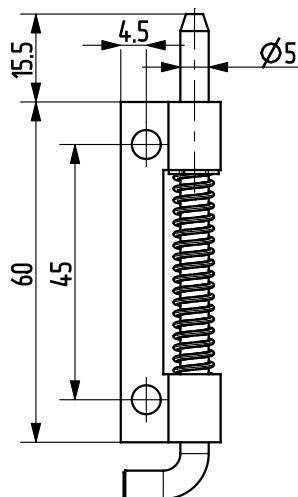
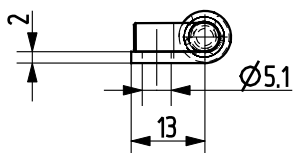

A képen a jobbos típus látható!
(Balos típus a jobbos tükörképe)

Termékszám	Alapanyag	Felületkezelés	Verzió
90KO-KZS056-00	1.4301	-	jobbos
90KO-KZS057-00	1.4301	-	balos

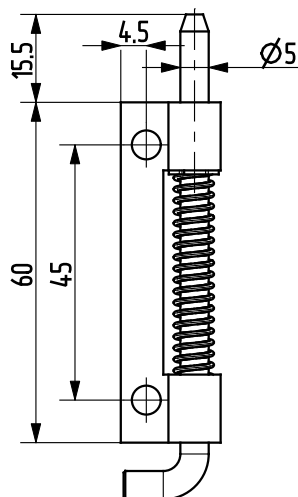
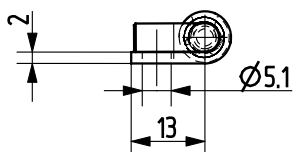

A képen a jobbos típus látható!
(Balos típus a jobbos tükörképe)

Termékszám	Alapanyag	Felületkezelés	Verzió
99ST-KZS003-01	ST	horganyozva	jobbos
99ST-KZS001-01	ST	horganyozva	balos

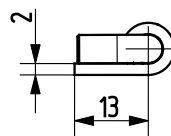
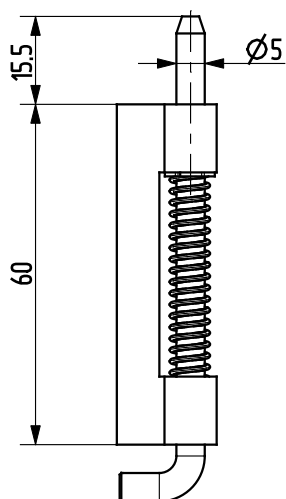

A képen a jobbos típus látható!
(Balos típus a jobbos tükörképe)

Termékszám	Alapanyag	Felületkezelés	Verzió
90ST-KZS020-01	ST	horganyozva	jobbos
90ST-KZS021-01	ST	horganyozva	balos

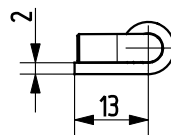
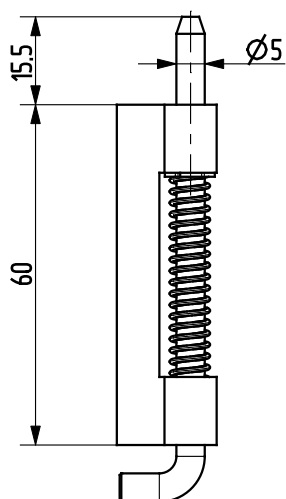
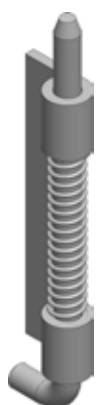

A képen a jobbos típus látható!
(Balos típus a jobbos tükörképe)

Termékszám	Alapanyag	Felületkezelés	Verzió
90KO-KZS058-00	1.4301	-	jobbos
90KO-KZS059-00	1.4301	-	balos



Zsanérok

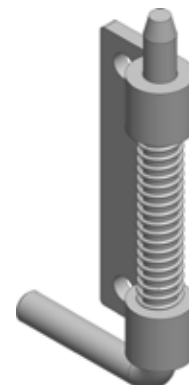
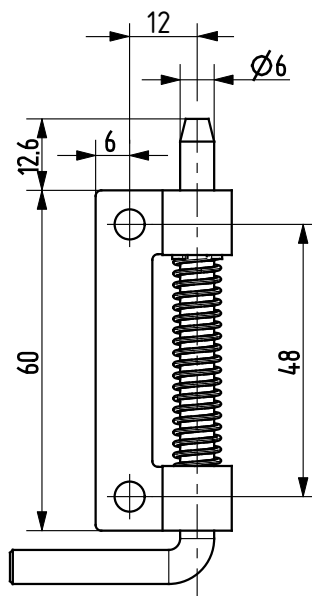
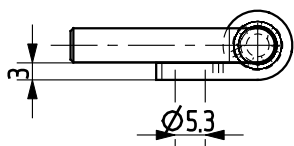

A képen a jobbos típus látható!
(Balos típus a jobbos tükörképe)

Termékszám	Alapanyag	Felületkezelés	Verzió
90KO-KZS076-00	1.4301	-	jobbos
90KO-KZS075-00	1.4301	-	balos

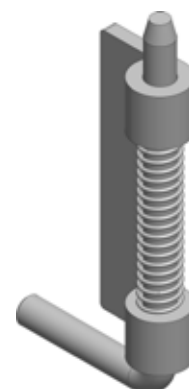
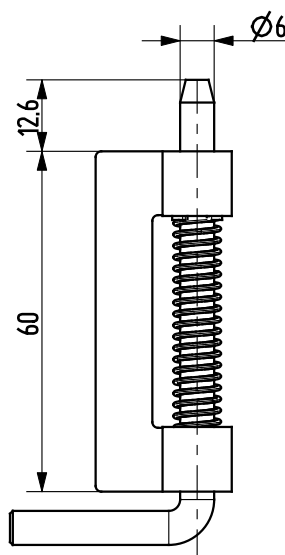
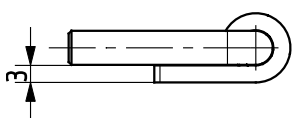

A képen a jobbos típus látható!
(Balos típus a jobbos tükörképe)

Termékszám	Alapanyag	Felületkezelés	Verzió
90KO-KZS104-00	1.4301	-	jobbos
90KO-KZS105-00	1.4301	-	balos

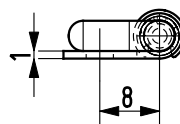
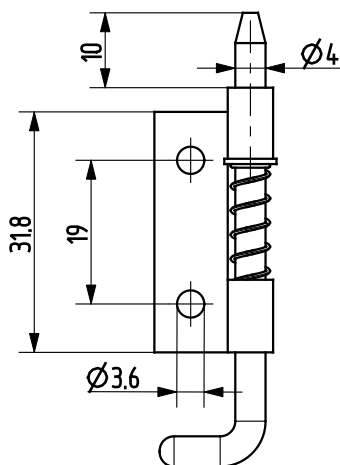

A képen a jobbos típus látható!
(Balos típus a jobbos tükörképe)

Termékszám	Alapanyag	Felületkezelés	Verzió
90ST-KZS031-01	ST	horganyozva	jobbos
90ST-KZS032-01	ST	horganyozva	balos

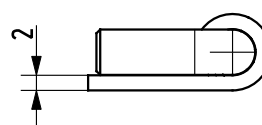
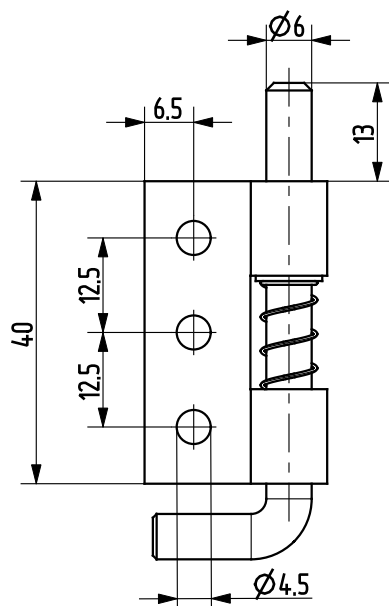

A képen a jobbos típus látható!
(Balos típus a jobbos tükörképe)

Termékszám	Alapanyag	Felületkezelés	Verzió
99ST-KZS019-01	ST	horganyozva	jobbos
99ST-KZS004-01	ST	horganyozva	balos



FOGANTYÚK

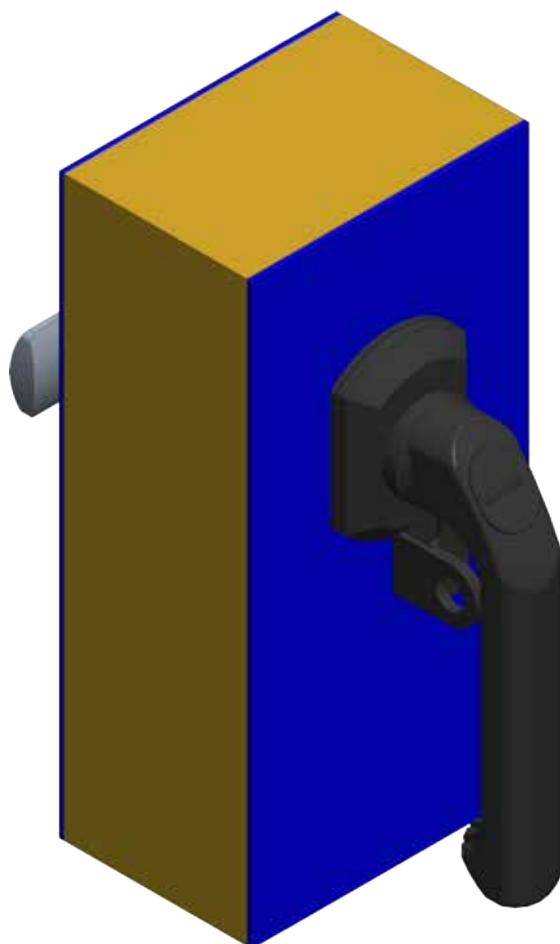

Fogantyúk és légtechnikai zárszerkezetek

Fogantyú

Megjegyzés:
*vevői logóval
rendelhető

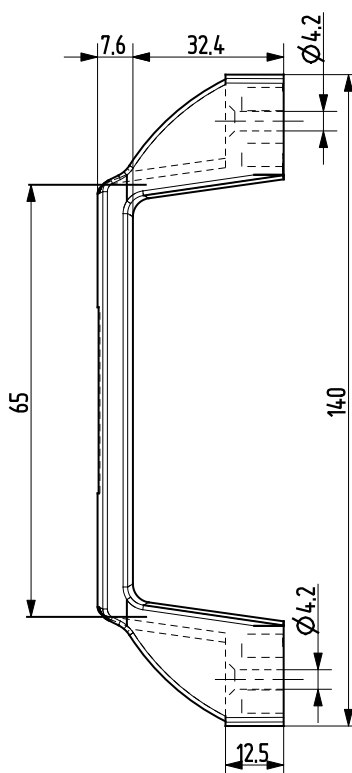
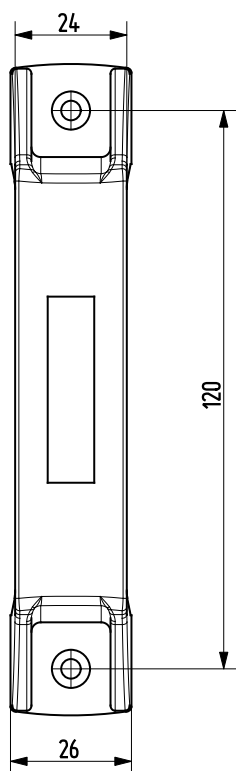

Termékszám Alapanyag
90PA-F002-00* poliamid

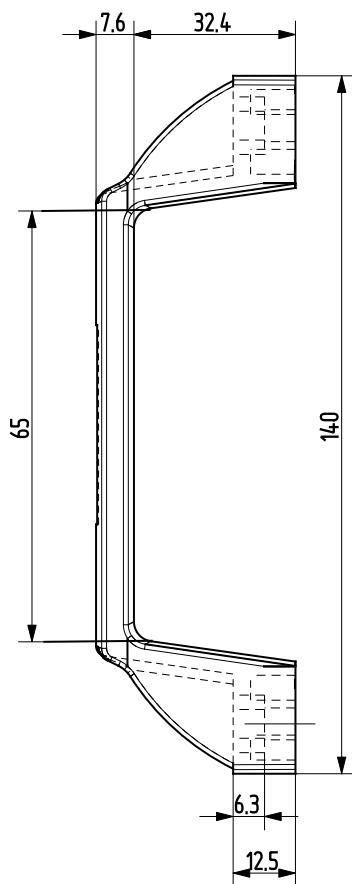
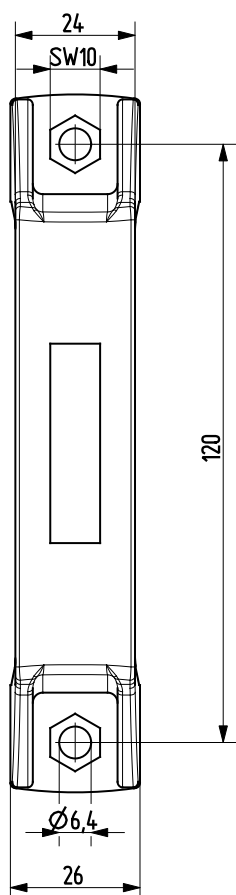

Termékszám Alapanyag
90PA-F003-00* poliamid

Fogantyúk és légtechnikai zárszerkezetek

Légtechnikai
zárszerkezet

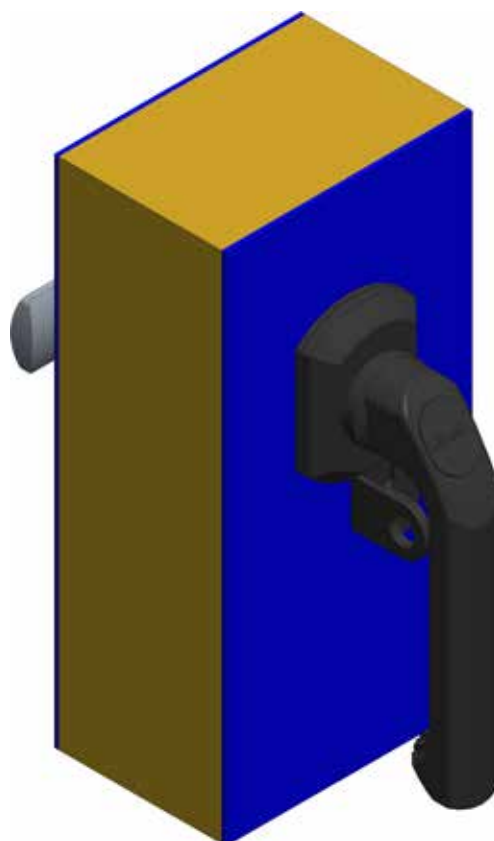

Fogantyúk és légtechnikai zárszerkezetek

Zárható
fogantyú

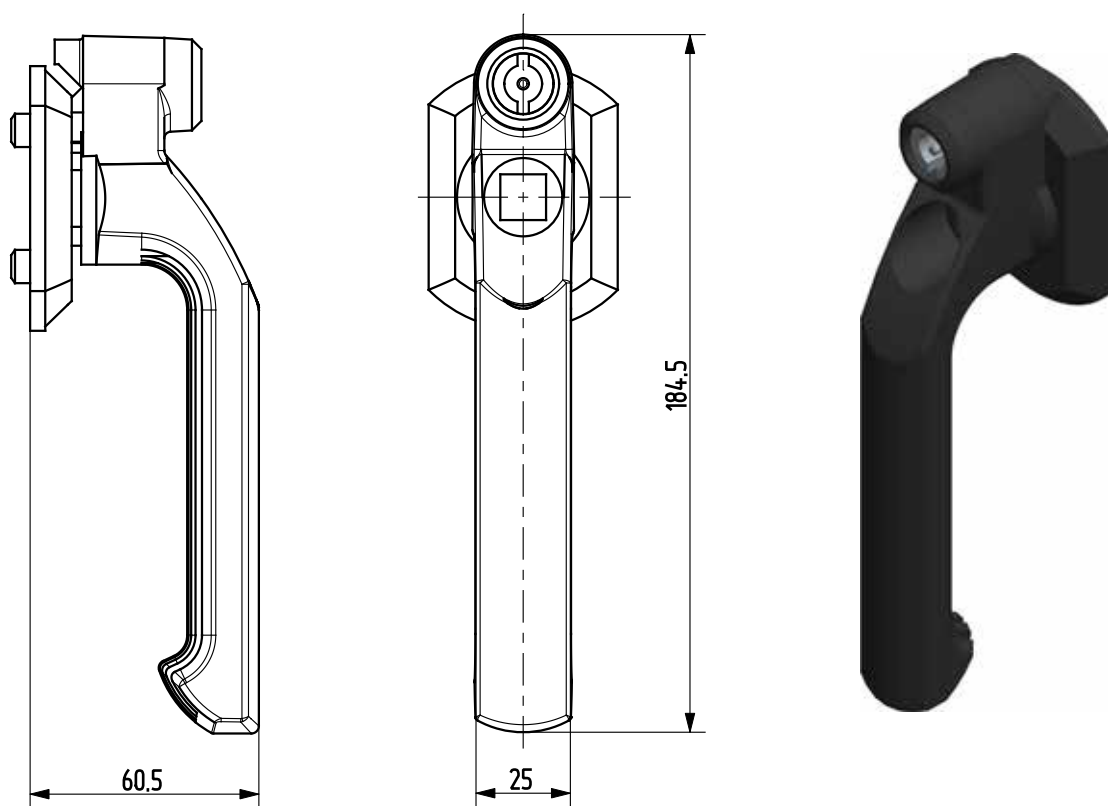

Termékszám	Alapanyag	Verzió
90PA-KF014-00	PA	jobbos
90PA-KF015-00	PA	balos



Megjegyzés:
*további
L=24.8 méretű
standard betétek
beépíthetők
(lásd ELA-B fejezet)

Zárbetét*	Cinköntvény	Felületkezelés	PA	Felületkezelés
3 mm duplatoll	90ZA-KB001-04	krómozva	90PA-KB001-00	-
3 mm duplatoll	90ZA-KB001-06	fekete porszórt	-	-
5 mm duplatoll	90ZA-KB003-04	krómozva	90PA-KB003-00	-
5 mm duplatoll	90ZA-KB003-06	fekete porszórt	-	-
7 mm háromszög	90ZA-KB011-04	krómozva	90PA-KB011-00	-
7 mm háromszög	90ZA-KB011-0-	fekete porszórt	-	-
8 mm háromszög	90ZA-KB012-04	krómozva	90PA-KB012-00	-
8 mm háromszög	90ZA-KB012-06	fekete porszórt	-	-
7 mm négyszög	90ZA-KB023-04	krómozva	90PA-KB023-00	-
7 mm négyszög	90ZA-KB023-06	fekete porszórt	-	-
8 mm négyszög	90ZA-KB008-04	krómozva	90PA-KB008-00	-
8 mm négyszög	90ZA-KB008-06	fekete porszórt	-	-

Fogantyúk és légtechnikai zárszerkezetek

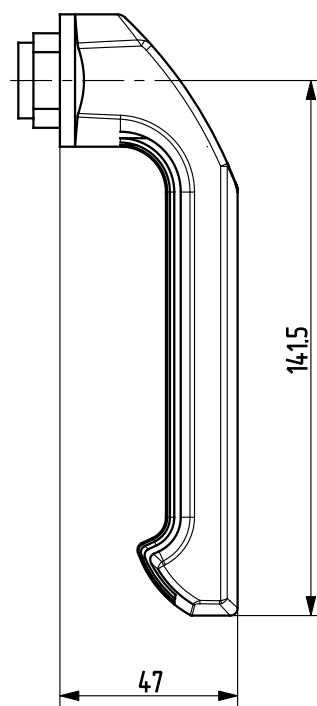
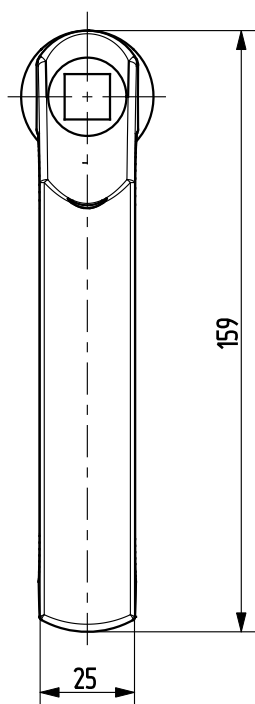

Termékszám

90PA-F016-00

Alapanyag

PA

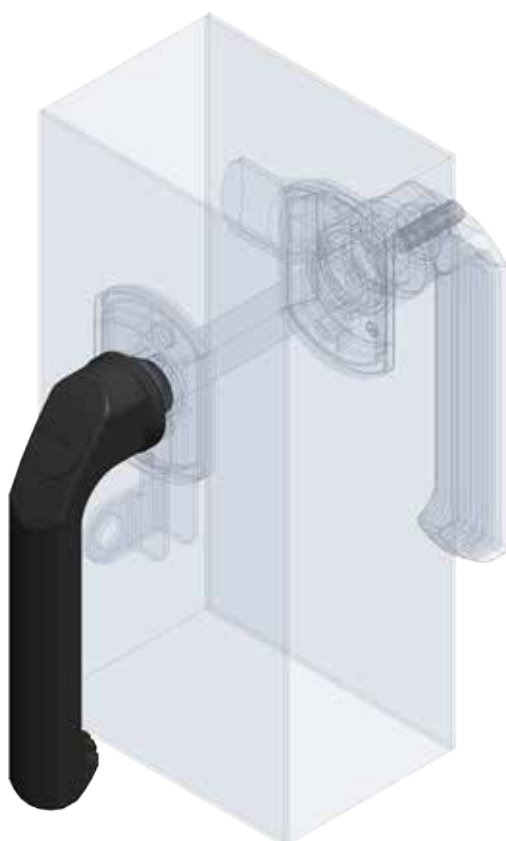

Fogantyúk és légtechnikai zárszerkezetek

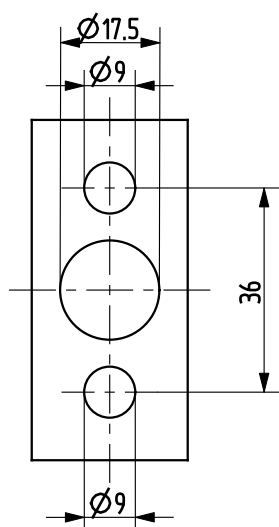

Ajtókibontás

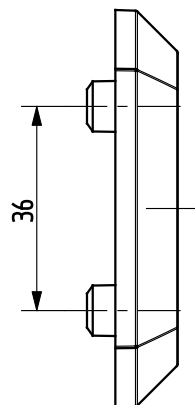

Termékszám

90PA-F017-00

Alapanyag

PA



Fogantyúk és légtechnikai zárszerkezetek

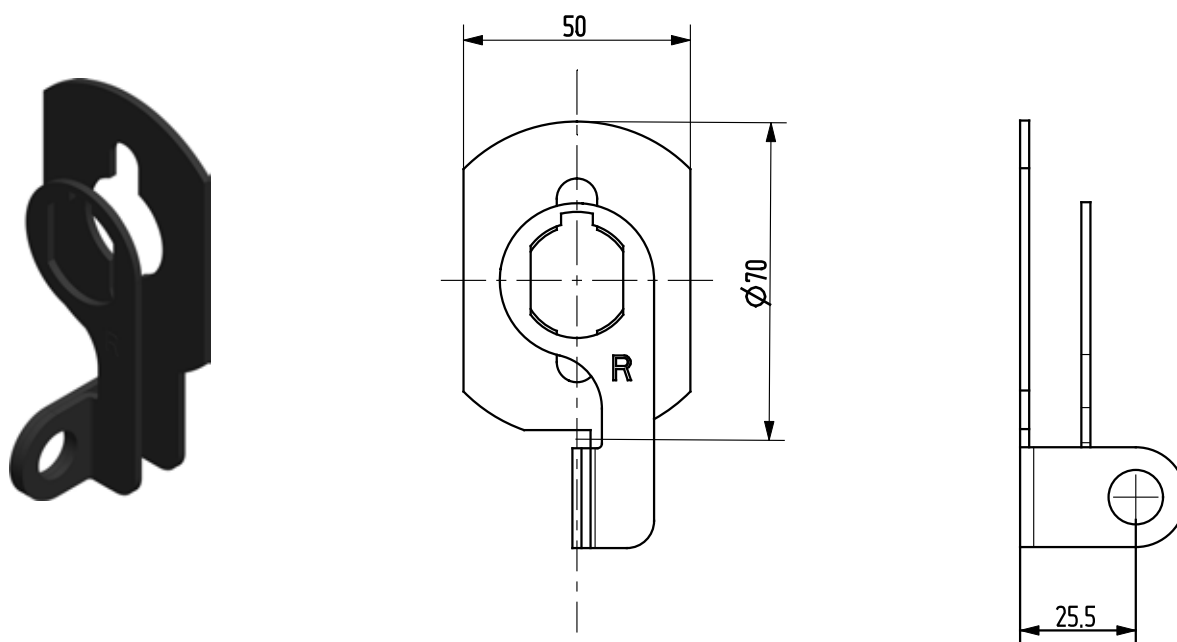

Termékszám	Alapanyag	Felületkezelés	Verzió
90ST-KHT004-06	ST	fekete porszórt	jobbos
90ST-KHT005-06	ST	fekete porszórt	balos

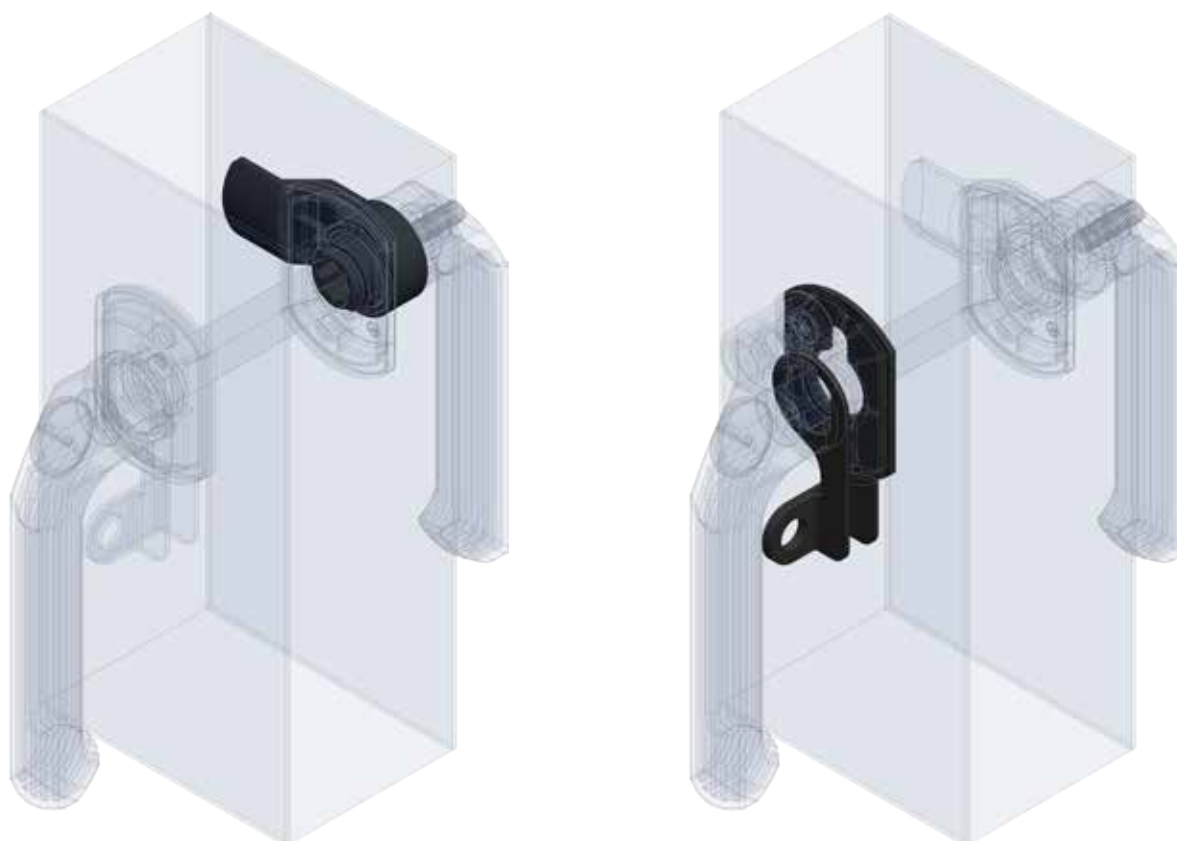

Fogantyúk és légtechnikai zárszerkezetek

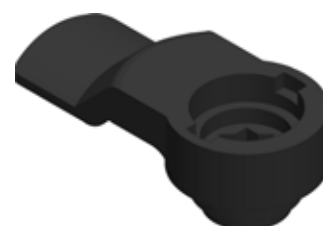
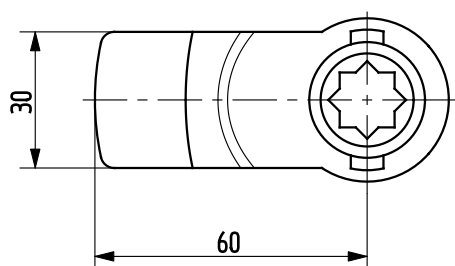
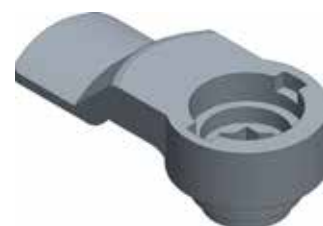
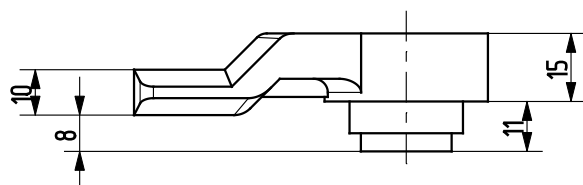

Termékszám	Alapanyag	Felületkezelés
90ZA-NY002-00	cinköntvény	-
90PA-NY025-00	PA	-

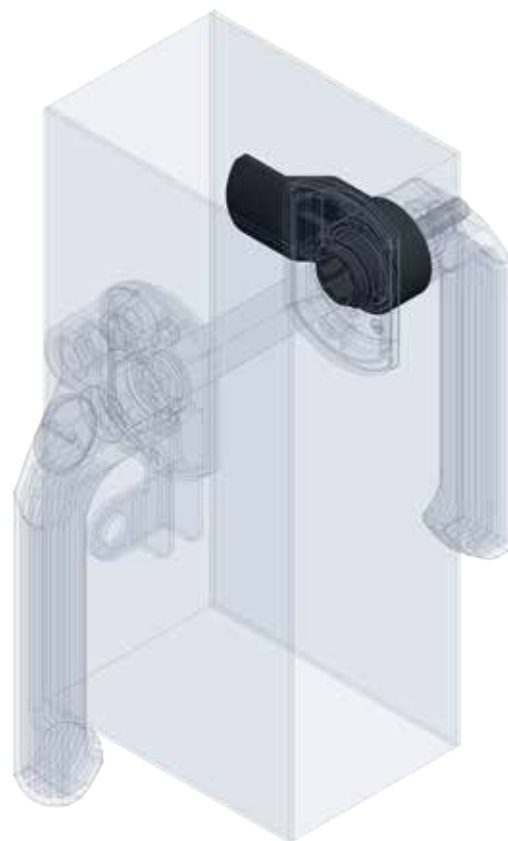

Fogantyúk és légtechnikai zárszerkezetek

Külső fogantyús
verzió

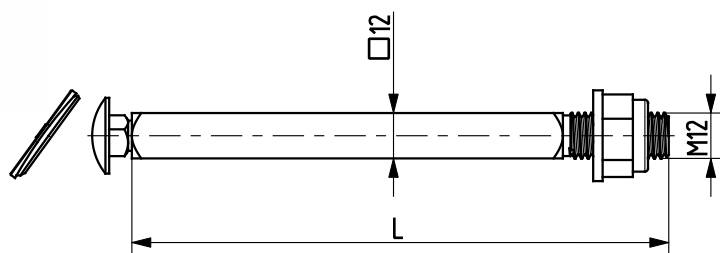

Ajtó vastagság	Tengely	Felületkezelés	L (mm)
20 mm	90ST-KHT006-01	horganyozva	82
30 mm	90ST-KHT007-01	horganyozva	92
40 mm	90ST-KHT008-01	horganyozva	102
50 mm	90ST-KHT009-01	horganyozva	112
60 mm	90ST-KHT010-01	horganyozva	122
80 mm	90ST-KHT011-01	horganyozva	142
100 mm	90ST-KHT012-01	horganyozva	162

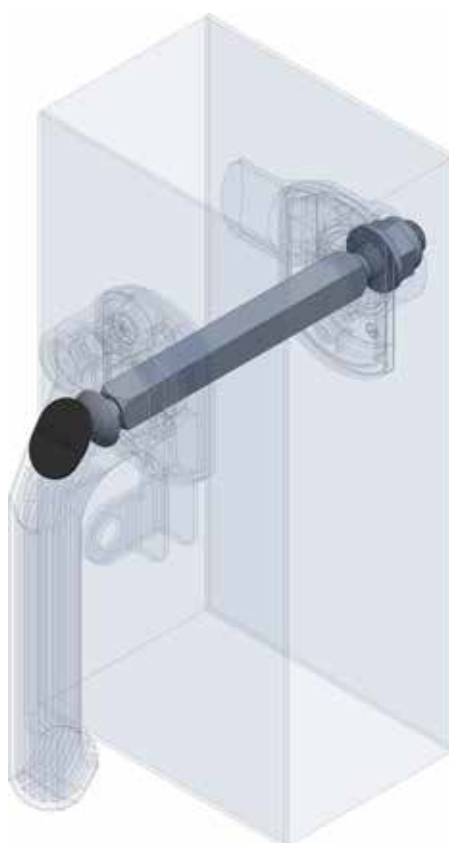
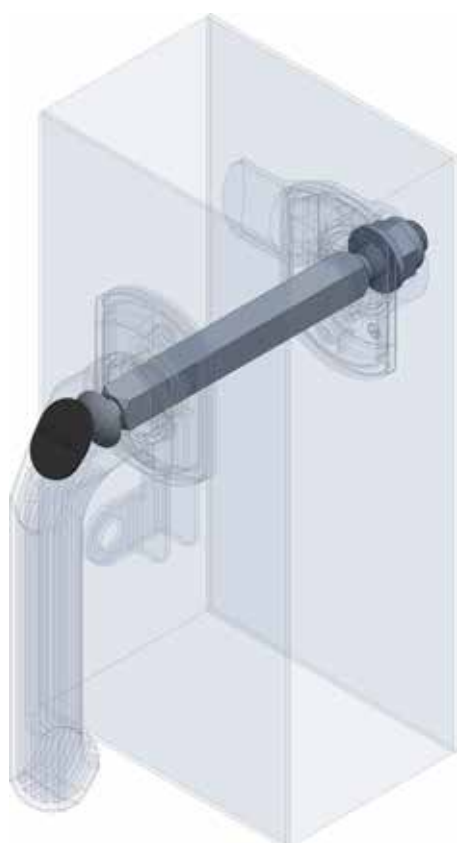

Fogantyúk és légtechnikai zárszerkezetek

Külső és belső
fogantyús verzió

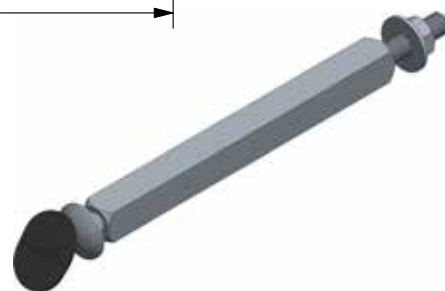
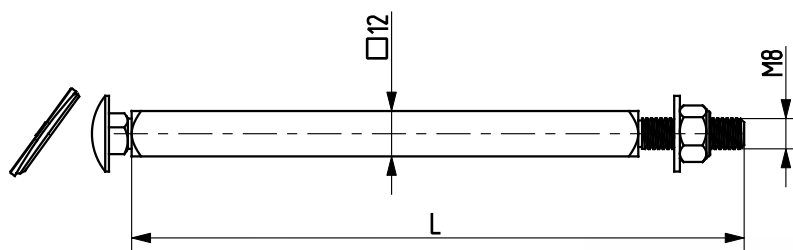

A belső karos verzió csak ezzel
a tengellyel szerelhető!

Ajtó vastagság	Tengely	Felületkezelés	L (mm)
20 mm	90ST-KHT013-01	horganyozva	102
30 mm	90ST-KHT014-01	horganyozva	112
40 mm	90ST-KHT015-01	horganyozva	122
50 mm	90ST-KHT016-01	horganyozva	132
60 mm	90ST-KHT017-01	horganyozva	142
80 mm	90ST-KHT018-01	horganyozva	162
100 mm	90ST-KHT019-01	horganyozva	182

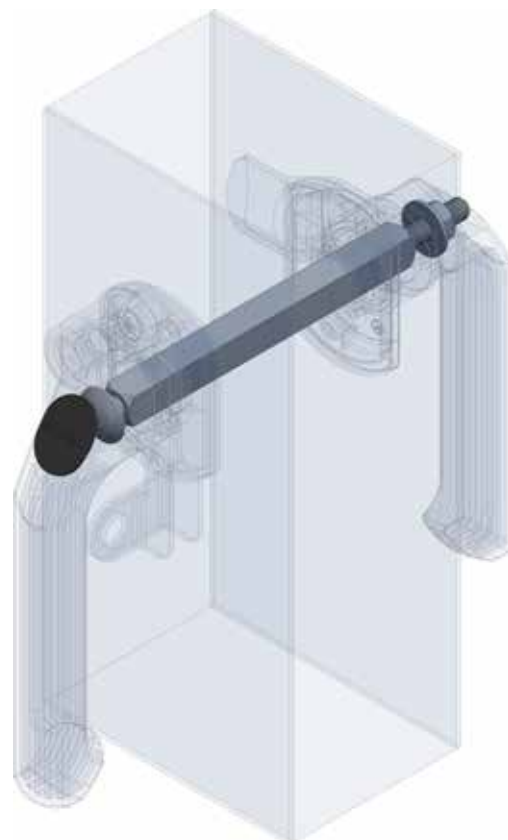
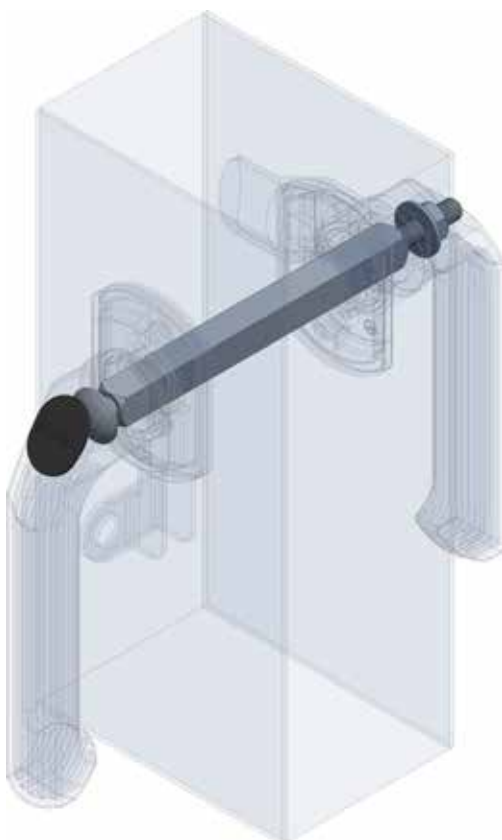



LENGŐKAROK



Lengőkarok

Kültéri lengőkarok

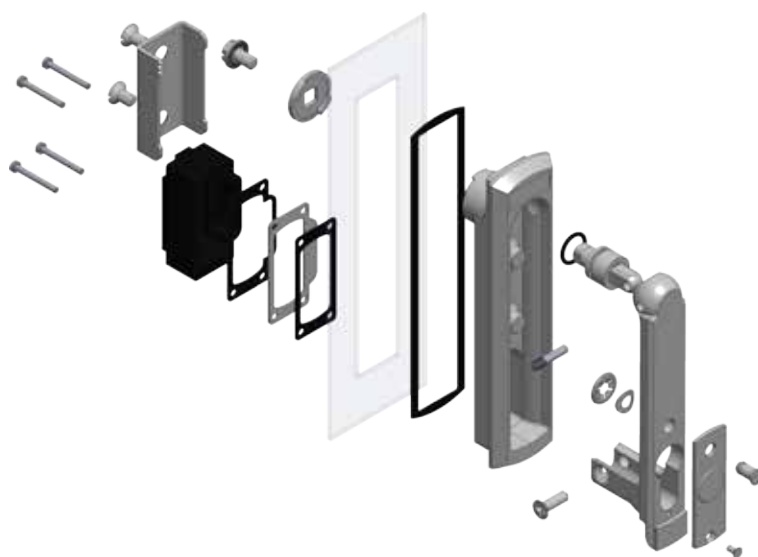

Lengőkarok

90KO-KF007-11 és
90KO-KF015-11
működési elve

Hajlított zárrúd szemmel és görgővel
az ELA-ZR-02 oldalon

Rúdvezető
az ELA-ZR-010 oldalon

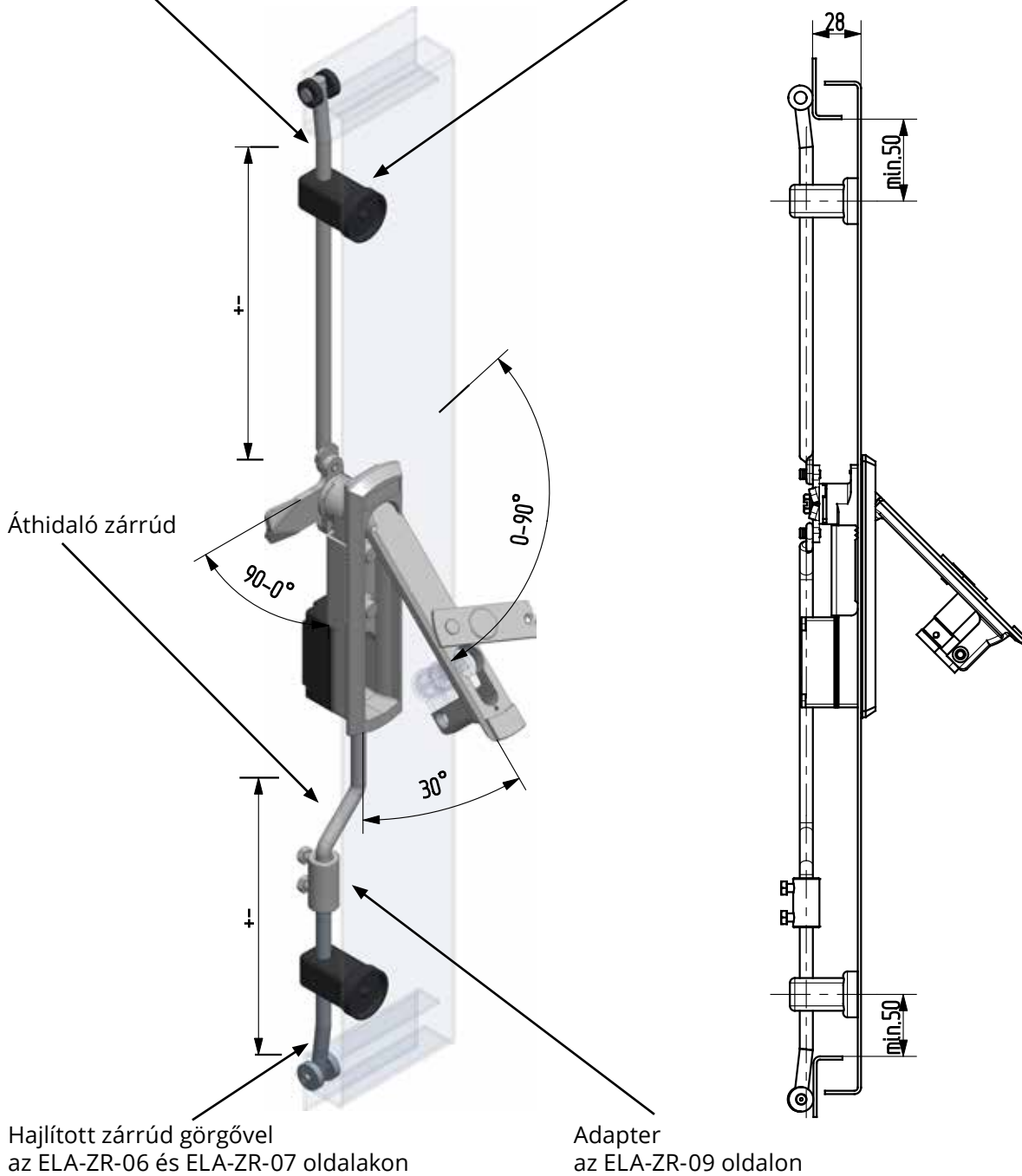

Hajlított zárrúd görgővel
az ELA-ZR-06 és ELA-ZR-07 oldalakon

Adapter
az ELA-ZR-09 oldalon

Termékszám	Áthidaló zárhíd Alapanyag	Felületkezelés
91KO-R056-00	1.4301	-
91ST-R056-01	ST	horganyozva

Lengőkarok

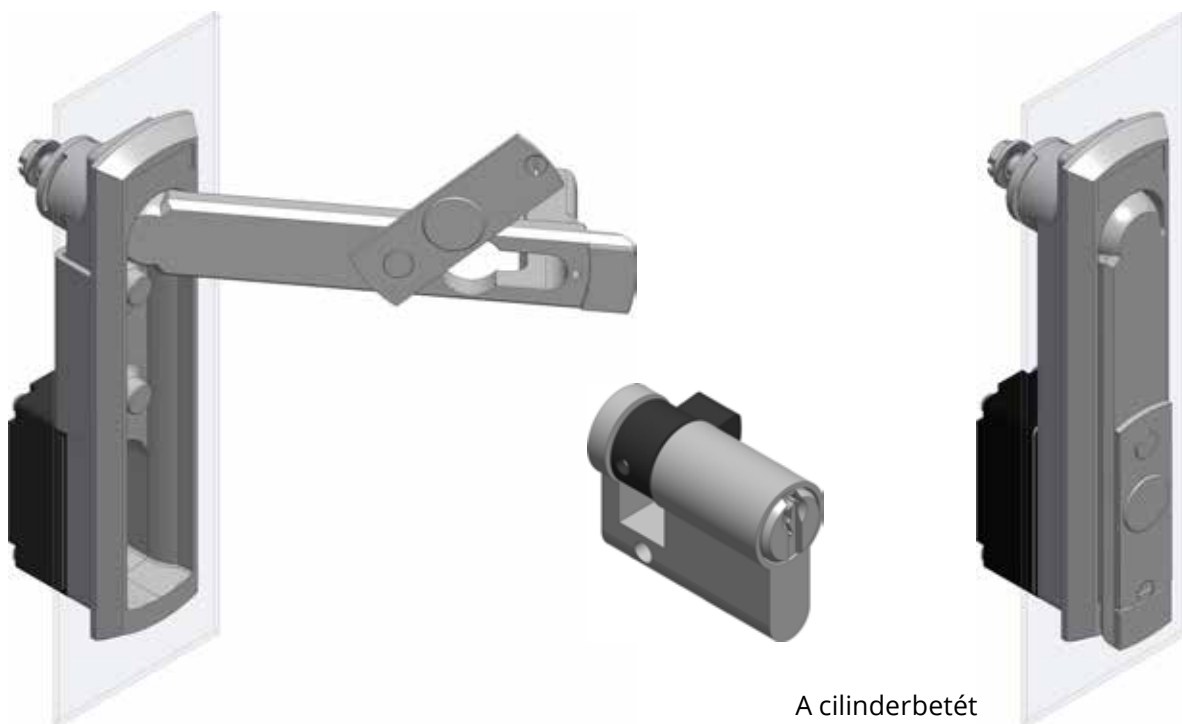

A cylinderbetét nem tartozék!

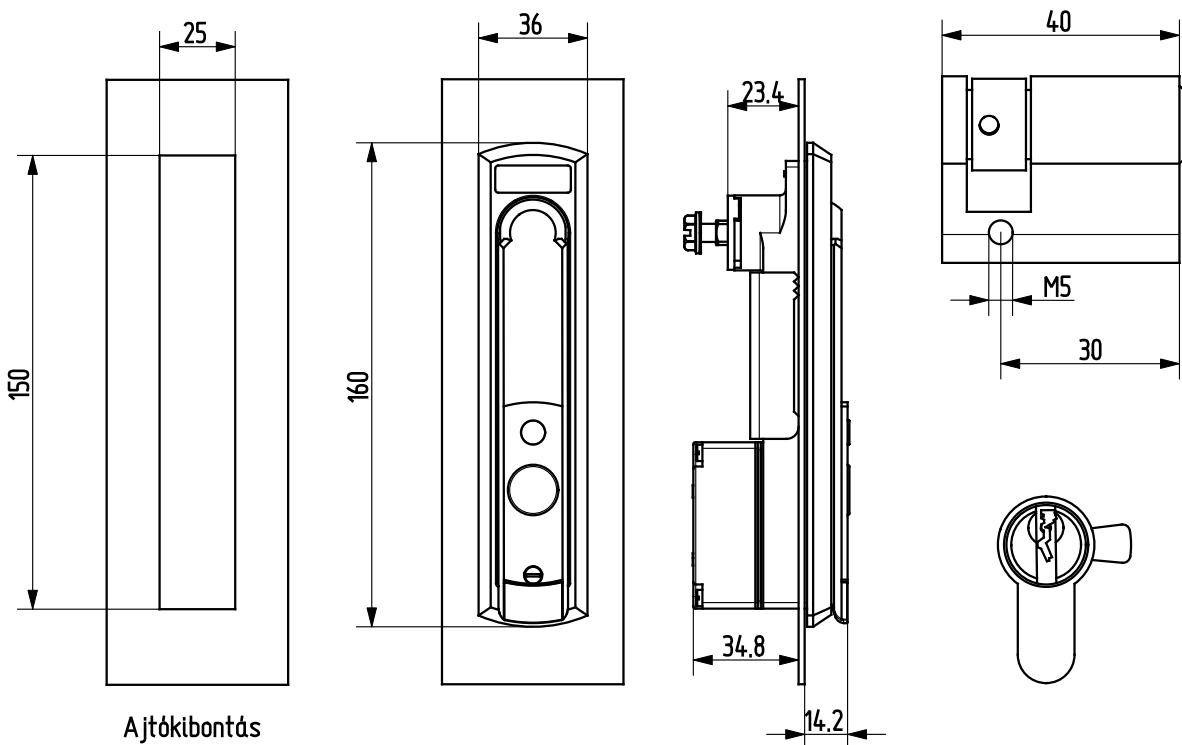

Ajtókibontás

Termékszám	Alapanyag	Felületkezelés
90KO-KF007-11	1.4571	elektropolír

Lengőkarok

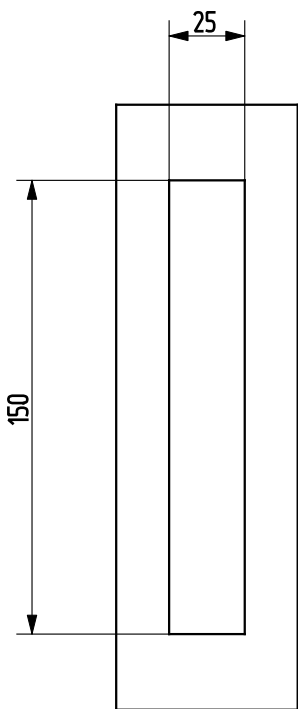
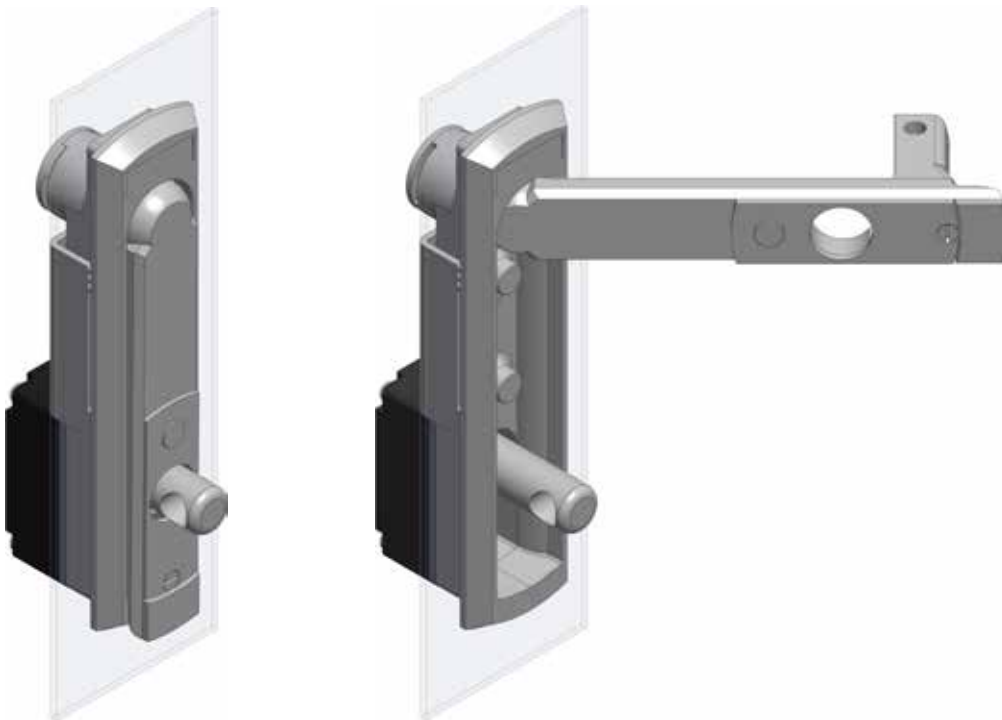

Ajtókibontás

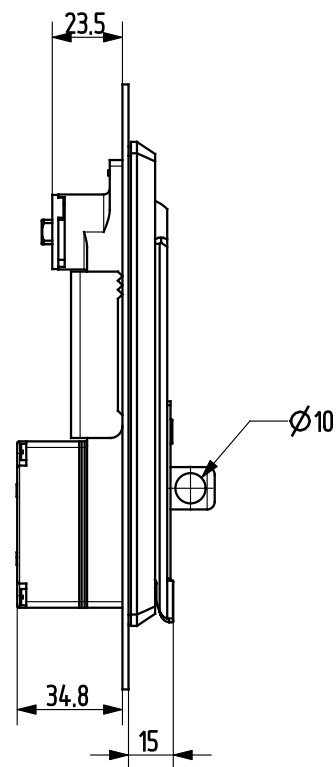
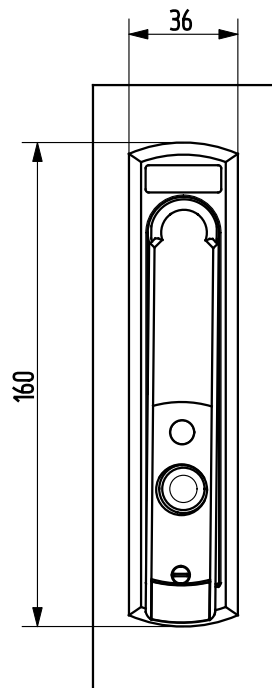

Termékszám	Alapanyag	Felületkezelés
90KO-KF015-11	1.4571	elektropolír

Lengőkarok

90ZA-KF002-06
és 91ZA-KF0002-06
működési elve

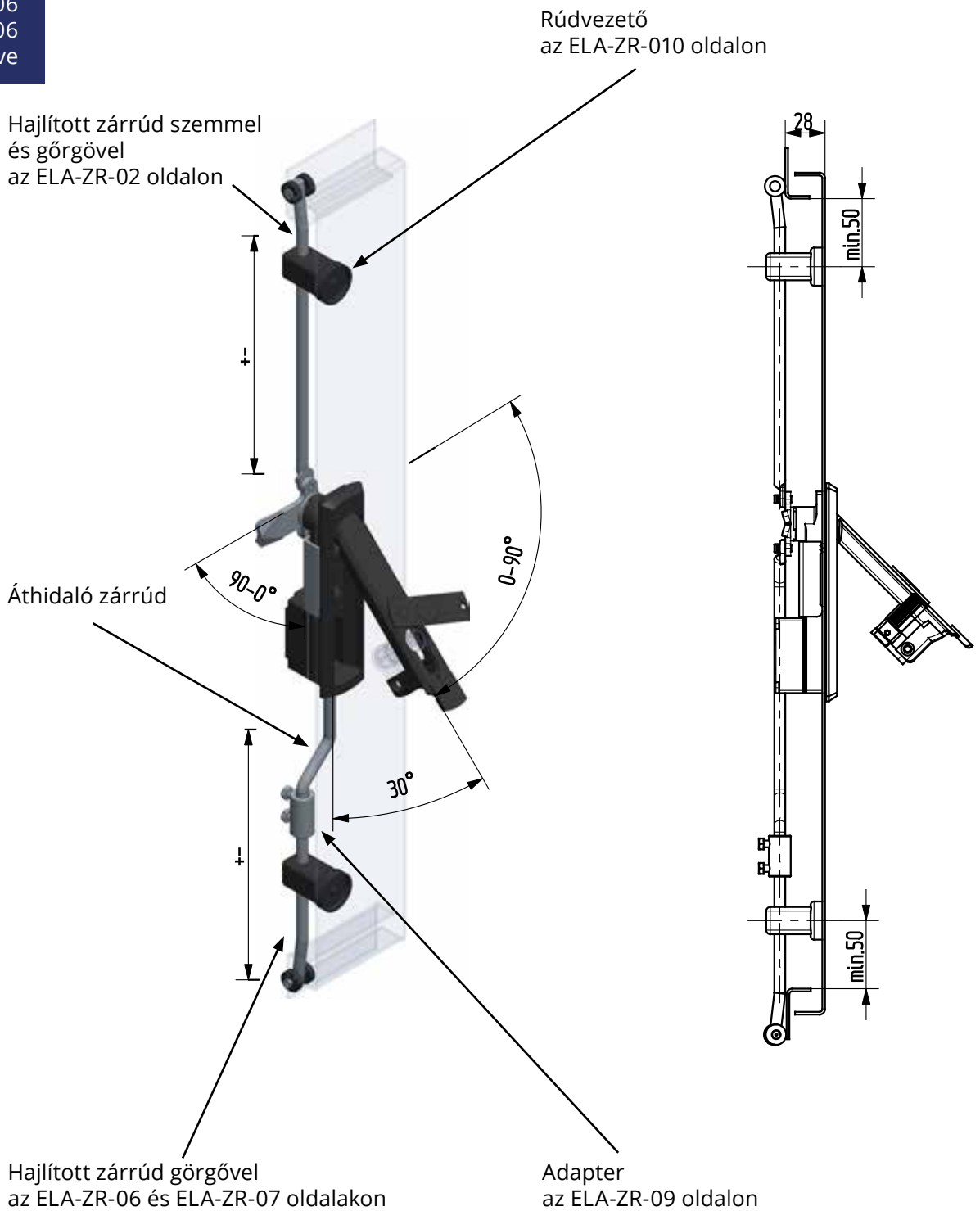

Termékszám	Áthidaló zárhíd		Felületkezelés
	Alapanyag		
91KO-R056-00	1.4301		-
91ST-R056-01	ST		horganyozva

Lengőkarok

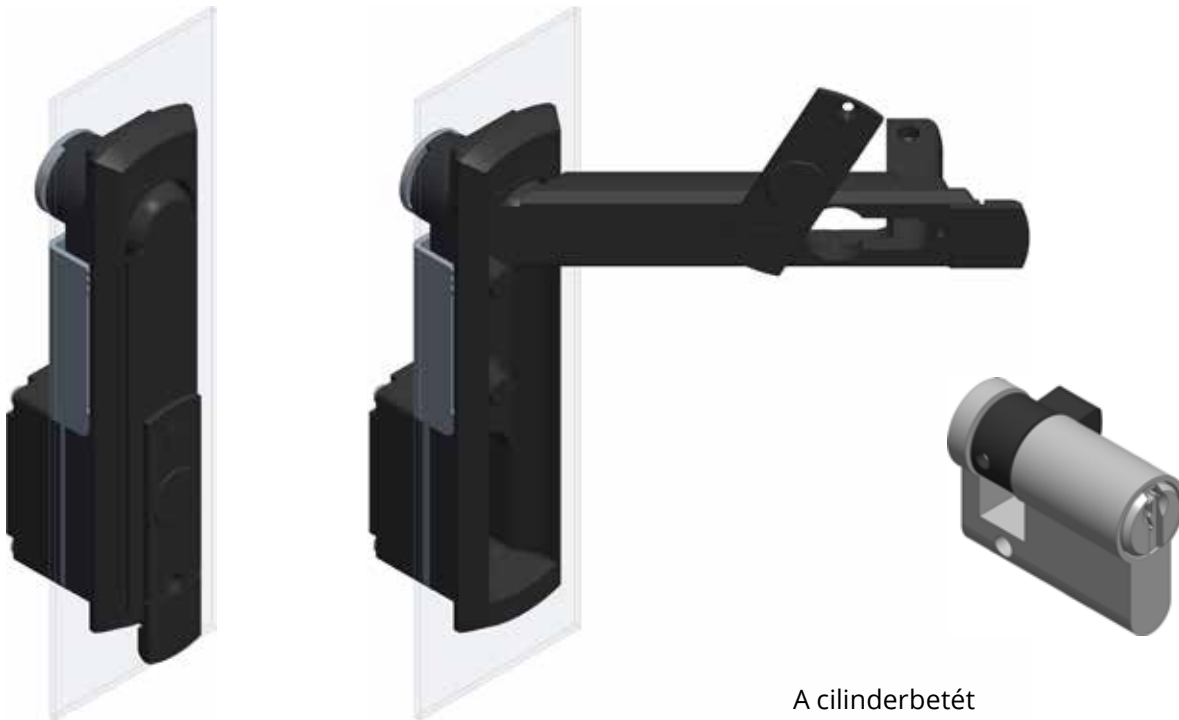

A cylinderbetét
nem tartozék!

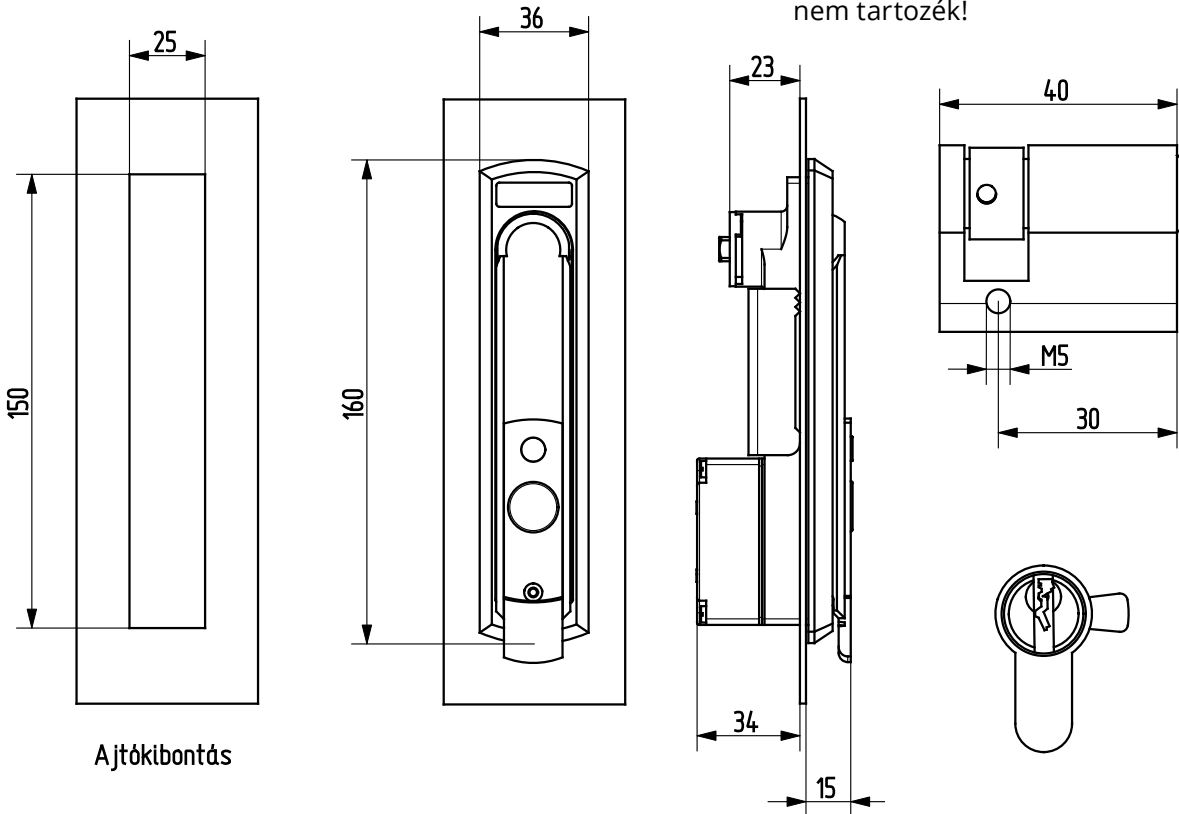

Ajtókibontás

Termékszám	Alapanyag	Felületkezelés
90ZA-KF002-06	cinköntvény	fekete porszórt

Lengőkarok

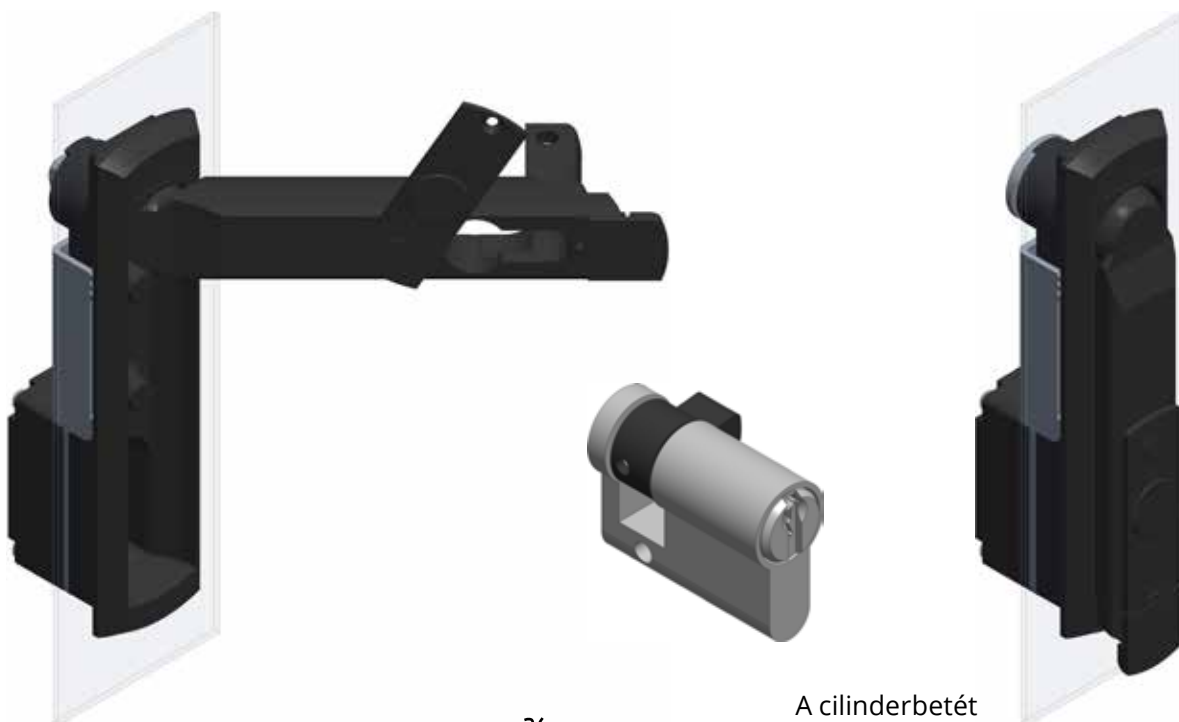

A cylinderbetét
nem tartozék!

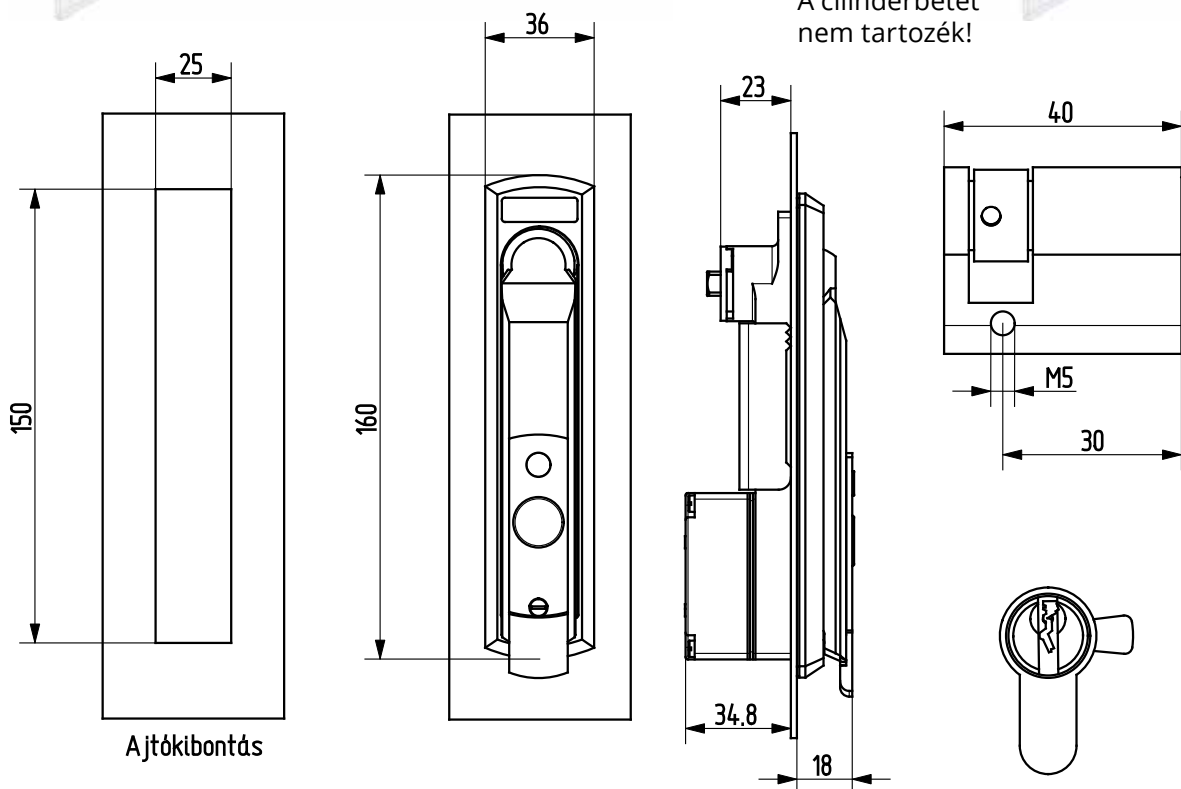

Termékszám	Alapanyag	Felületkezelés
91ZA-KF002-06	cinköntvény	fekete porszórt

Lengőkarok

90PA-KHT001-00
az ELA-L-013 oldalon

90PA-KHT004-00
az ELA-L-013 oldalon

Hajlított zárúdgörgővel
az ELA-ZR-02 oldalon

90ZA-KF012-06 és
90ZA-KF013-06
működési elve

Rúdvezető
az ELA-ZR-010 oldalon

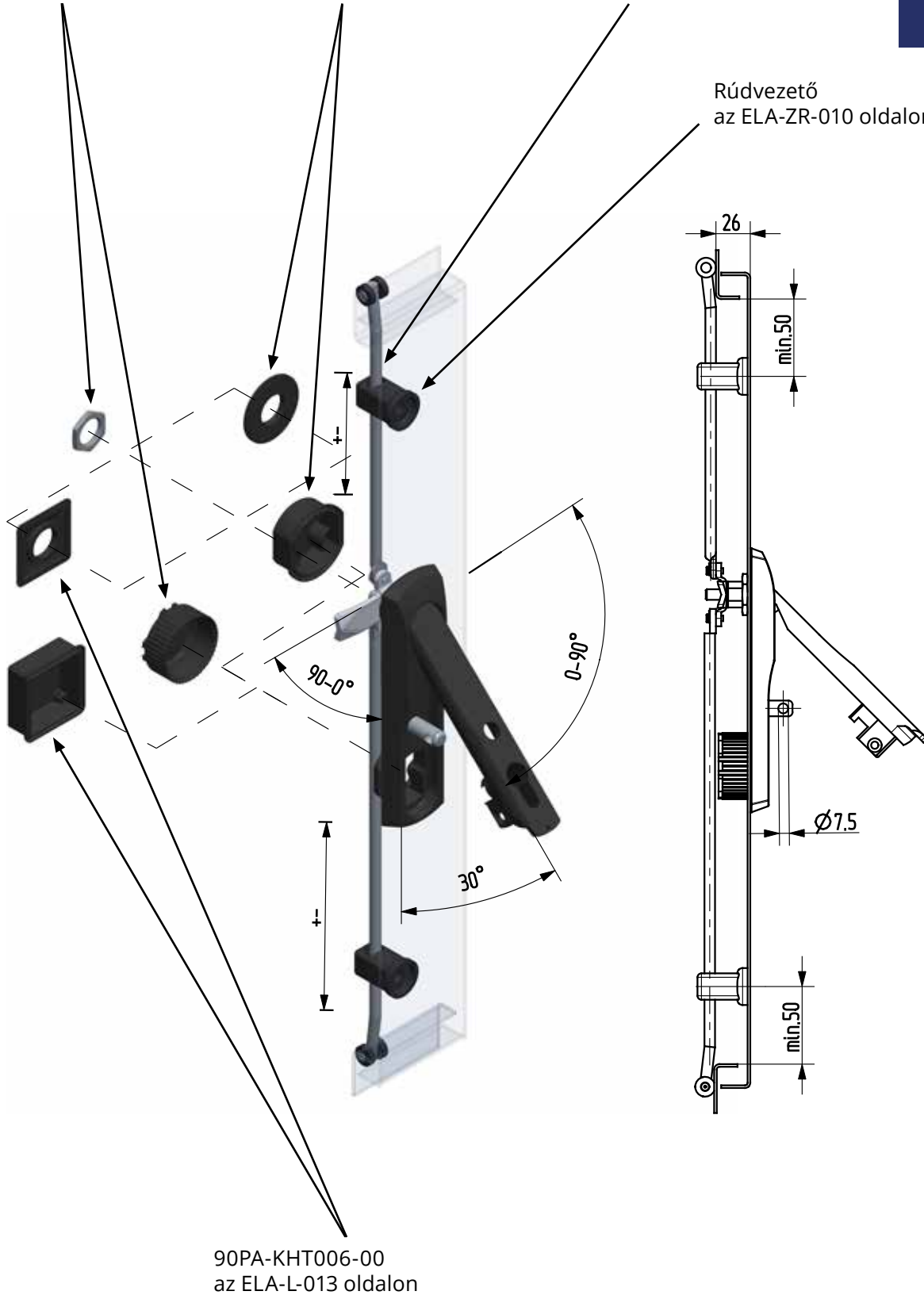

Lengőkarok

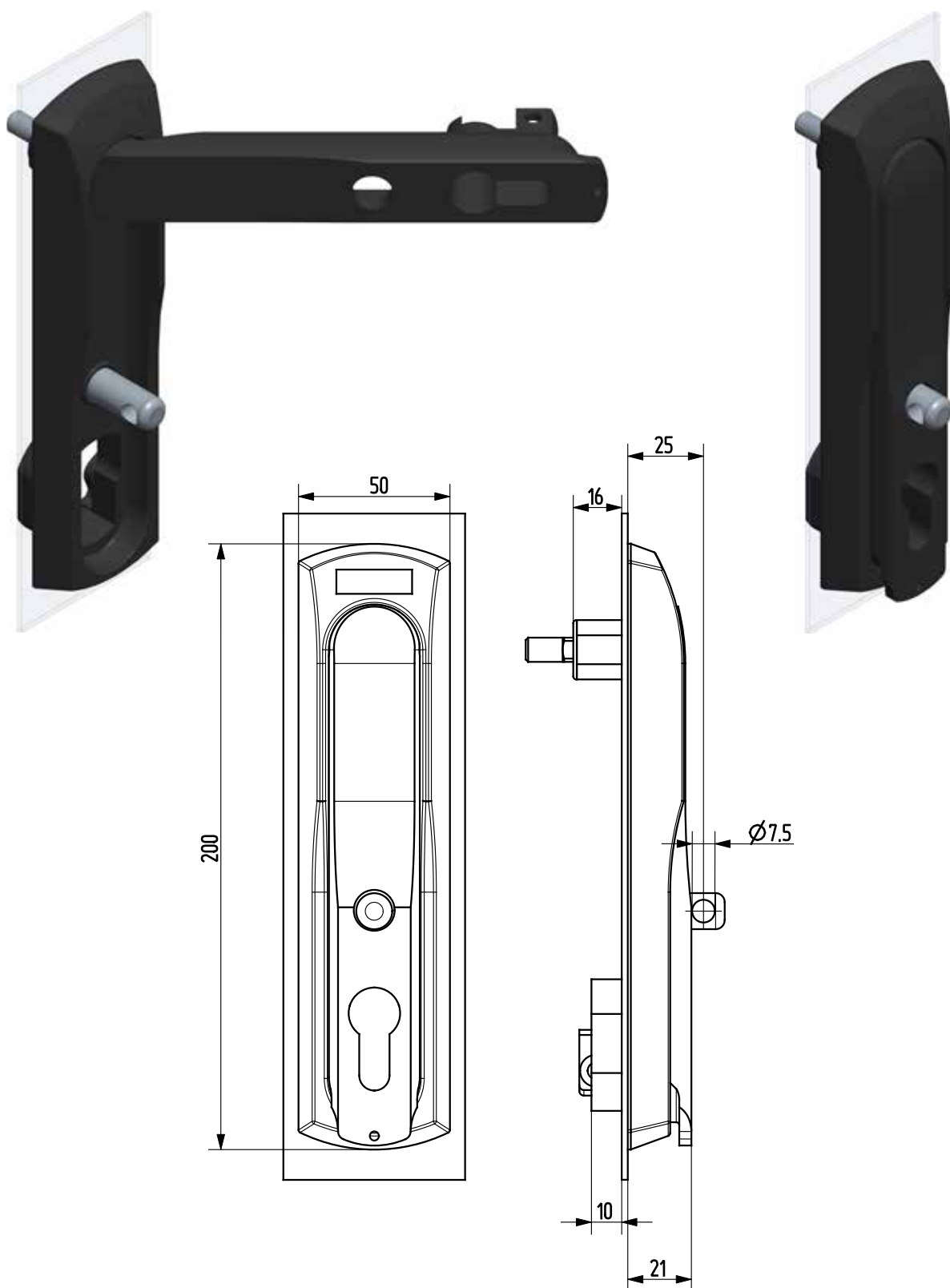

Termékszám
90ZA-KF012-06

Alapanyag
cinköntvény

Felületkezelés
fekete porszórt

Lengőkarok

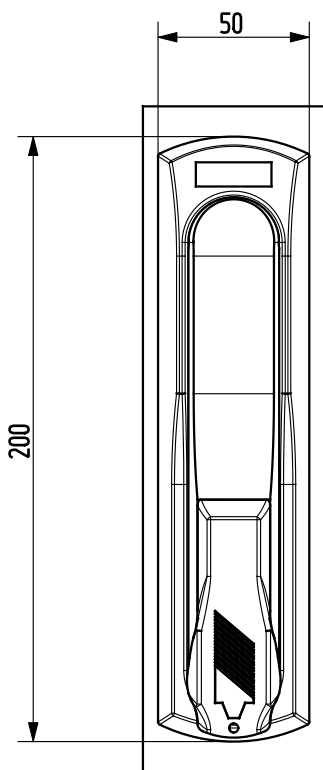

Termékszám

90ZA-KF013-06

Alapanyag

cinköntvény

Felületkezelés

fekete porszórt

Lengőkarok

Tartozékok a 90ZA-KF012-06 és 90ZA-KF012-06 termékekhez



Termékszám	Alapanyag	Felületkezelés
90PA-KHT003-00	PA	-

Termékszám	Alapanyag	Felületkezelés
90PA-KHT001-00	PA	-



Termékszám	Alapanyag	Felületkezelés
90PA-KHT005-00	PA	-

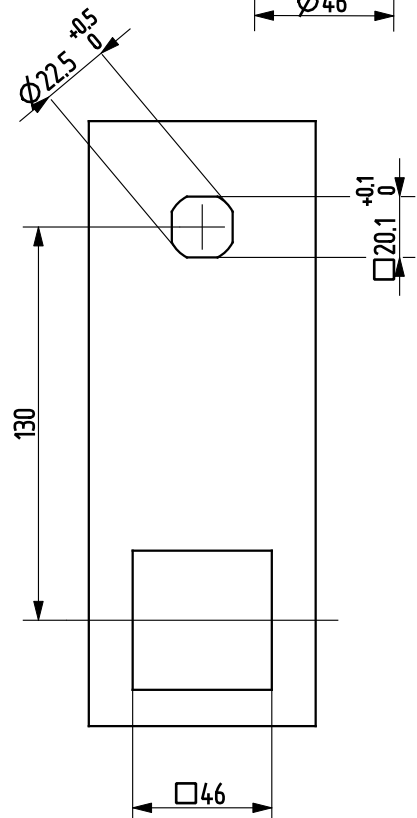
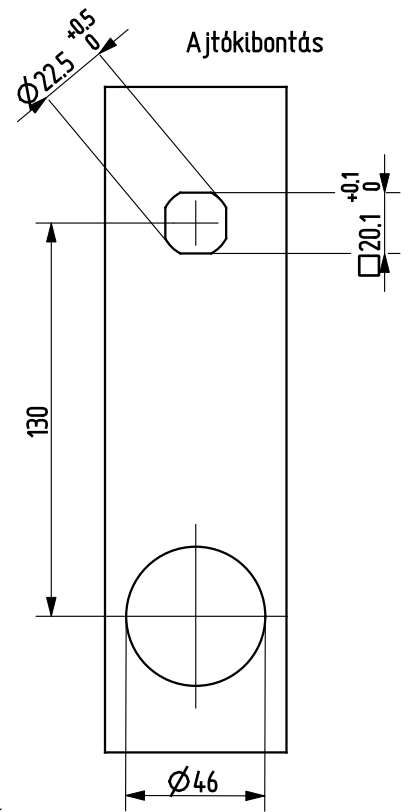

Lengőkarok

Cilinderfedelek

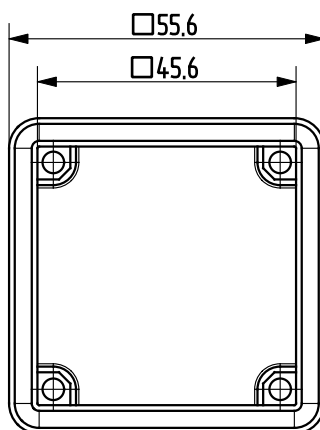
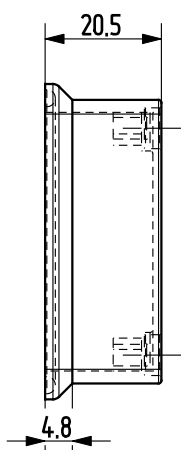
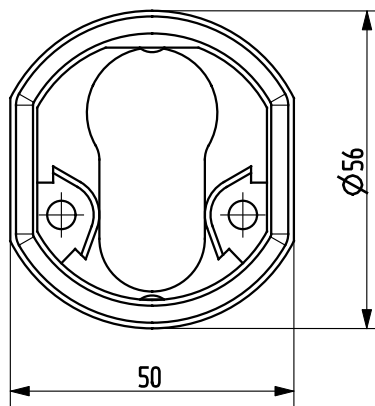
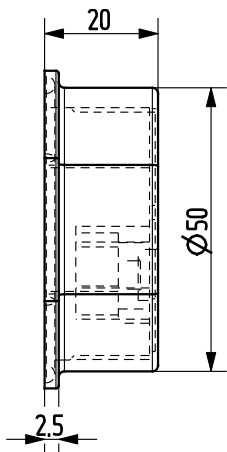
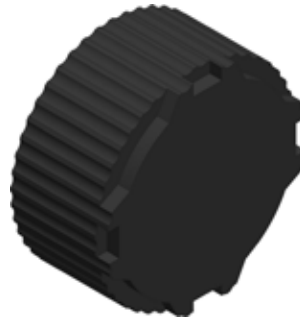
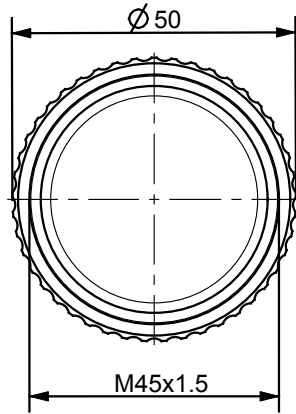
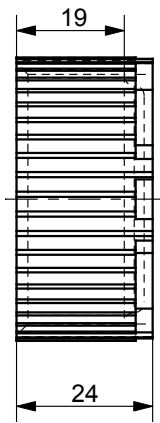

Lengőkarok

Tartozékok a 90ZA-KF012-06 és 90ZA-KF012-06 termékekhez



Termékszám	Alapanyag	Felületkezelés
90PA-KHT004-00	PA	-

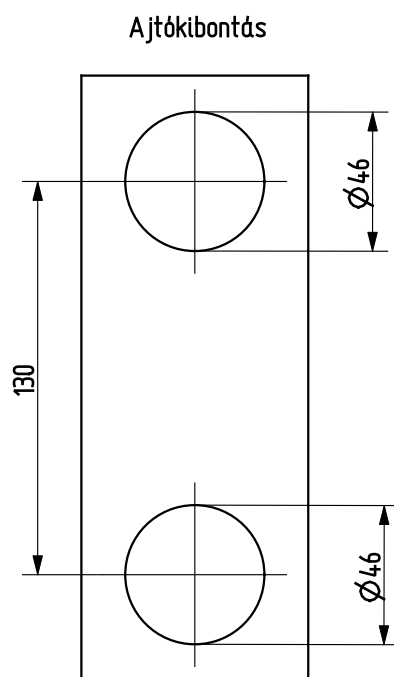

Termékszám	Alapanyag	Felületkezelés
90PA-KHT002-00	PA	-



Termékszám	Alapanyag	Felületkezelés
90PA-KHT006-00	PA	-

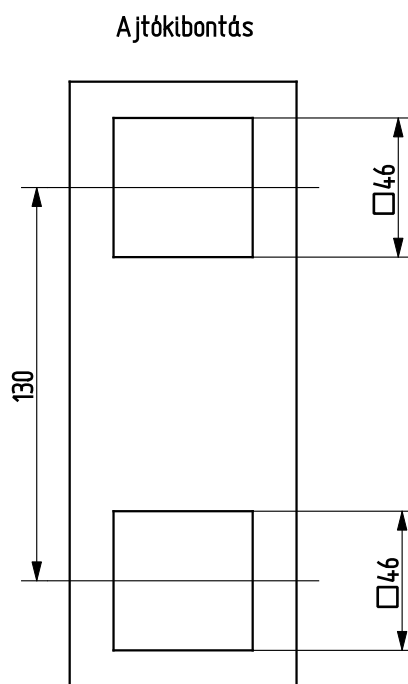

Lengőkarok

Adapterek

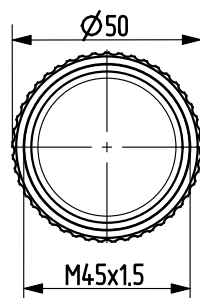
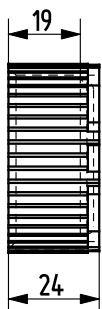
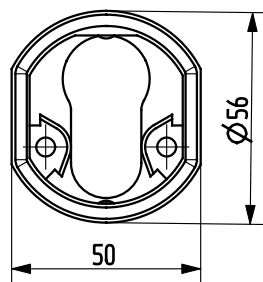
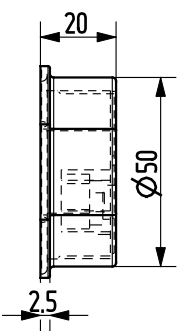
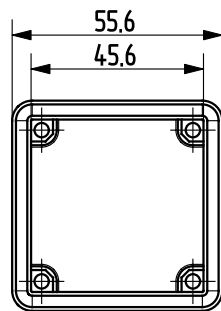
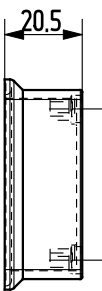
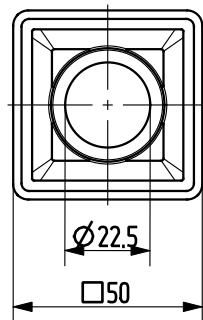
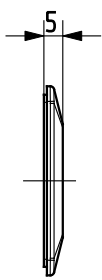
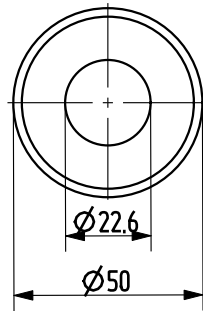
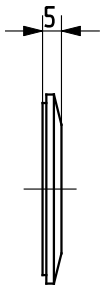

Cilinderfedelek

Lengőkarok

Beltéri lengőkarok



Lengőkarok



A cylinderbetét
nem tartozék!

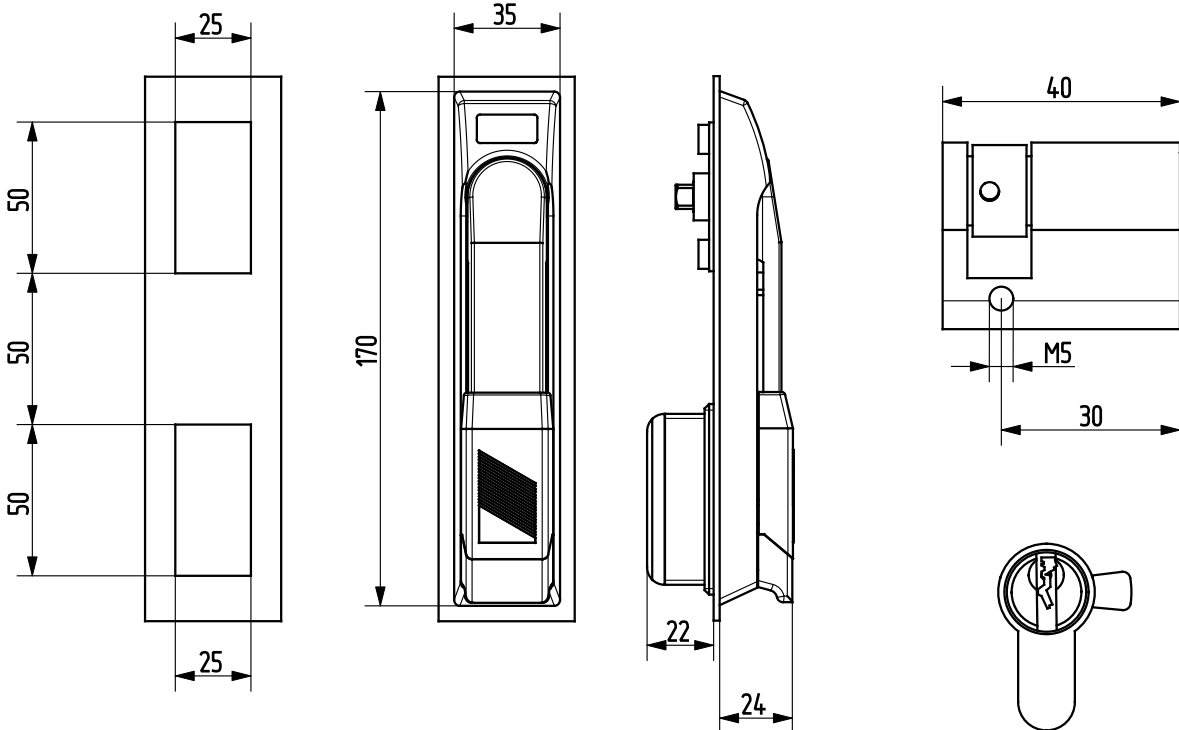

Ajtókibontás

Termékszám	Alapanyag	Felületkezelés
90PA-KF011-00	PA	-

Lengőkarok

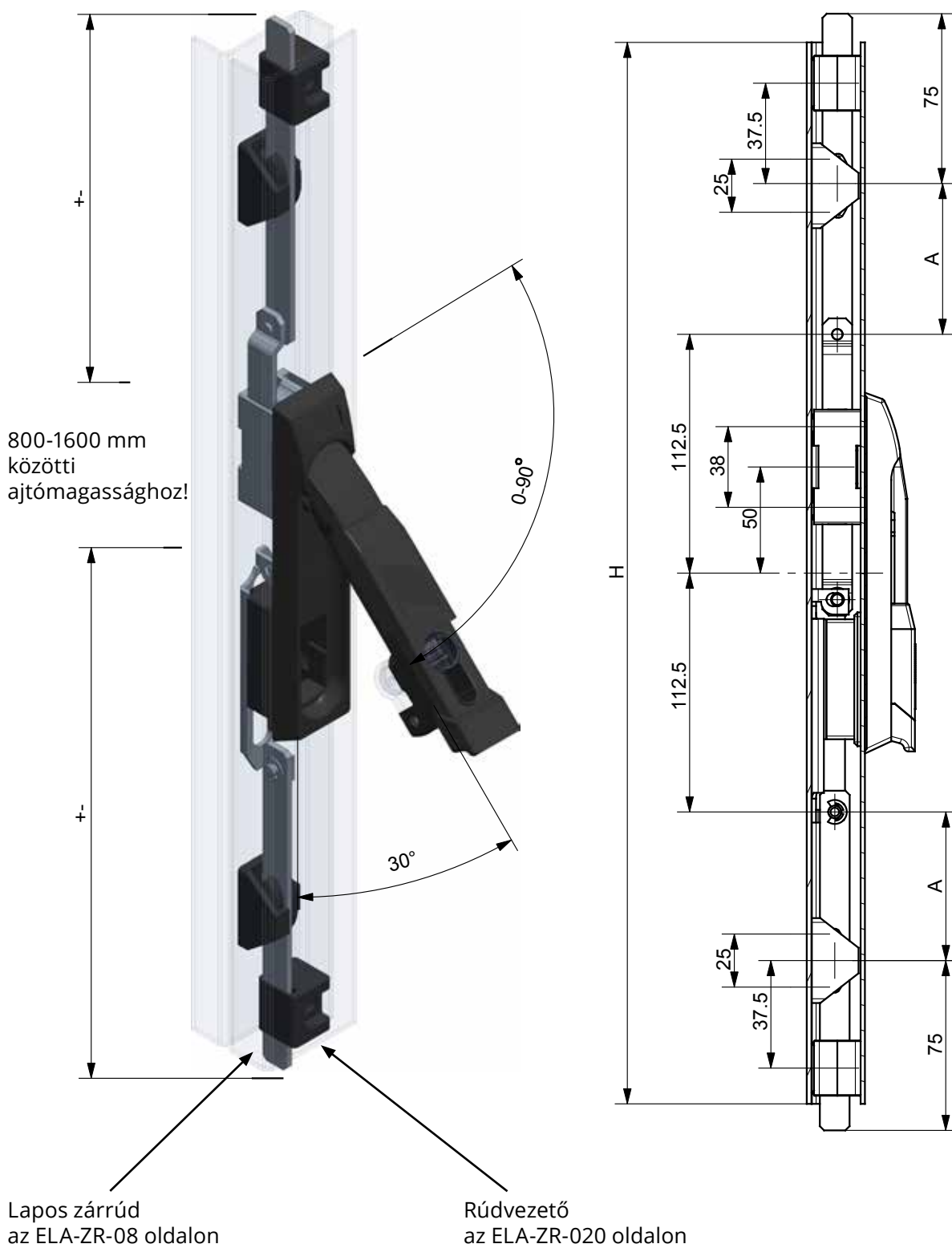

Ajtómagasság H (mm)	A
800-1200	126.5
1200-1600	276.5

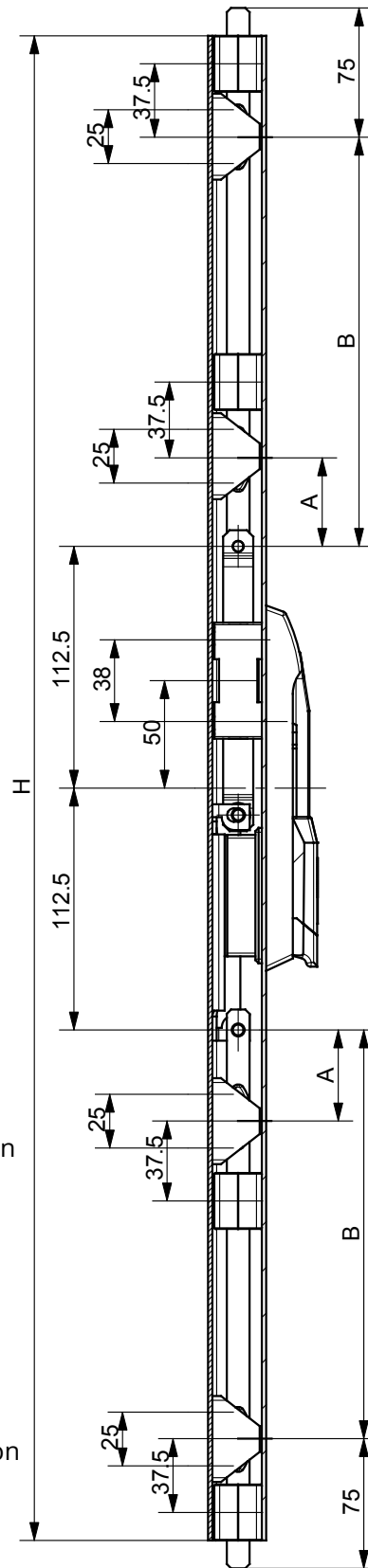
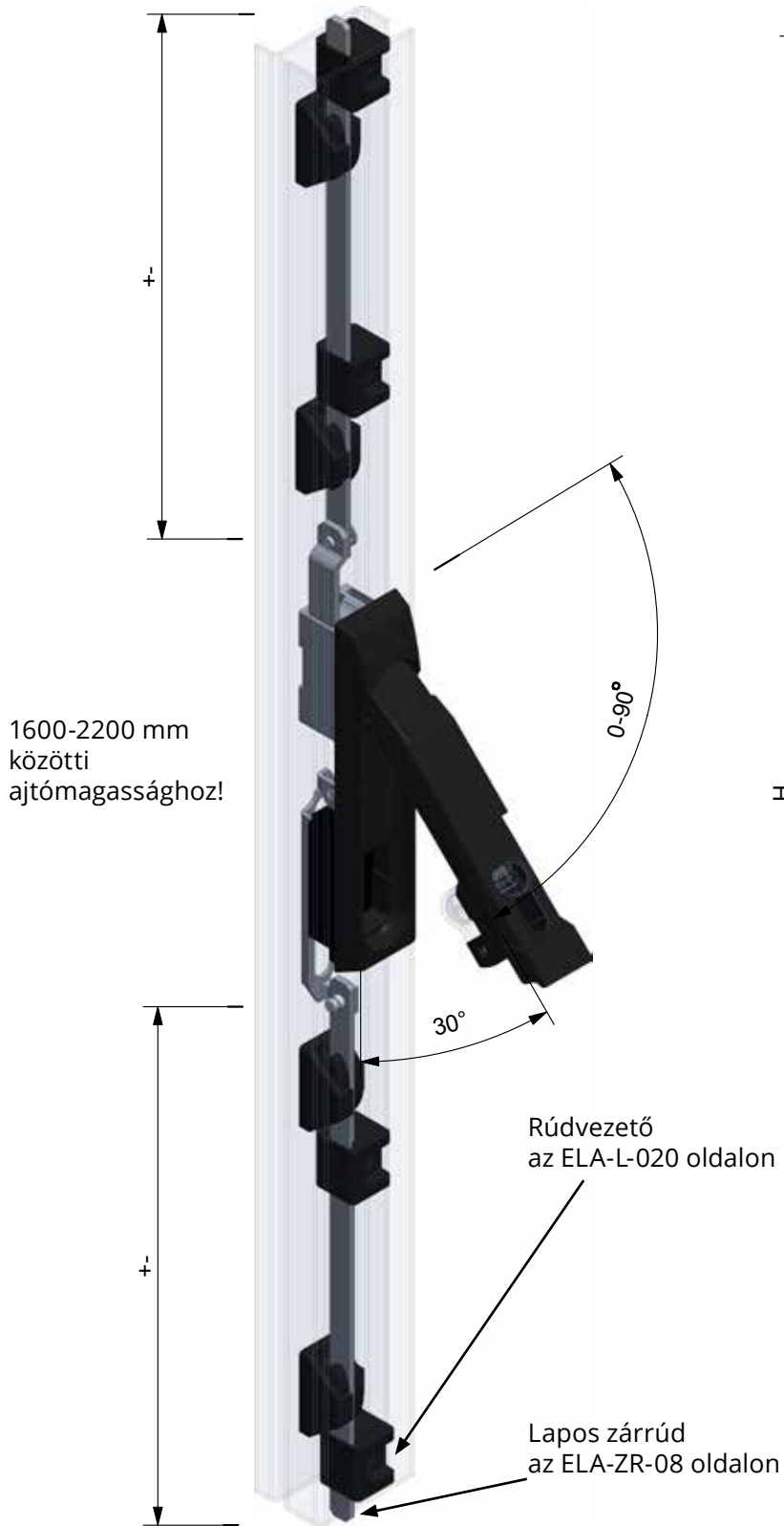

Ajtómagasság H (mm)	A	B
1600-1900	101.5	526.5
1900-2200	101.5	676.5

Lengőkarok

Tolózár

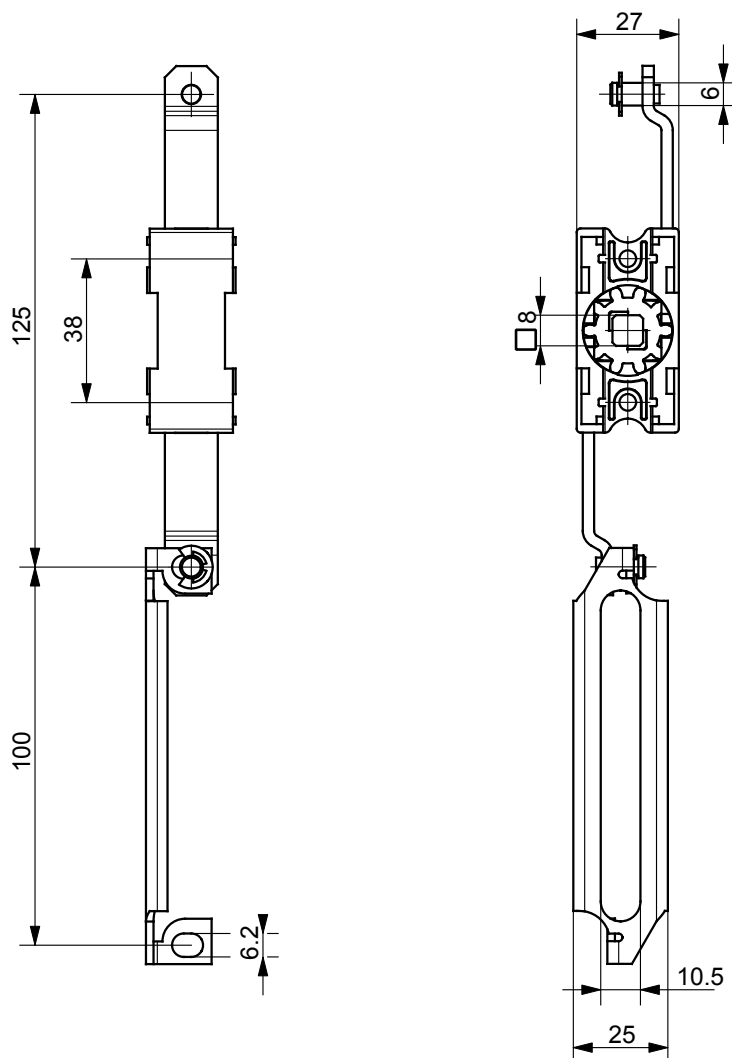
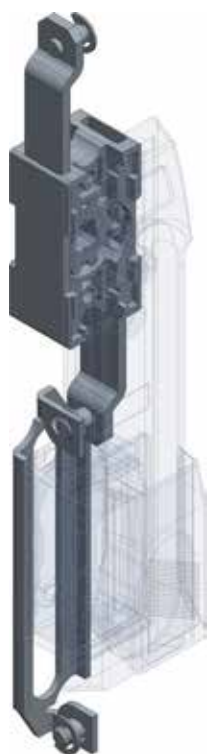

Termékszám	Alapanyag	Felületkezelés
90ZA-KZA001-00	cinköntvény	-

Lengőkarok

Záróelem

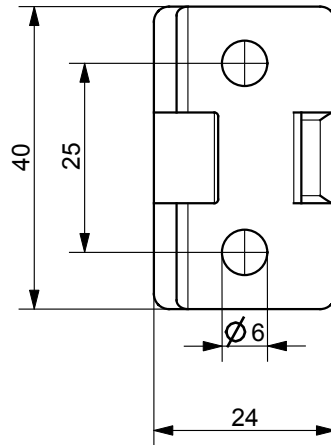
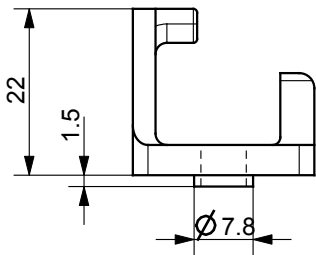

Termékszám	Alapanyag	Felületkezelés
90PA-HT012-00	poliamid	-

Rúdvezető

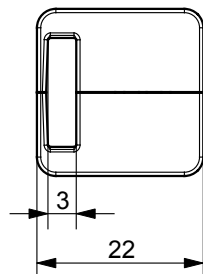
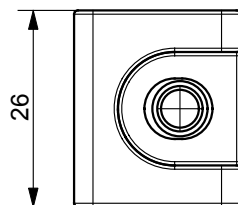
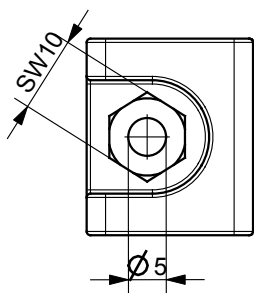

Termékszám	Alapanyag	Felületkezelés
90PA-KHT007-00	poliamid	-

Lengőkarok

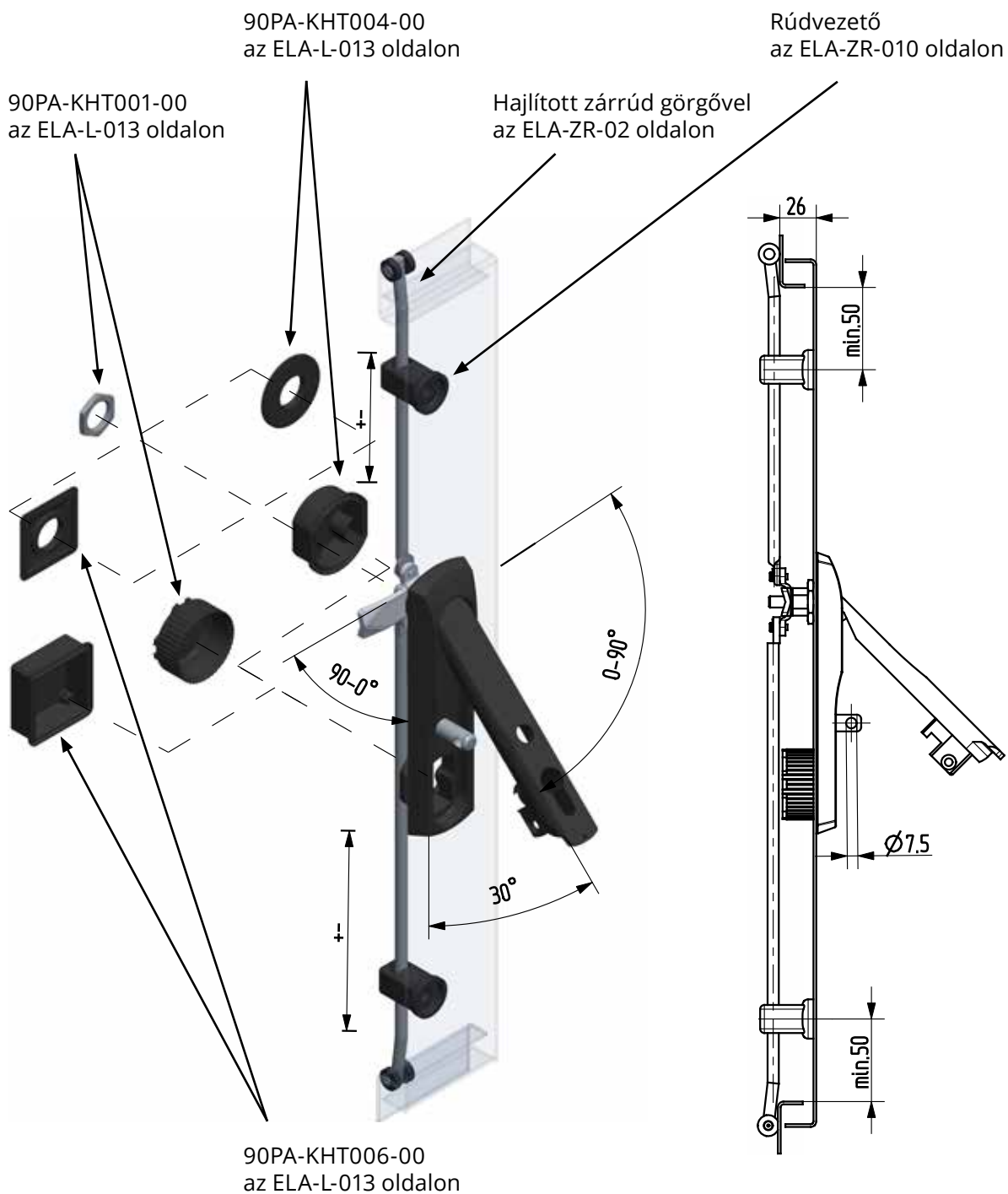

Lengőkarok

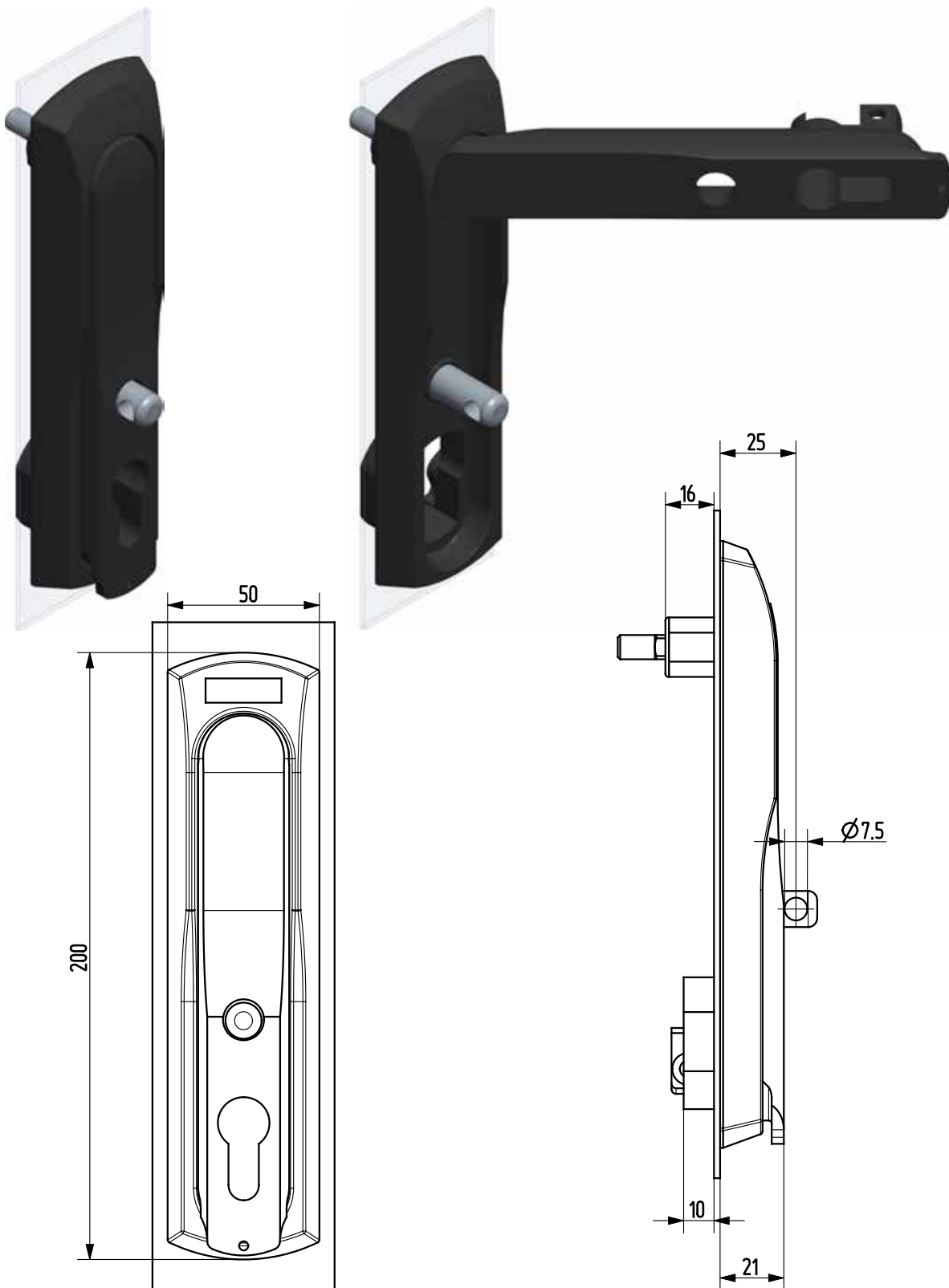

Termékszám

90PA-KF012-00

Alapanyag

PA

Felületkezelés

-

Lengőkarok

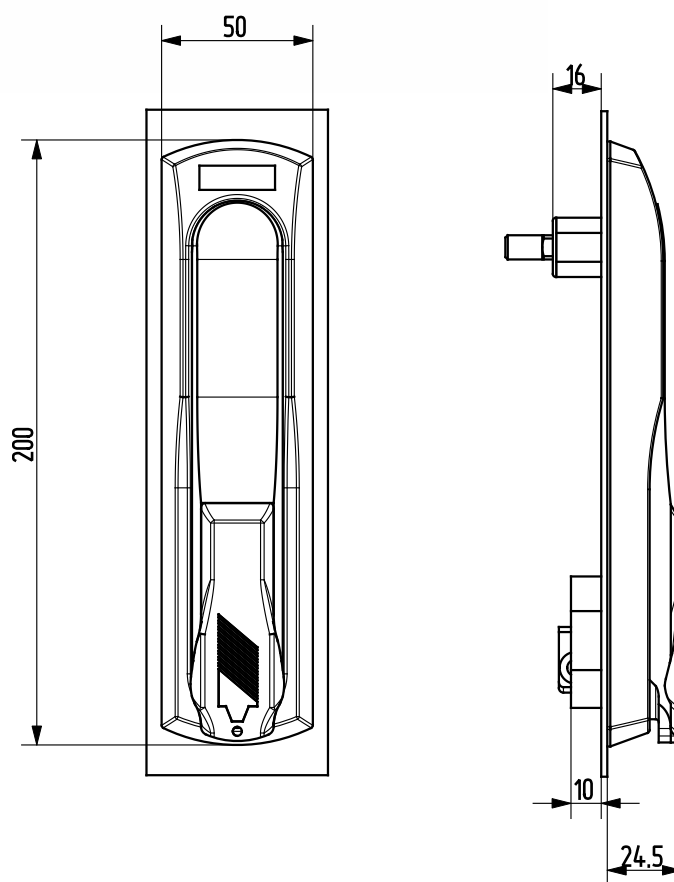
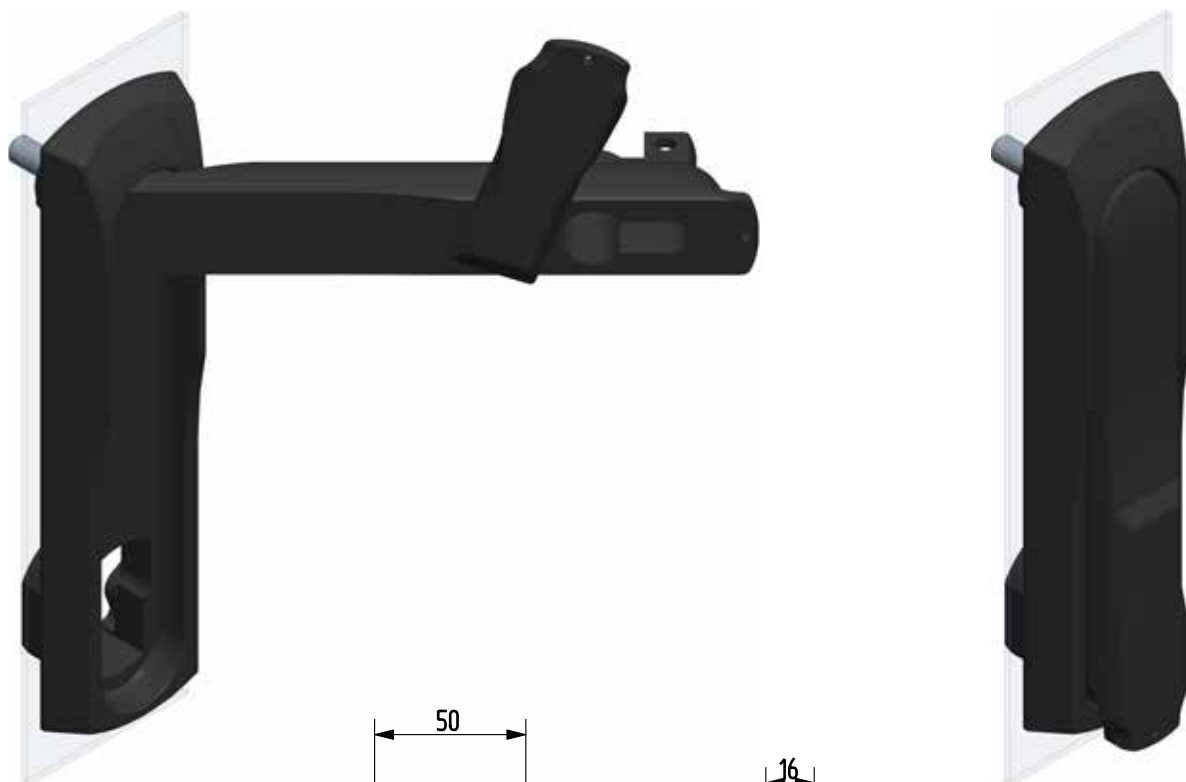

Termékszám	Alapanyag	Felületkezelés
90PA-KF013-00	PA	-

Tartozékok a 90PA-KF012-00 és 90PA-KF013-00 termékekhez



Termékszám	Alapanyag	Felületkezelés
90PA-KHT003-00	PA	-

Termékszám	Alapanyag	Felületkezelés
90PA-KHT001-00	PA	-

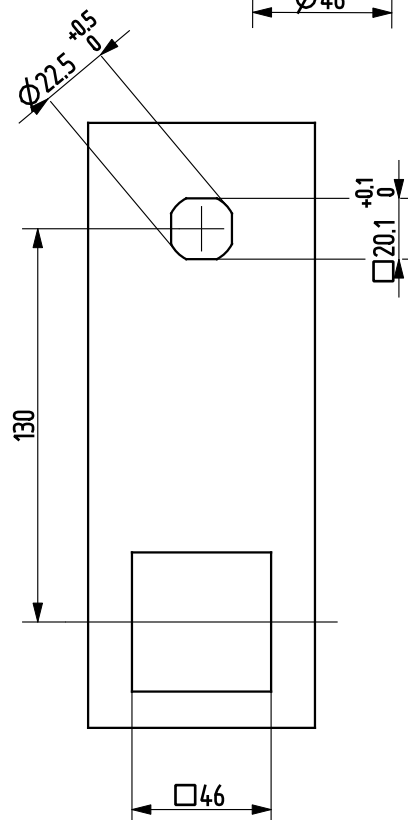
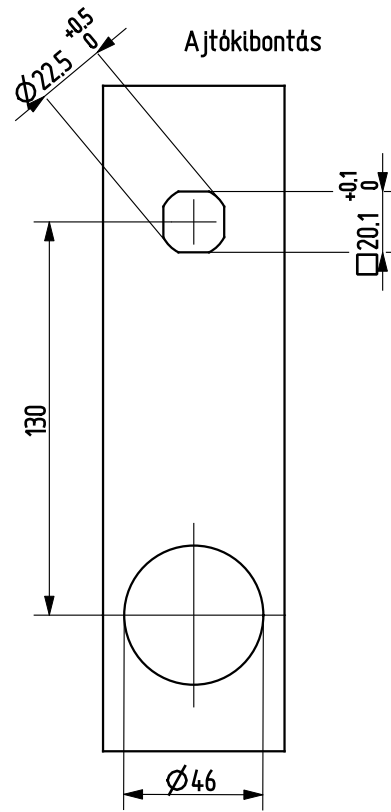

Termékszám	Alapanyag	Felületkezelés
90PA-KHT005-00	PA	-

Lengőkarok

Cilinderfedelek

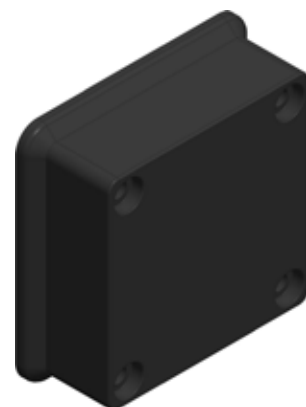
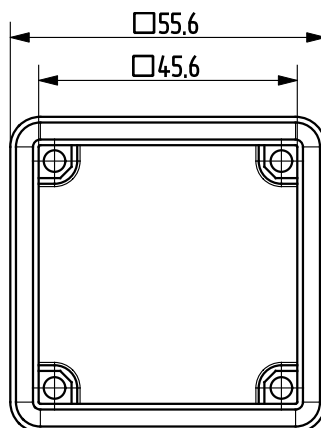
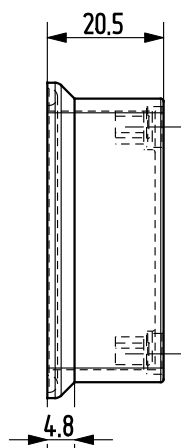
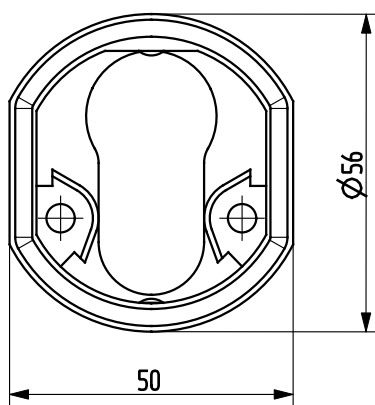
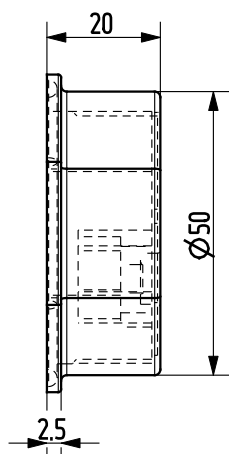
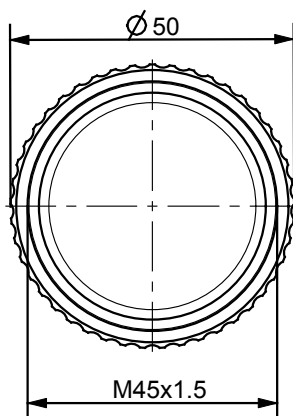
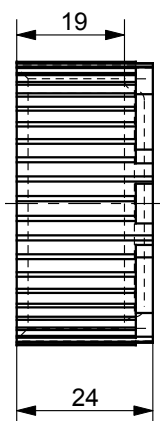

Tartozékok a 90PA-KF012-00 és 90PA-KF013-00 termékekhez



Termékszám	Alapanyag	Felületkezelés
90PA-KHT004-00	PA	-

Termékszám	Alapanyag	Felületkezelés
90PA-KHT002-00	PA	-

Ajtókibontás

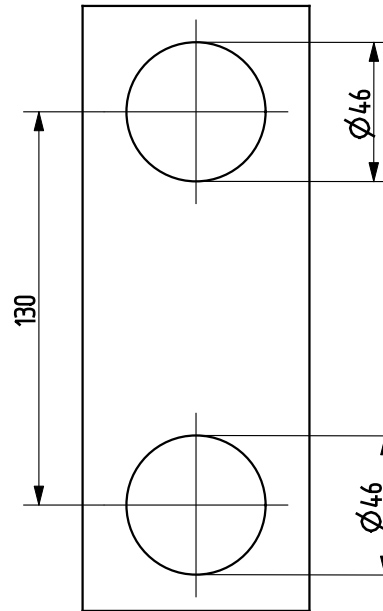

Termékszám	Alapanyag	Felületkezelés
90PA-KHT006-00	PA	-

Ajtókibontás

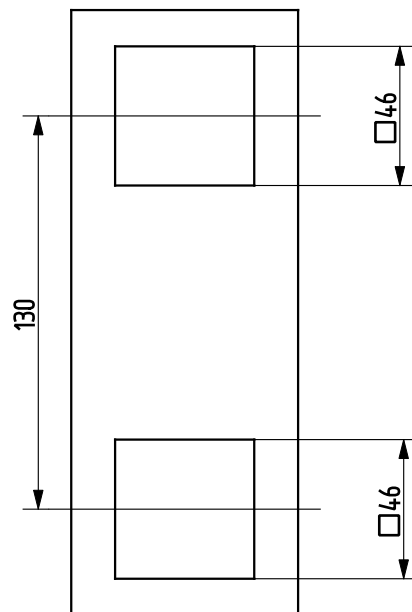

Lengőkarok

Adapterek

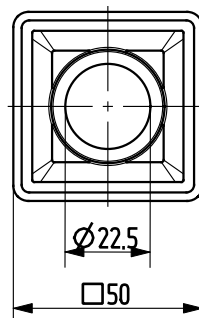
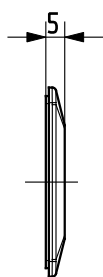
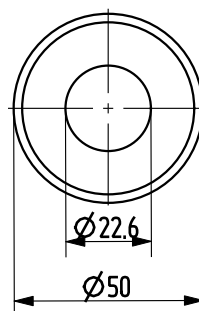
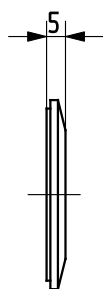

Cilinderfedelek

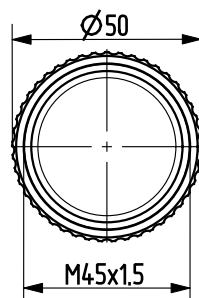
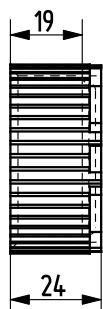
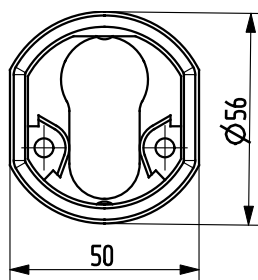
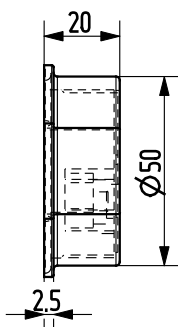
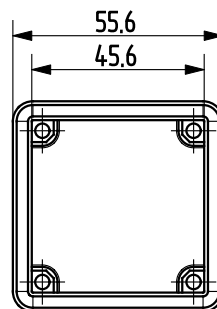
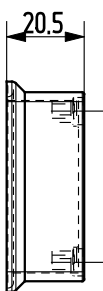



ZÁRRUDAK



Zárrudak

Zárrudak, Adapterek és Rúdvezetők

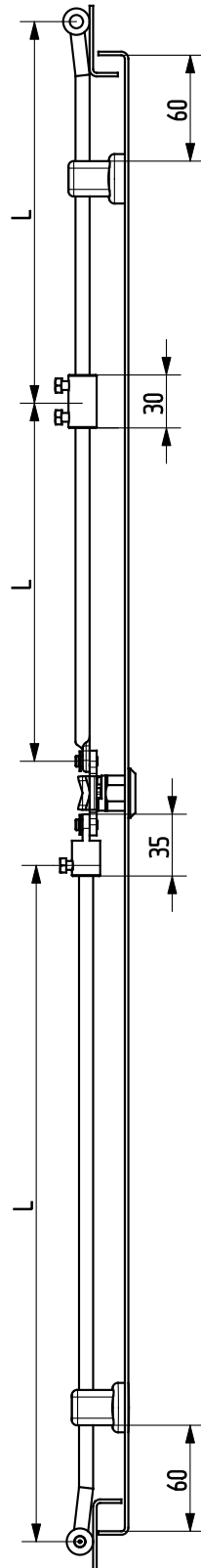

Zárrudak

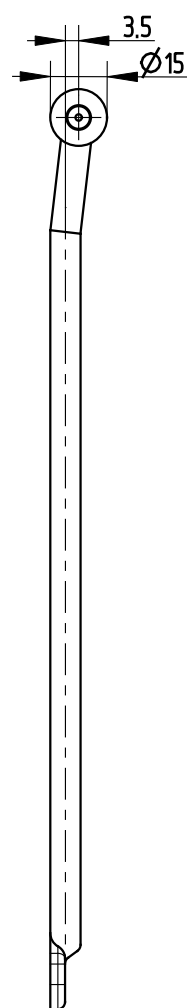
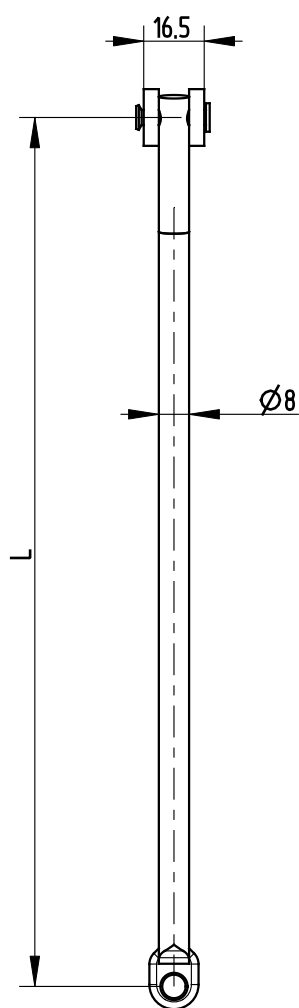

Termékszám	L (mm; tól-ig)	Alap- anyag	Felületkezelés	Termékszám	L (mm; tól-ig)	Alap- anyag	Felületkezelés
90ST-KR041-01	400	ST	horganyozva	90KO-KR041-00	400	1.4301	-
90ST-KR042-01	401 450	ST	horganyozva	90KO-KR042-00	401 450	1.4301	-
90ST-KR043-01	451 500	ST	horganyozva	90KO-KR043-00	451 500	1.4301	-
90ST-KR044-01	501 550	ST	horganyozva	90KO-KR044-00	501 550	1.4301	-
90ST-KR045-01	551 600	ST	horganyozva	90KO-KR045-00	551 600	1.4301	-
90ST-KR046-01	601 650	ST	horganyozva	90KO-KR046-00	601 650	1.4301	-
90ST-KR047-01	651 700	ST	horganyozva	90KO-KR047-00	651 700	1.4301	-
90ST-KR048-01	701 750	ST	horganyozva	90KO-KR048-00	701 750	1.4301	-
90ST-KR049-01	751 800	ST	horganyozva	90KO-KR049-00	751 800	1.4301	-
90ST-KR050-01	801 850	ST	horganyozva	90KO-KR050-00	801 850	1.4301	-
90ST-KR051-01	851 900	ST	horganyozva	90KO-KR051-00	851 900	1.4301	-
90ST-KR052-01	901 950	ST	horganyozva	90KO-KR052-00	901 950	1.4301	-
90ST-KR053-01	951 1000	ST	horganyozva	90KO-KR053-00	951 1000	1.4301	-
90ST-KR054-01	1001 1050	ST	horganyozva	90KO-KR054-00	1001 1050	1.4301	-
90ST-KR055-01	1051 1100	ST	horganyozva	90KO-KR055-00	1051 1100	1.4301	-
90ST-KR056-01	1101 1150	ST	horganyozva	90KO-KR056-00	1101 1150	1.4301	-
90ST-KR057-01	1151 1200	ST	horganyozva	90KO-KR057-00	1151 1200	1.4301	-

Megjegyzés:
minimális rendelési
mennyiség 100 db
(felár felszámolása
mellett kisebb
mennyiség is
rendelhető)

Zárrudak

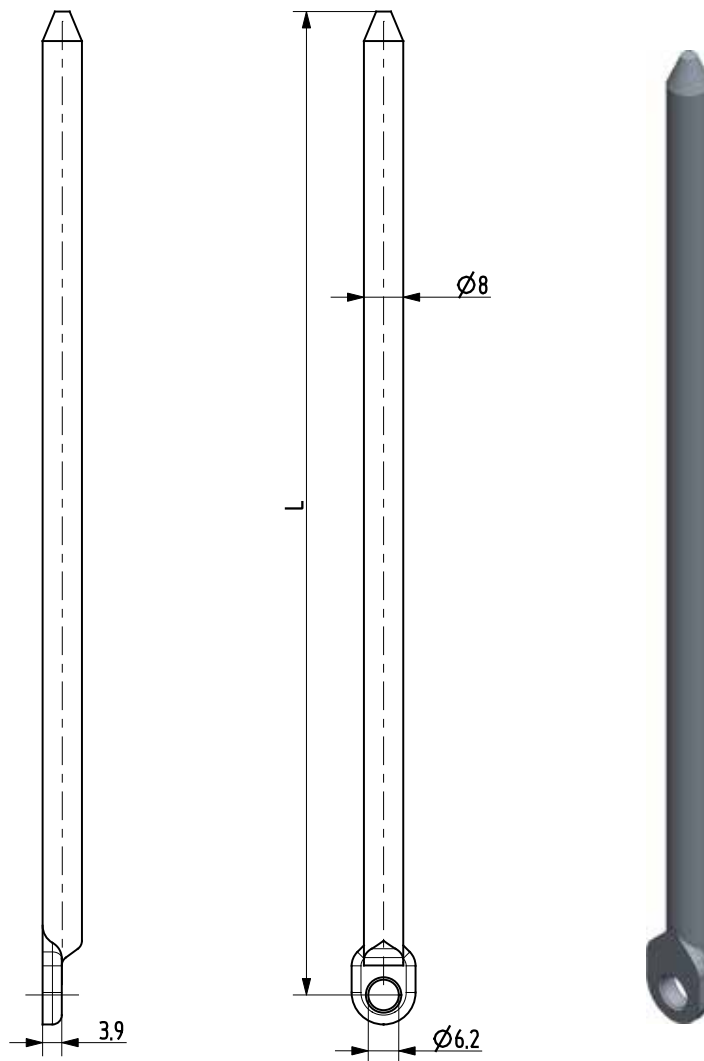

Megjegyzés:
minimális rendelési
mennyiség 100 db
(felár felszámolása
mellett kisebb
mennyiség is
rendelhető)

Termékszám	L (mm; tól-ig)	Alap- anyag	Felületkezelés	Termékszám	L (mm; tól-ig)	Alap- anyag	Felületkezelés
90ST-R001-01	400	ST	horganyozva	90KO-R001-00	400	1.4301	-
90ST-R002-01	401 450	ST	horganyozva	90KO-R002-00	401 450	1.4301	-
90ST-R003-01	451 500	ST	horganyozva	90KO-R003-00	451 500	1.4301	-
90ST-R004-01	501 550	ST	horganyozva	90KO-R004-00	501 550	1.4301	-
90ST-R005-01	551 600	ST	horganyozva	90KO-R005-00	551 600	1.4301	-
90ST-R006-01	601 650	ST	horganyozva	90KO-R006-00	601 650	1.4301	-
90ST-R007-01	651 700	ST	horganyozva	90KO-R007-00	651 700	1.4301	-
90ST-R008-01	701 750	ST	horganyozva	90KO-R008-00	701 750	1.4301	-
90ST-R009-01	751 800	ST	horganyozva	90KO-R009-00	751 800	1.4301	-
90ST-R010-01	801 850	ST	horganyozva	90KO-R010-00	801 850	1.4301	-
90ST-R011-01	851 900	ST	horganyozva	90KO-R011-00	851 900	1.4301	-
90ST-R012-01	901 950	ST	horganyozva	90KO-R012-00	951 1000	1.4301	-
90ST-R013-01	951 1000	ST	horganyozva	90KO-R013-00	1001 1050	1.4301	-
90ST-R014-01	1001 1050	ST	horganyozva	90KO-R014-00	1051 1100	1.4301	-
90ST-R015-01	1051 1100	ST	horganyozva	90KO-R015-00	1101 1150	1.4301	-
90ST-R016-01	1101 1150	ST	horganyozva	90KO-R016-00	1151 1200	1.4301	-
90ST-R017-01	1151 1200	ST	horganyozva				

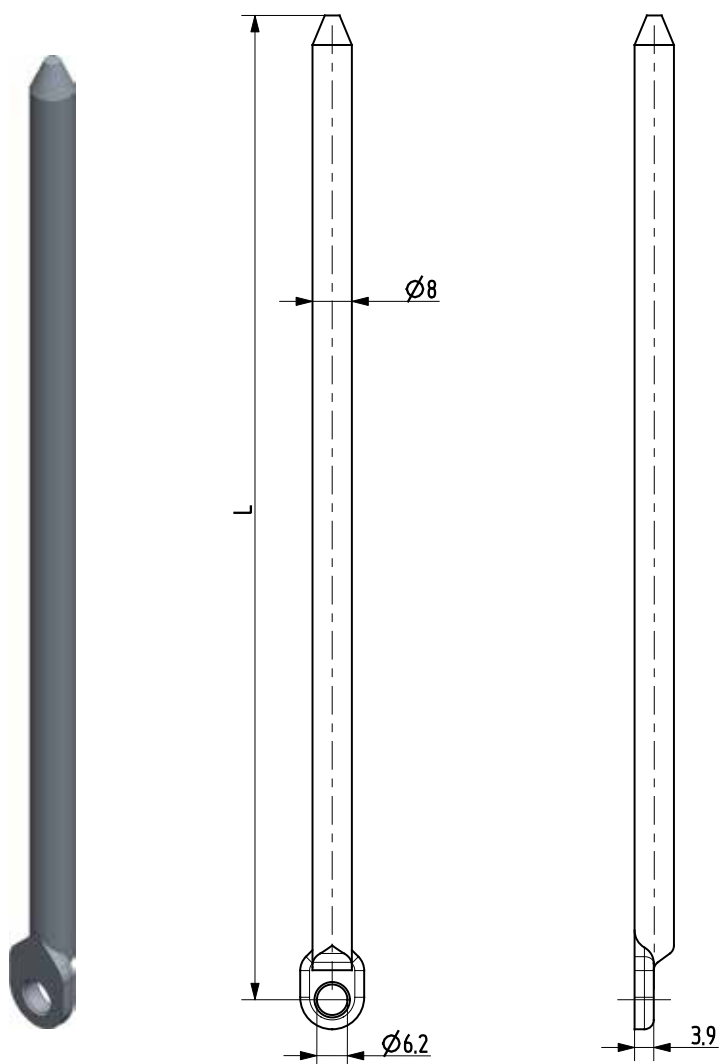

Termékszám	L (mm; tól-ig)	Alap- anyag	Felületkezelés	Termékszám	L (mm; tól-ig)	Alap- anyag	Felületkezelés		
90ST-R021-01	400	ST	horganyozva	90KO-R021-00	400	1.4301	-		
90ST-R022-01	401	450	ST	horganyozva	90KO-R022-00	401	450	1.4301	-
90ST-R023-01	451	500	ST	horganyozva	90KO-R023-00	451	500	1.4301	-
90ST-R024-01	501	550	ST	horganyozva	90KO-R024-00	501	550	1.4301	-
90ST-R025-01	551	600	ST	horganyozva	90KO-R025-00	551	600	1.4301	-
90ST-R026-01	601	650	ST	horganyozva	90KO-R026-00	601	650	1.4301	-
90ST-R027-01	651	700	ST	horganyozva	90KO-R027-00	651	700	1.4301	-
90ST-R028-01	701	750	ST	horganyozva	90KO-R028-00	701	750	1.4301	-
90ST-R029-01	751	800	ST	horganyozva	90KO-R029-00	751	800	1.4301	-
90ST-R030-01	801	850	ST	horganyozva	90KO-R030-00	801	850	1.4301	-
90ST-R031-01	851	900	ST	horganyozva	90KO-R031-00	851	900	1.4301	-
90ST-R032-01	901	950	ST	horganyozva	90KO-R032-00	901	950	1.4301	-
90ST-R033-01	951	1000	ST	horganyozva	90KO-R033-00	951	1000	1.4301	-
90ST-R034-01	1001	1050	ST	horganyozva	90KO-R034-00	1001	1050	1.4301	-
90ST-R035-01	1051	1100	ST	horganyozva	90KO-R035-00	1051	1100	1.4301	-
90ST-R036-01	1101	1150	ST	horganyozva	90KO-R036-00	1101	1150	1.4301	-
90ST-R037-01	1151	1200	ST	horganyozva	90KO-R037-00	1151	1200	1.4301	-

Megjegyzés:
 minimális rendelési
 mennyiség 100 db
 (felár felszámolása
 mellett kisebb
 mennyiség is
 rendelhető)

Zárrudak

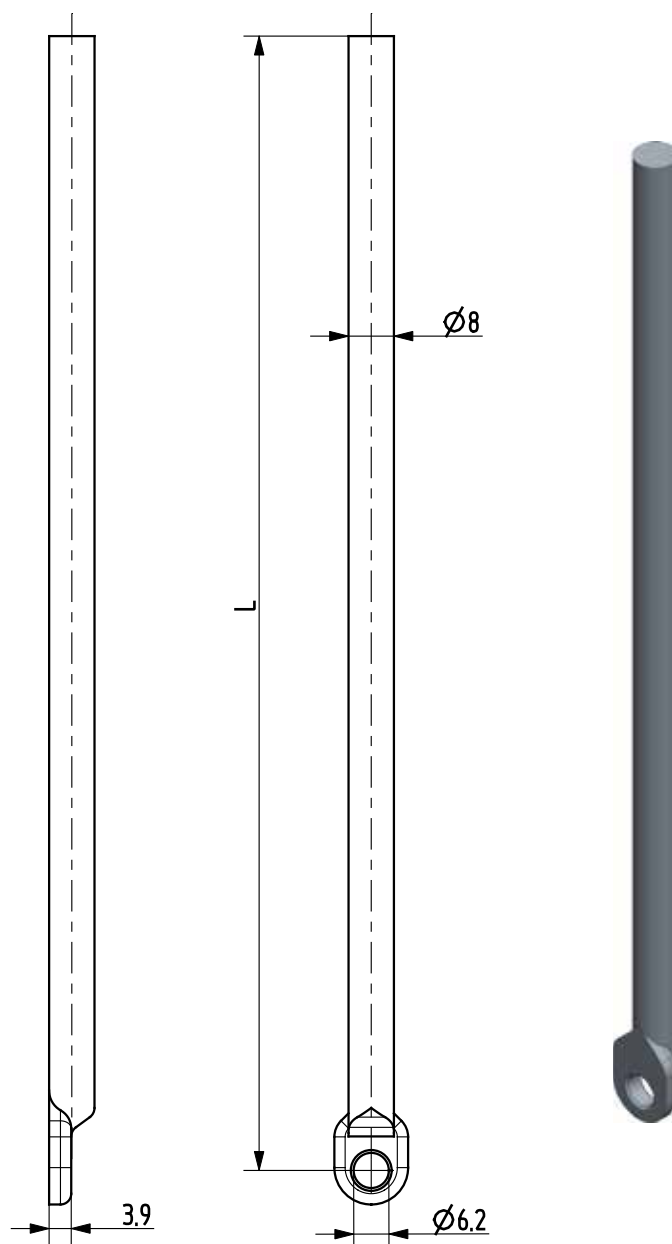

Termékszám	L (mm)	Alapanyag	Felületkezelés	Termékszám	L (mm)	Alapanyag	Felületkezelés
90ST-R076-01	400	ST	horganyozva	90KO-R076-00	400	1.4301	-
90ST-R077-01	500	ST	horganyozva	90KO-R077-00	500	1.4301	-
90ST-R078-01	600	ST	horganyozva	90KO-R078-00	600	1.4301	-
90ST-R079-01	700	ST	horganyozva	90KO-R079-00	700	1.4301	-
90ST-R080-01	800	ST	horganyozva	90KO-R080-00	800	1.4301	-
90ST-R081-01	900	ST	horganyozva	90KO-R081-00	900	1.4301	-
90ST-R082-01	1000	ST	horganyozva	90KO-R082-00	1000	1.4301	-
90ST-R083-01	1100	ST	horganyozva	90KO-R083-00	1100	1.4301	-
90ST-R084-01	1200	ST	horganyozva	90KO-R084-00	1200	1.4301	-

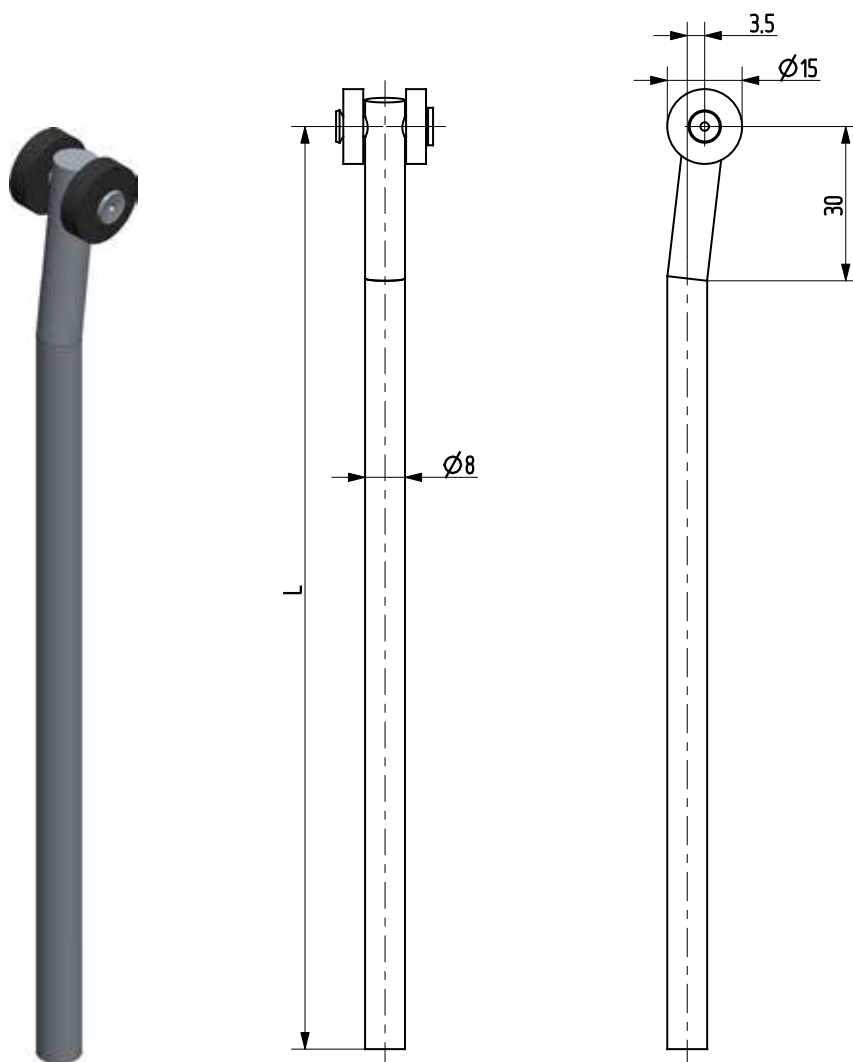

Termékszám	L (mm; tól-ig)	Alap- anyag	Felületkezelés	Termékszám	L (mm; tól-ig)	Alap- anyag	Felületkezelés
90ST-KR061-01	400	ST	horganyozva	90KO-KR061-00	400	1.4301	-
90ST-KR062-01	401 450	ST	horganyozva	90KO-KR062-00	401 450	1.4301	-
90ST-KR063-01	451 500	ST	horganyozva	90KO-KR063-00	451 500	1.4301	-
90ST-KR064-01	501 550	ST	horganyozva	90KO-KR064-00	501 550	1.4301	-
90ST-KR066-01	551 600	ST	horganyozva	90KO-KR065-00	551 600	1.4301	-
90ST-KR067-01	601 650	ST	horganyozva	90KO-KR066-00	601 650	1.4301	-
90ST-KR068-01	651 700	ST	horganyozva	90KO-KR067-00	651 700	1.4301	-
90ST-KR069-01	701 750	ST	horganyozva	90KO-KR068-00	701 750	1.4301	-
90ST-KR070-01	751 800	ST	horganyozva	90KO-KR069-00	751 800	1.4301	-
90ST-KR071-01	801 850	ST	horganyozva	90KO-KR070-00	801 850	1.4301	-
90ST-KR072-01	851 900	ST	horganyozva	90KO-KR071-00	851 900	1.4301	-
90ST-KR073-01	901 950	ST	horganyozva	90KO-KR072-00	901 950	1.4301	-
90ST-KR074-01	951 1000	ST	horganyozva	90KO-KR073-00	951 1000	1.4301	-
90ST-KR075-01	1001 1050	ST	horganyozva	90KO-KR074-00	1001 1050	1.4301	-
90ST-KR076-01	1051 1100	ST	horganyozva	90KO-KR075-00	1051 1100	1.4301	-
90ST-KR077-01	1101 1150	ST	horganyozva	90KO-KR076-00	1101 1150	1.4301	-
90ST-KR078-01	1151 1200	ST	horganyozva	90KO-KR077-00	1151 1200	1.4301	-

Megjegyzés:
 minimális rendelési
 mennyiség 100 db
 (felár felszámolása
 mellett kisebb
 mennyiség is
 rendelhető)

Zárrudak

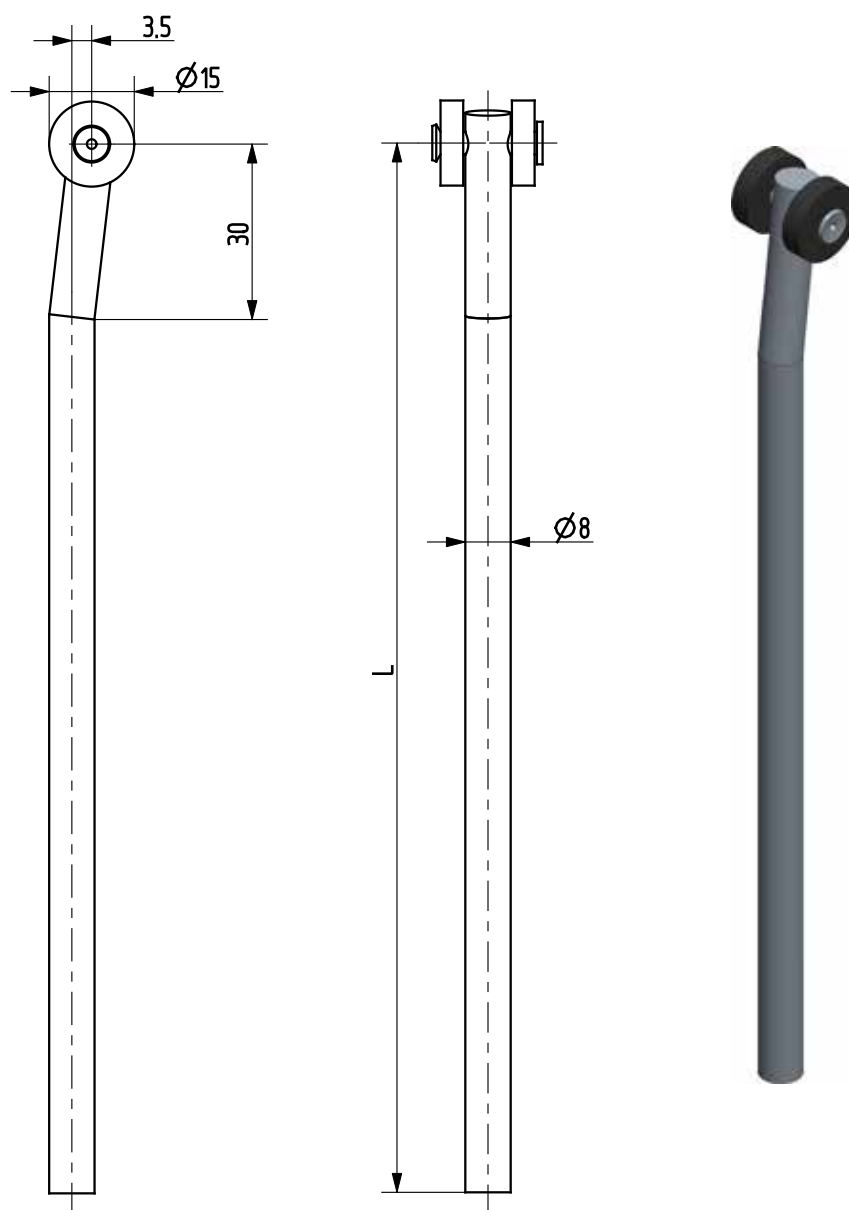

Termékszám	L (mm)	Alapanyag	Felületkezelés	Termékszám	L (mm)	Alapanyag	Felületkezelés
90ST-KR085-01	400	ST	horganyozva	90KO-KR085-00	400	1.4301	-
90ST-KR086-01	500	ST	horganyozva	90KO-KR086-00	500	1.4301	-
90ST-KR087-01	600	ST	horganyozva	90KO-KR087-00	600	1.4301	-
90ST-KR088-01	700	ST	horganyozva	90KO-KR088-00	700	1.4301	-
90ST-KR089-01	800	ST	horganyozva	90KO-KR089-00	800	1.4301	-
90ST-KR090-01	900	ST	horganyozva	90KO-KR090-00	900	1.4301	-
90ST-KR091-01	1000	ST	horganyozva	90KO-KR091-00	1000	1.4301	-
90ST-KR092-01	1100	ST	horganyozva	90KO-KR092-00	1100	1.4301	-
90ST-KR093-01	1200	ST	horganyozva	90KO-KR093-00	1200	1.4301	-

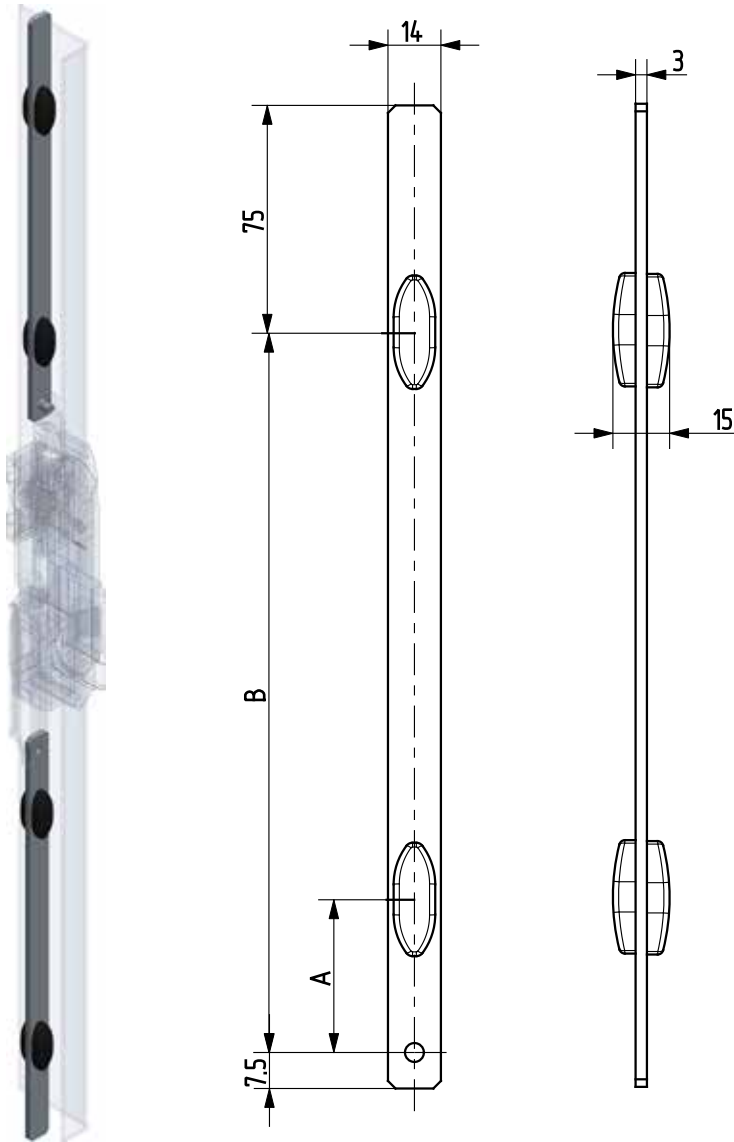

Termékszám	A (mm)	B (mm)	Alapanyag	Felületkezelés
90ST-KR094-01	-	126.5	ST	horganyozva
90ST-KR095-01	-	276.5	ST	horganyozva
90ST-KR096-01	101.5	526.5	ST	horganyozva
90ST-KR097-01	101.5	676.5	ST	horganyozva

Zárrudak

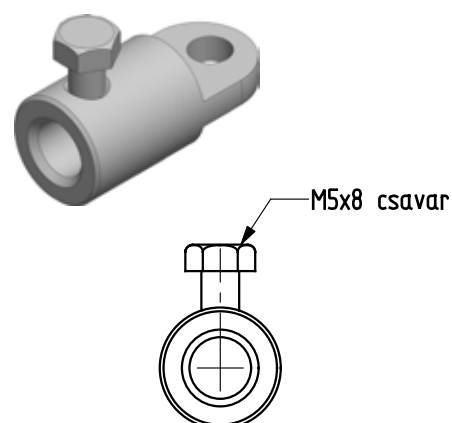
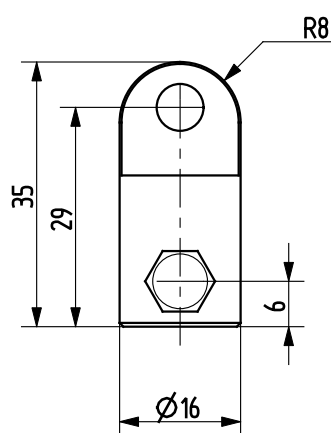
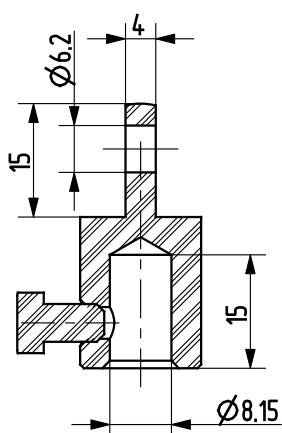

Termékszám	Alapanyag	Felületkezelés
90KO-KAD006-00	1.4305	-

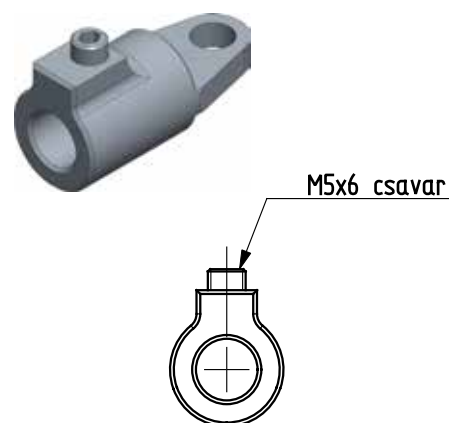
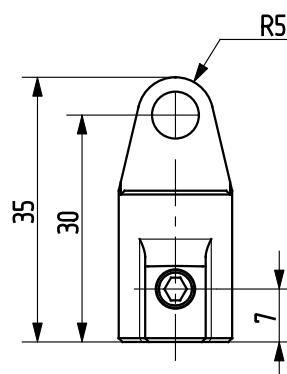
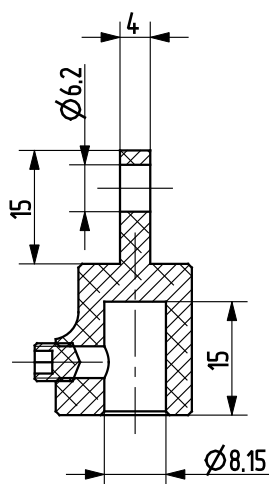

Termékszám	Alapanyag	Felületkezelés
90ZA-KAD001-00	cinköntvény	-

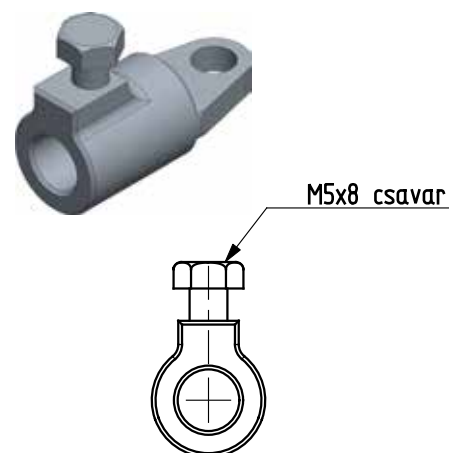
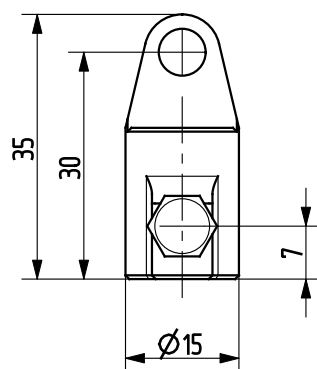
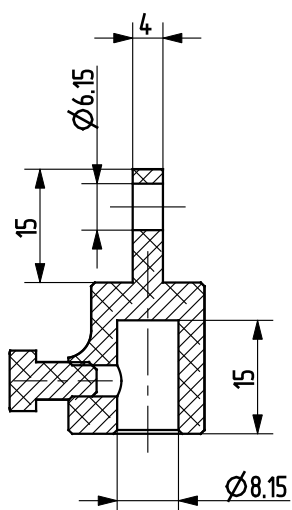

Termékszám	Alapanyag	Felületkezelés
90ZA-KAD002-00	cinköntvény	-

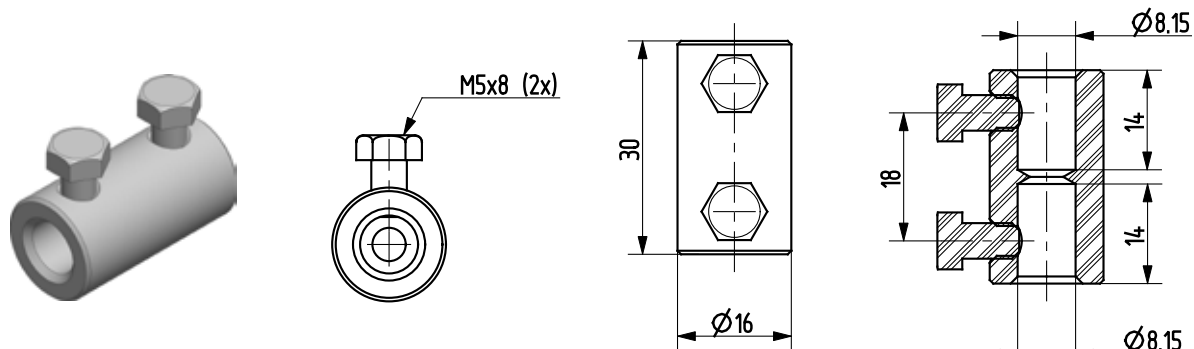

Termékszám	Alapanyag	Felületkezelés
90KO-KAD010-00	1.4305	-

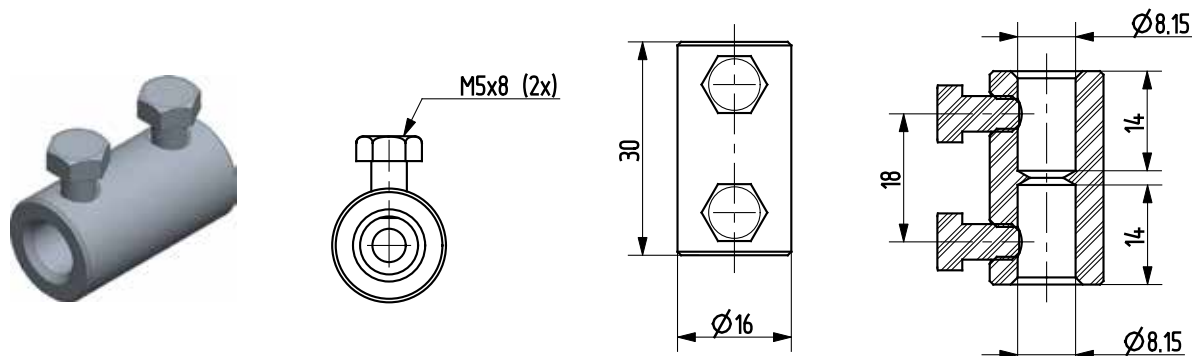

Termékszám	Alapanyag	Felületkezelés
90ST-KAD006-01	ST	horganyozva

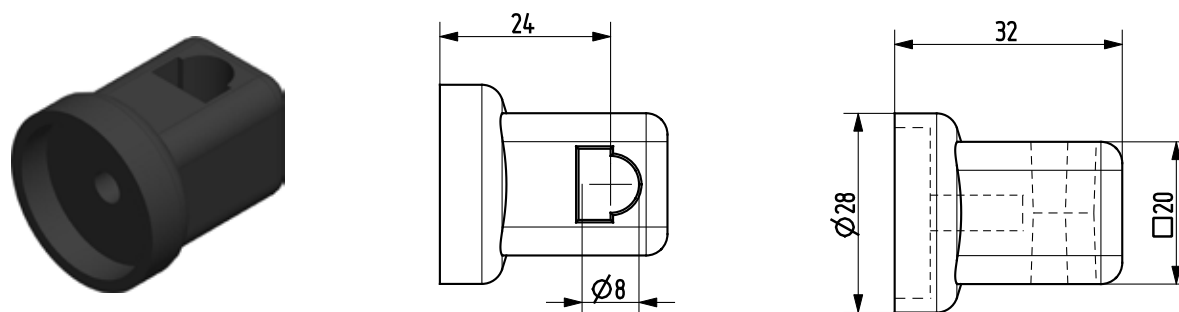

Termékszám	Alapanyag	Felületkezelés
90PA-RV004-00	PA	-

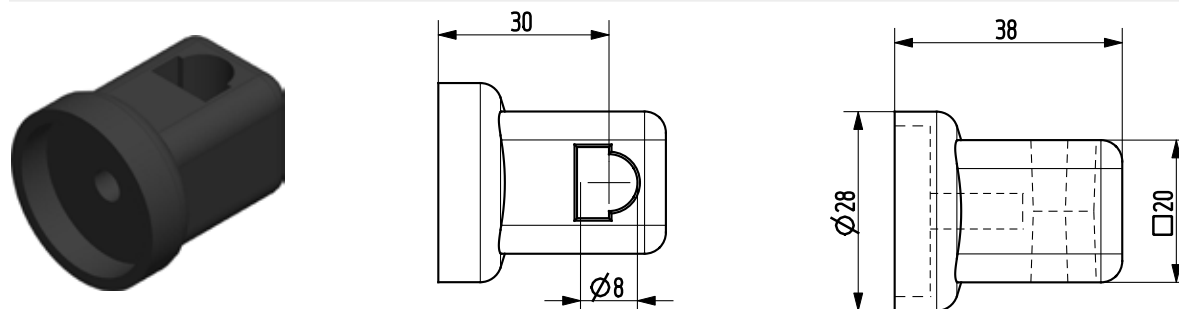

Termékszám	Alapanyag	Felületkezelés
90PA-RV003-00	PA	-



TARTOZÉKOK

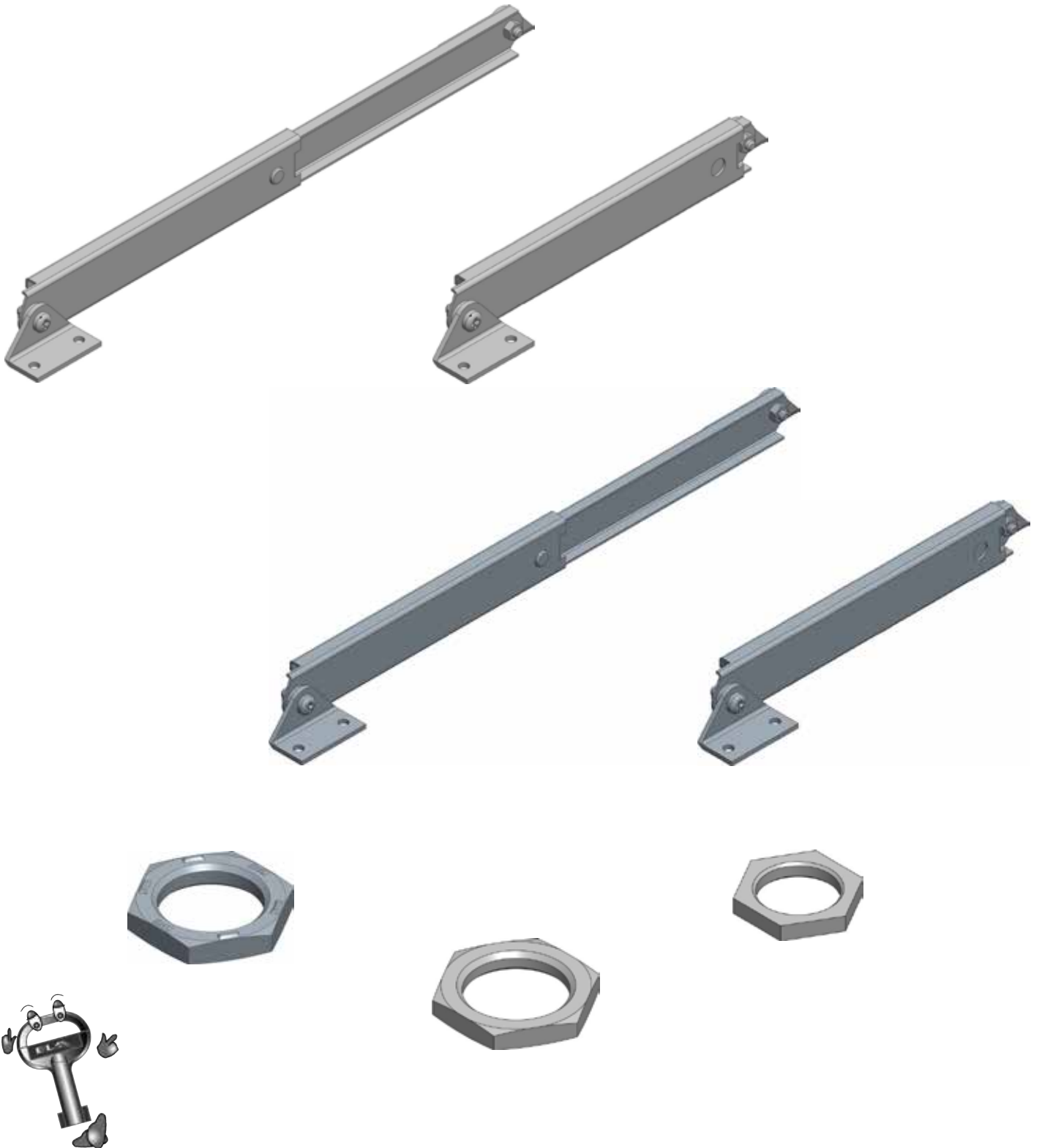

Tartozékok

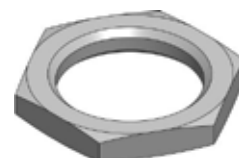
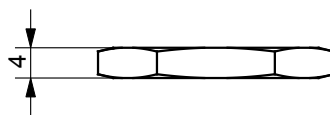
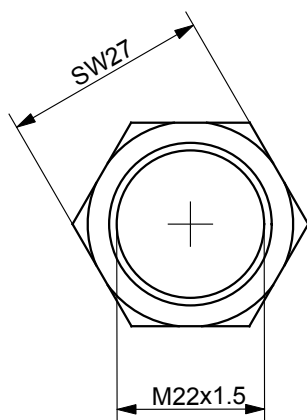

Termékszám	Alapanyag	Felületkezelés
90KO-HT001-00	1.4305	-
90KO-HT002-00	1.4571	-

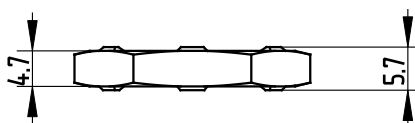
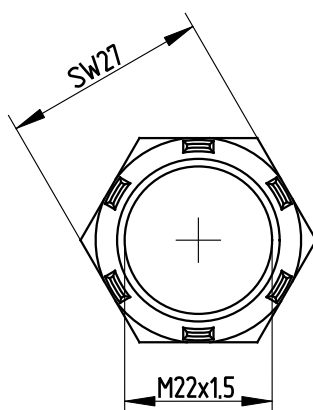

Termékszám	Alapanyag	Felületkezelés
90ZA-HT001-00	cinköntvény	-

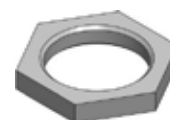
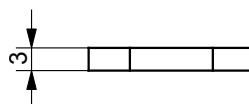
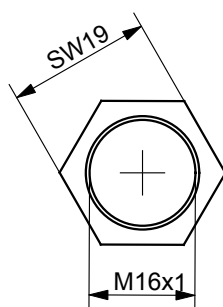

Termékszám	Alapanyag	Felületkezelés
90KO-HT036-00	1.4305	-

Teleszkópos ajtókitámasztók

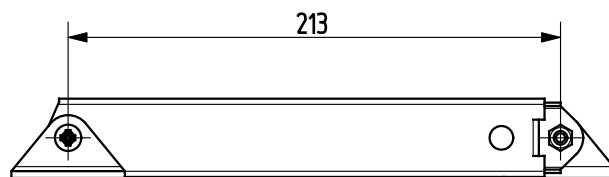
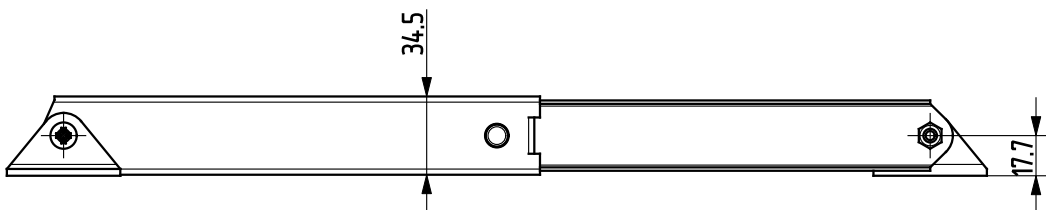
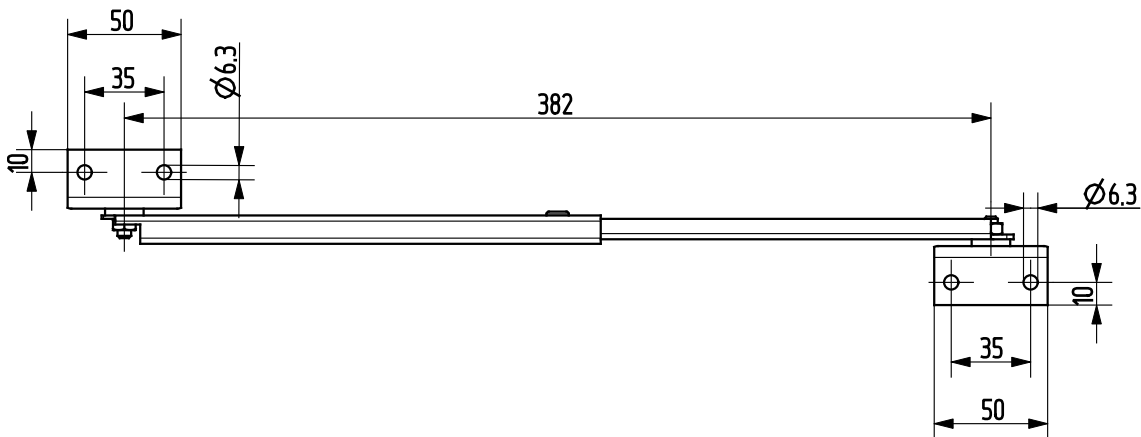
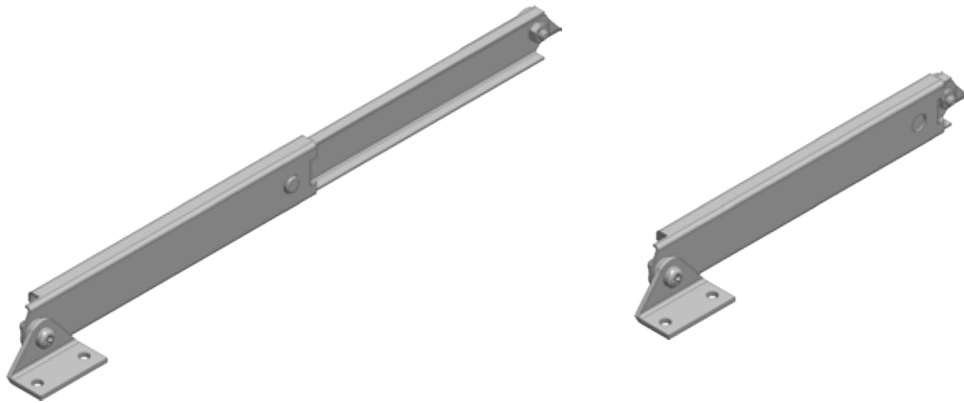

Termékszám	Alapanyag	Felületkezelés
90KO-KIT001-00	1.4301	-

Tartozékok

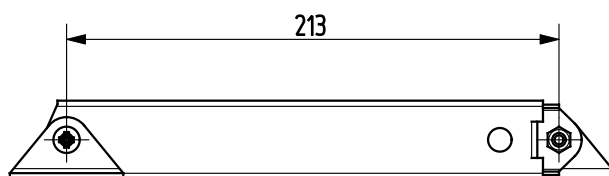
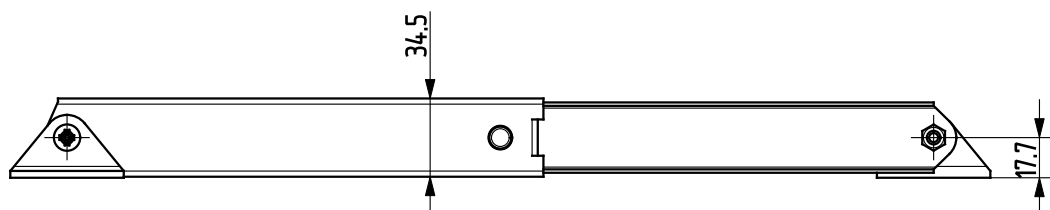
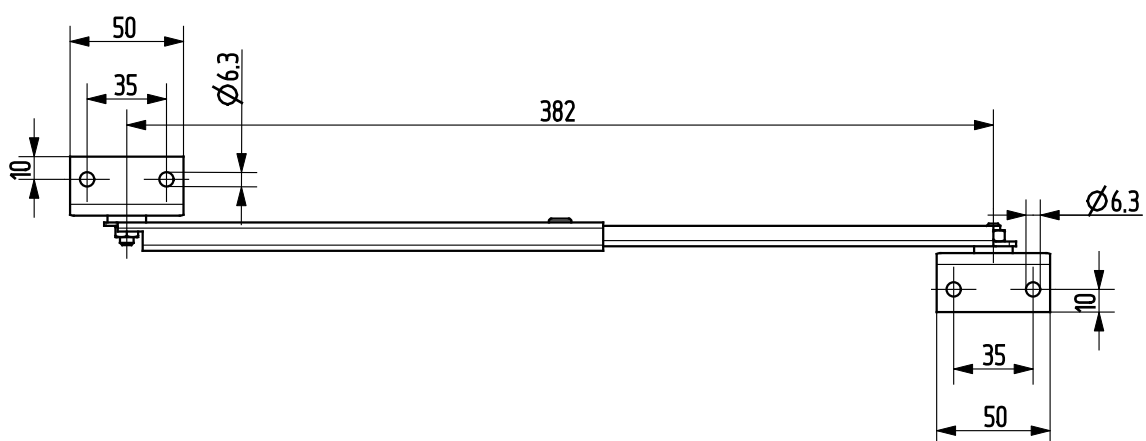
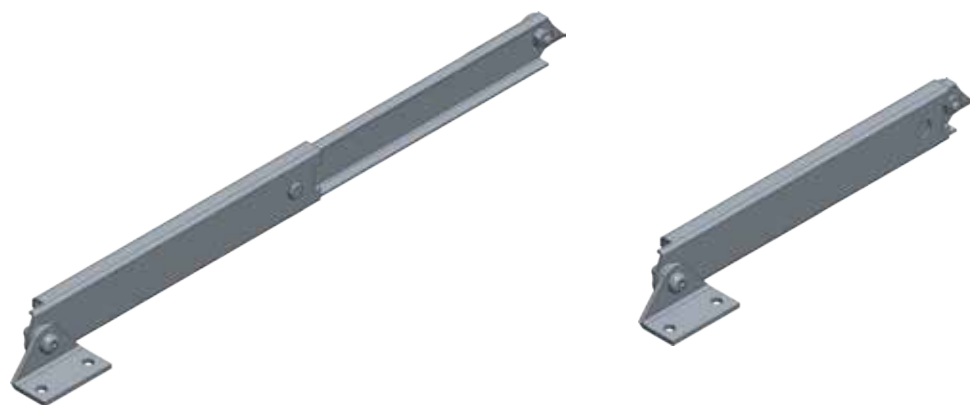

Termékszám	Alapanyag	Felületkezelés
90ST-KIT001-01	ST	horganyozva



TÖMÍTÉSEK



Tömítések

Tömítőprofilok

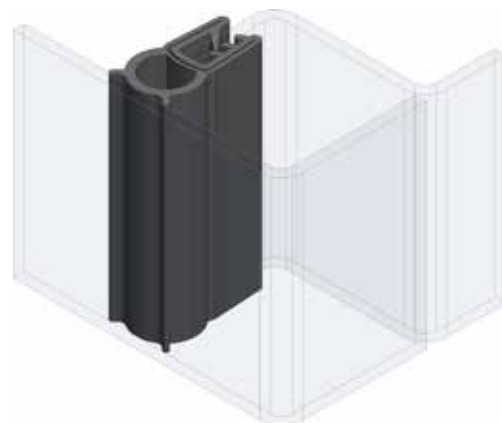
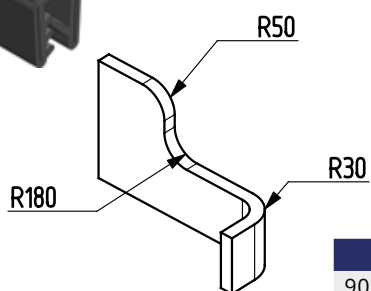

Termékszám	Alapanyag
90GU-E01-00	EPDM

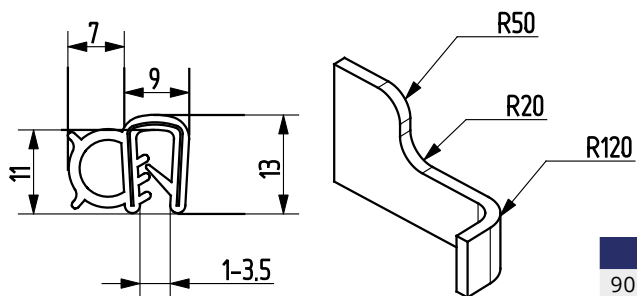

Termékszám	Alapanyag
90GU-E02-00	EPDM

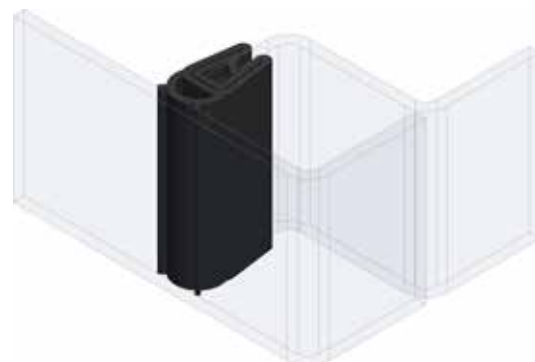
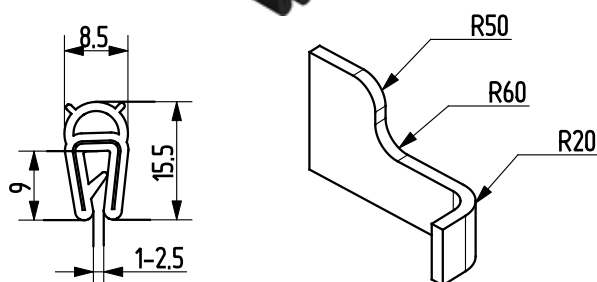

Termékszám	Alapanyag
90GU-E03-00	EPDM

Tömítések

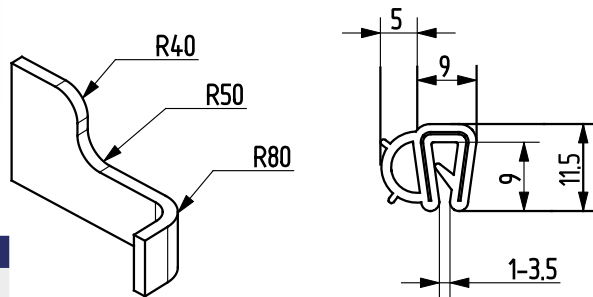

Termékszám 90GU-E04-00 **Alapanyag** EPDM

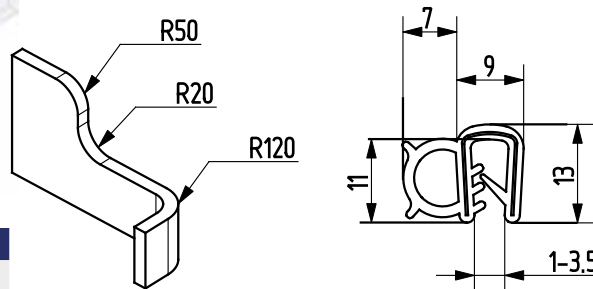
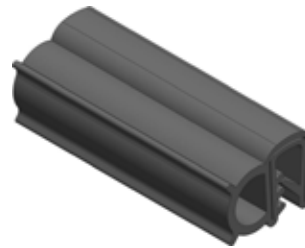

Termékszám 90GU-E05-00 **Alapanyag** NBR

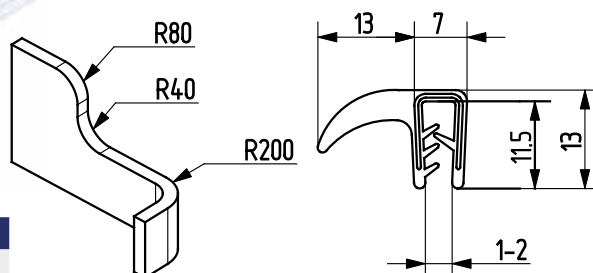
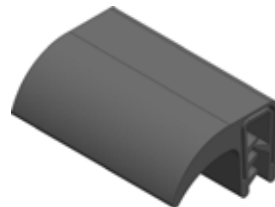

Termékszám 90GU-E06-00 **Alapanyag** EPDM

Tömítések

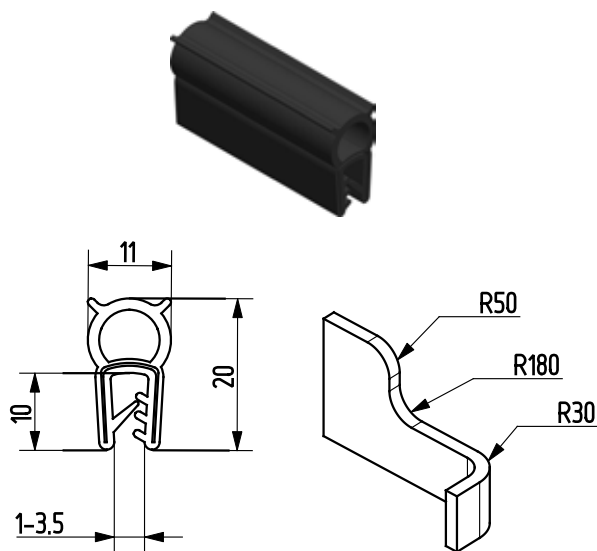

Termékszám	Alapanyag
90GU-E07-00	NBR

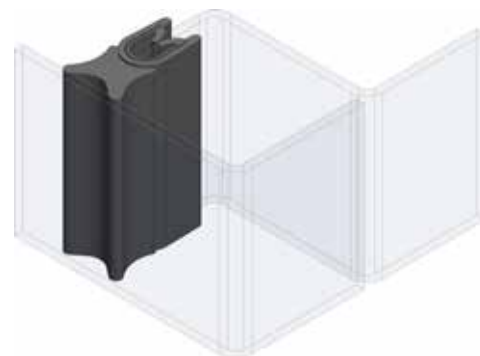
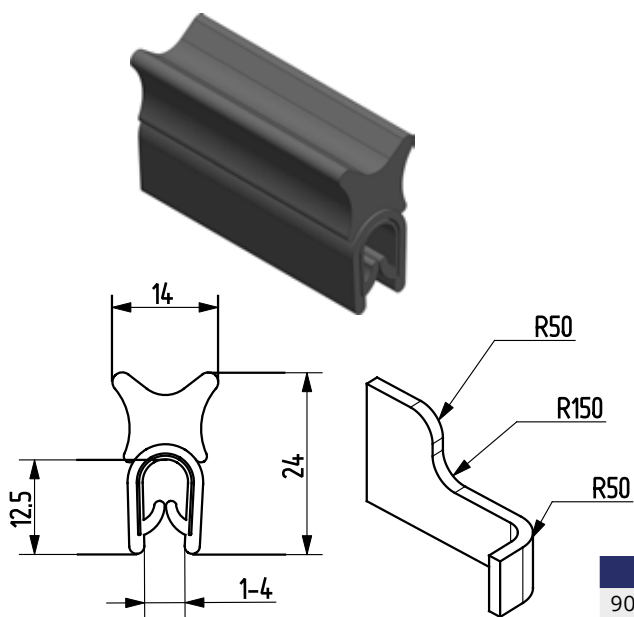

Termékszám	Alapanyag
90GU-E17-00	EPDM/PVC

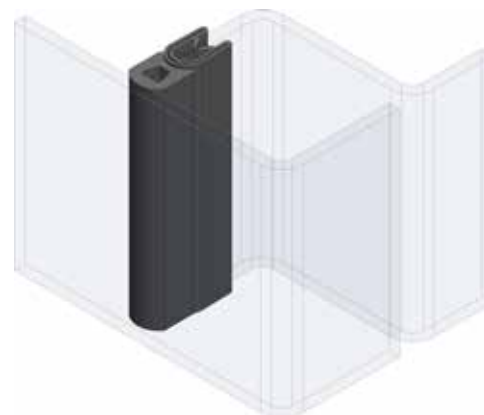
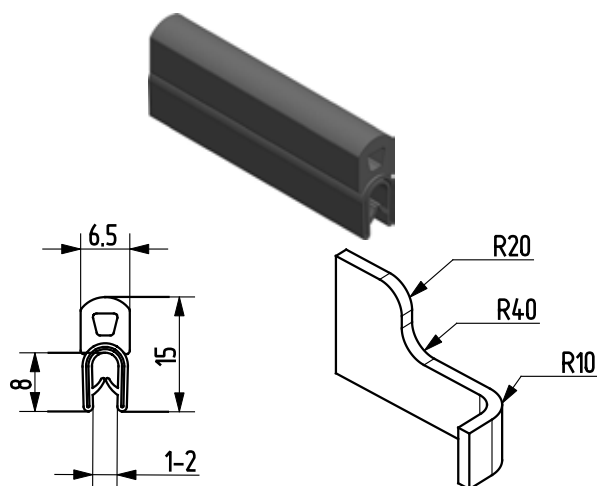

Termékszám	Alapanyag
90GU-E18-00	EPDM

Tömítések

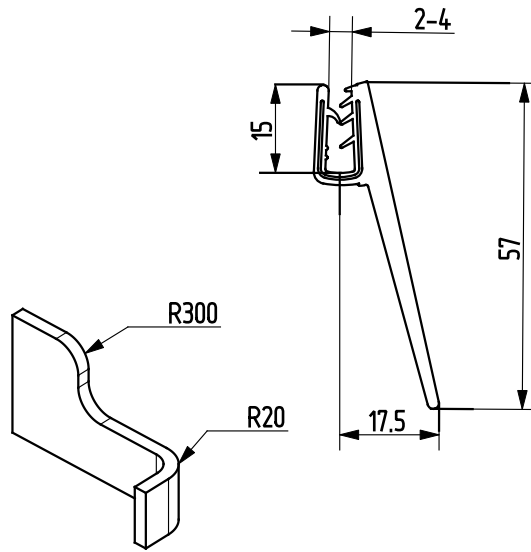

Termékszám 90GU-E19-00 **Alapanyag** EPDM/PVC

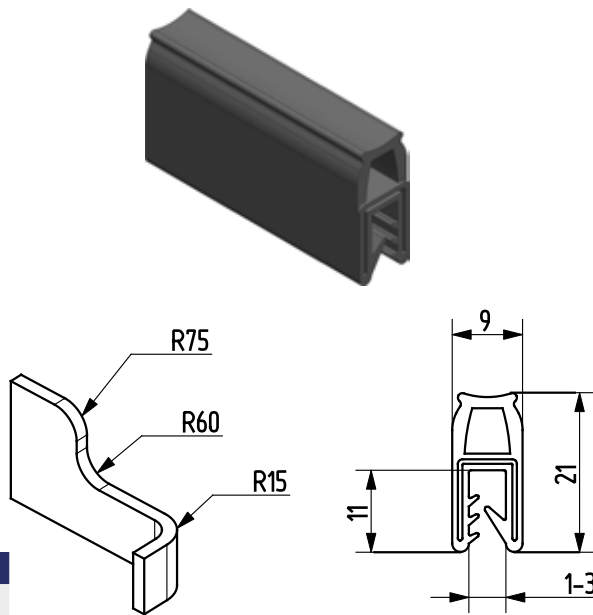
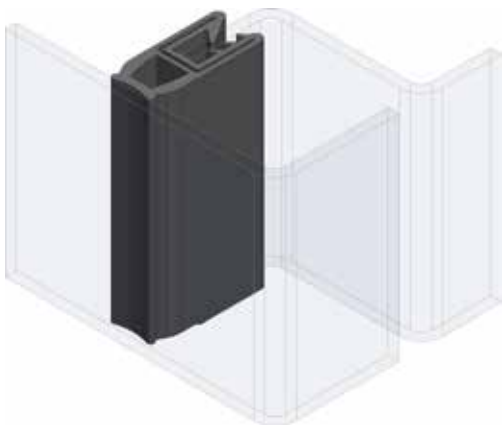

Termékszám 90GU-E20-00 **Alapanyag** EPDM/PVC

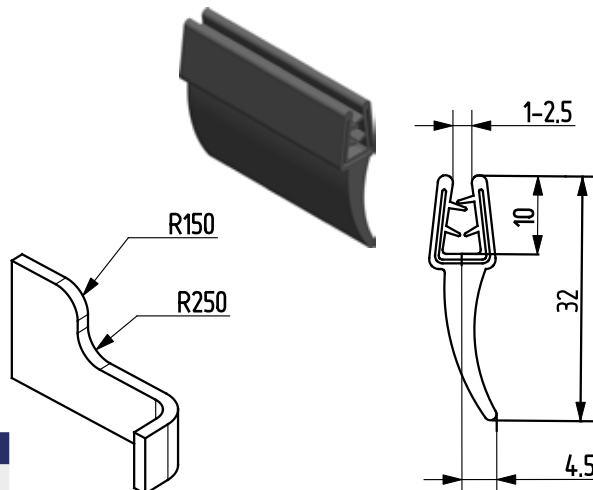

Termékszám 90GU-E21-00 **Alapanyag** EPDM

Tömítések

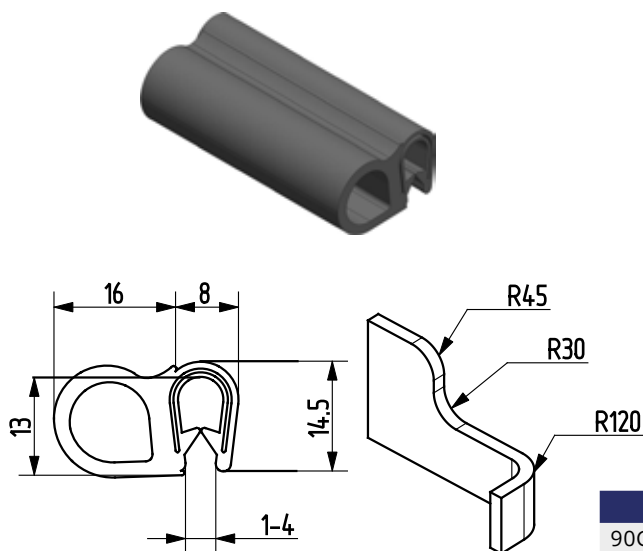

Termékszám	Alapanyag
90GU-E22-00	EPDM/PVC

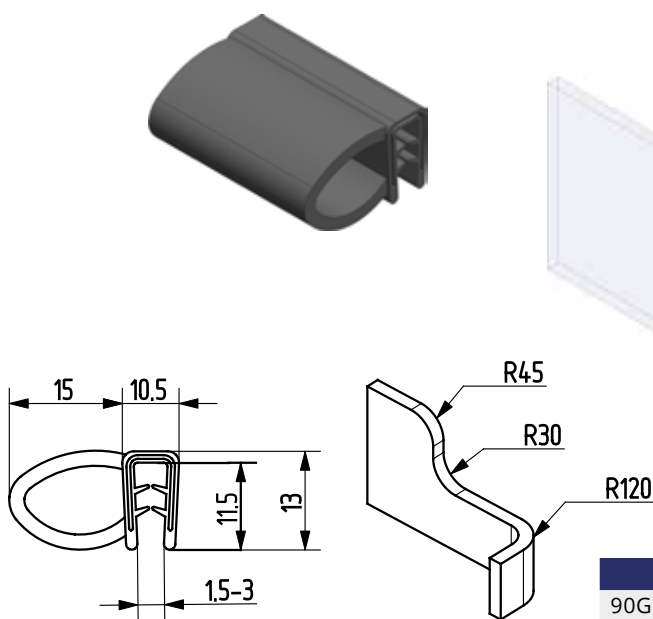

Termékszám	Alapanyag
90GU-E23-00	EPDM/PVC

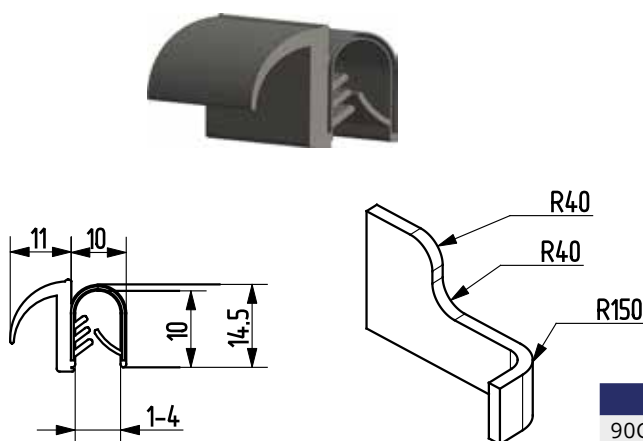

Termékszám	Alapanyag
90GU-E25-00	EPDM/PVC



Befogó profilok

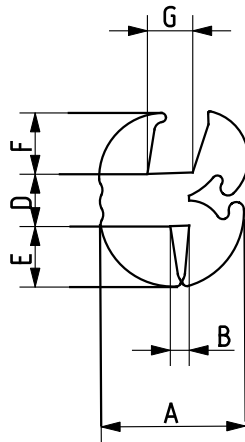
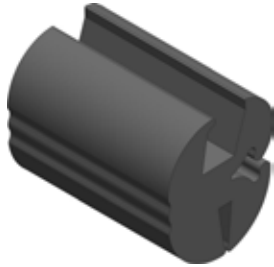

Termékszám	Alapanyag	A	B	C	D	E	F
90GU-E15-00*	EPDM	12.6	3	4	4	5	6
90GU-E14-00**	EPDM	19	2.5	6	7	8	8
90GU-E16-00**	EPDM	16	3	4	7	7	7

Megjegyzés:
 *90GU-E12-00
 töltőprofilal
 **90GU-E13-00
 töltőprofilal

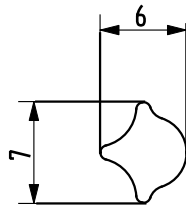
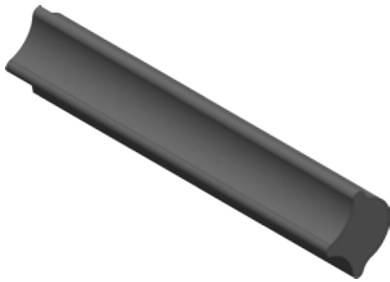

Termékszám	Alapanyag
90GU-E12-00	EPDM

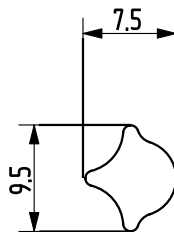
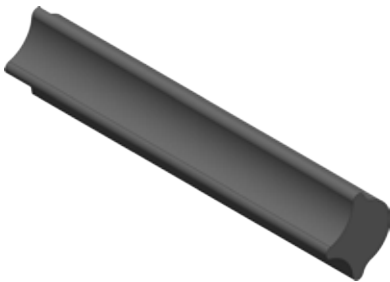

Termékszám	Alapanyag
90GU-E13-00	EPDM

Tömítések

Keretprofilok

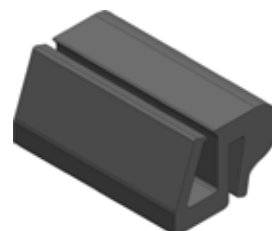
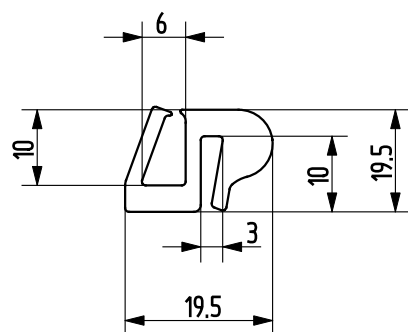

Termékszám	Alapanyag
90GU-E11-00	EPDM

Öntapadós tömítések

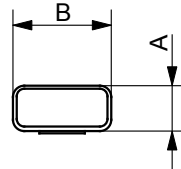

A	B	EPDM	NEOPRENE
2	6	90GU-TE001-00	90GU-TN001-00
2	9	90GU-TE002-00	90GU-TN002-00
2	10	90GU-TE003-00	90GU-TN003-00
2	12	90GU-TE004-00	90GU-TN004-00
2	15	90GU-TE005-00	90GU-TN005-00
2	20	90GU-TE006-00	90GU-TN006-00
2	25	90GU-TE007-00	90GU-TN007-00
2	30	90GU-T008-00	90GU-TN008-00

3	6	90GU-TE009-00	90GU-TN009-00
3	9	90GU-TE010-00	90GU-TN010-00
3	10	90GU-TE011-00	90GU-TN011-00
3	12	90GU-TE012-00	90GU-TN012-00
3	15	90GU-TE013-00	90GU-TN013-00
3	20	90GU-TE014-00	90GU-TN014-00
3	25	90GU-TE015-00	90GU-TN015-00
3	30	90GU-TE016-00	90GU-TN016-00

6	6	90GU-TE033-00	90GU-TN033-00
6	9	90GU-TE034-00	90GU-TN034-00
6	10	90GU-TE035-00	90GU-TN035-00
6	12	90GU-TE036-00	90GU-TN036-00
6	15	90GU-TE037-00	90GU-TN037-00
6	20	90GU-TE038-00	90GU-TN038-00
6	25	90GU-TE039-00	90GU-TN039-00
6	30	90GU-TE040-00	90GU-TN040-00

4	6	90GU-TE017-00	90GU-TN017-00
4	9	90GU-TE018-00	90GU-TN018-00
4	10	90GU-TE019-00	90GU-TN019-00
4	12	90GU-TE020-00	90GU-TN020-00
4	15	90GU-TE021-00	90GU-TN021-00
4	20	90GU-TE022-00	90GU-TN022-00
4	25	90GU-TE023-00	90GU-TN023-00
4	30	90GU-TE024-00	90GU-TN024-00

8	6	90GU-TE041-00	90GU-TN041-00
8	9	90GU-TE042-00	90GU-TN042-00
8	10	90GU-TE043-00	90GU-TN043-00
8	12	90GU-TE044-00	90GU-TN044-00
8	15	90GU-TE045-00	90GU-TN045-00
8	20	90GU-TE046-00	90GU-TN046-00
8	25	90GU-TE047-00	90GU-TN047-00
8	30	90GU-TE048-00	90GU-TN048-00

5	6	90GU-TE025-00	90GU-TN025-00
5	9	90GU-TE026-00	90GU-TN026-00
5	10	90GU-TE027-00	90GU-TN027-00
5	12	90GU-TE028-00	90GU-TN028-00
5	15	90GU-TE029-00	90GU-TN029-00
5	20	90GU-TE030-00	90GU-TN030-00
5	25	90GU-TE031-00	90GU-TN031-00
5	30	90GU-TE032-00	90GU-TN032-00

10	6	90GU-TE049-00	90GU-TN049-00
10	9	90GU-TE050-00	90GU-TN050-00
10	10	90GU-TE051-00	90GU-TN051-00
10	12	90GU-TE052-00	90GU-TN052-00
10	15	90GU-TE053-00	90GU-TN053-00
10	20	90GU-TE054-00	90GU-TN054-00
10	25	90GU-TE055-00	90GU-TN055-00
10	30	90GU-TE056-00	90GU-TN056-00

Tömítések

Élvédő profilok

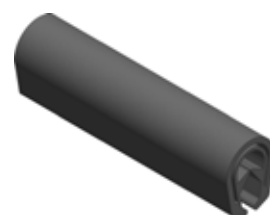
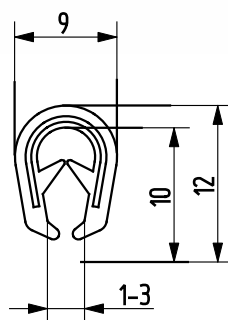
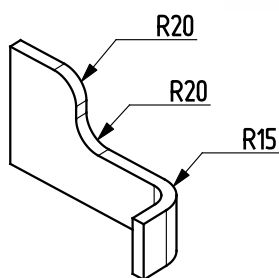

Termékszám

90GU-E24-00

Alapanyag

PVC

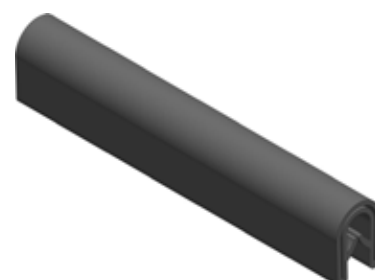
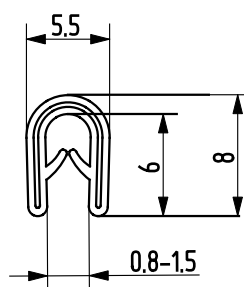
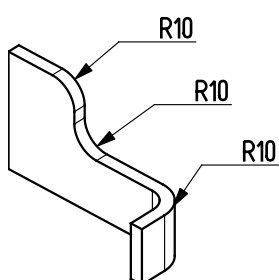

Termékszám

90GU-E08-00

Alapanyag

PVC

Tömítések

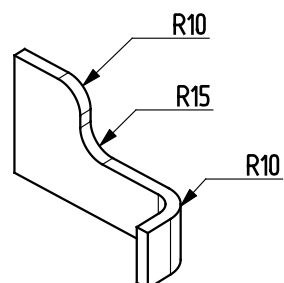
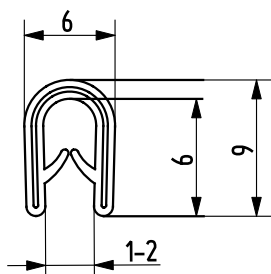
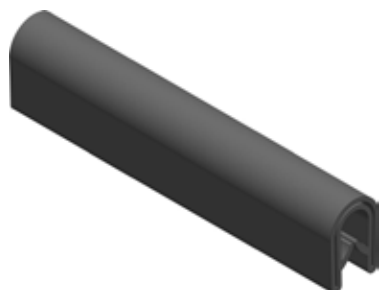

Termékszám	Alapanyag
90GU-E09-00	PVC

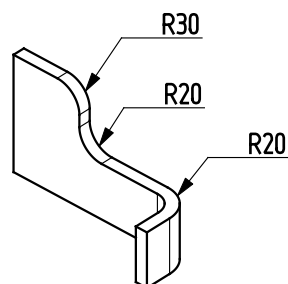
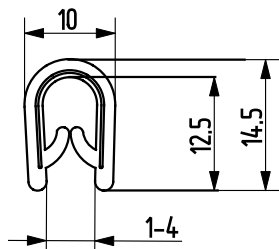
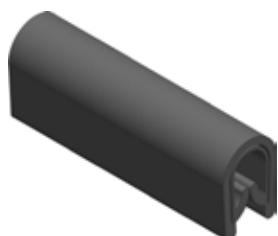

Termékszám	Alapanyag
90GU-E10-00	PVC



KULCSOK



Kulcsok

Megjegyzés:
*vevői logóval
rendelhető

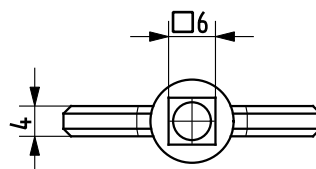
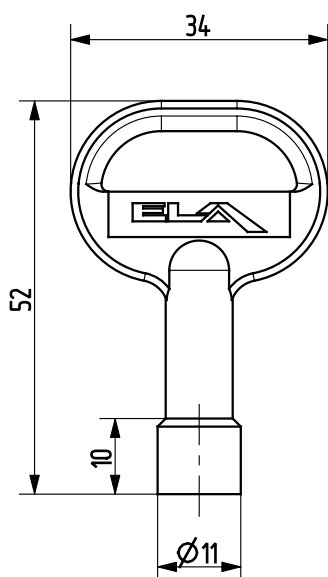

Termékszám	Alapanyag	Felületkezelés
90ZA-ZK001-06*	cinköntvény	fekete porszórt

Megjegyzés:
*vevői logóval
rendelhető

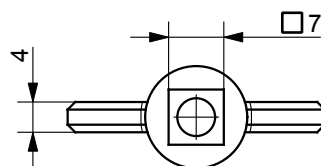
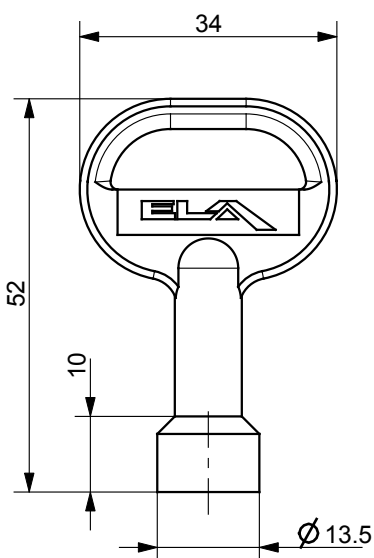

Termékszám	Alapanyag	Felületkezelés	Típus
90ZA-ZK002-06*	cinköntvény	fekete porszórt	□ 7 mm
90ZA-ZK003-06*	cinköntvény	fekete porszórt	□ 8 mm
90ZA-ZK004-06*	cinköntvény	fekete porszórt	△ 7 mm
90ZA-ZK005-06*	cinköntvény	fekete porszórt	△ 6.5 mm
90ZA-ZK006-06*	cinköntvény	fekete porszórt	△ 8 mm

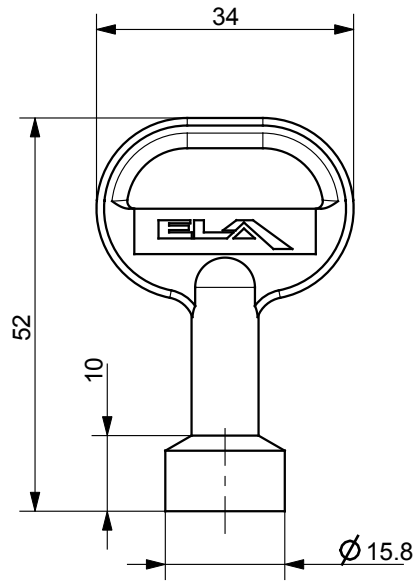
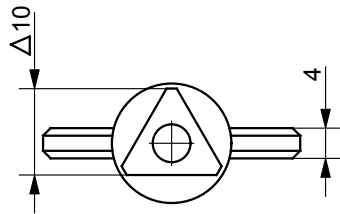

Megjegyzés:
*vevői logóval
rendelhető



Termékszám	Alapanyag	Felületkezelés
90ZA-ZK007-06*	cinköntvény	fekete porszórt

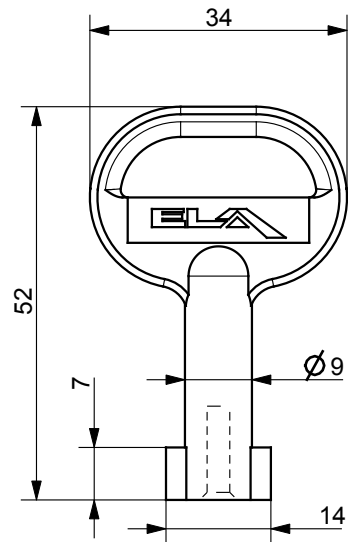
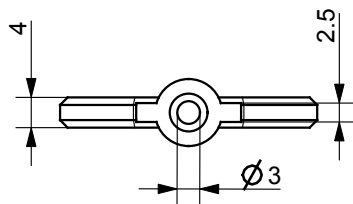

Megjegyzés:
*vevői logóval
rendelhető



Termékszám	Alapanyag	Felületkezelés	Típus
90ZA-ZK008-06*	cinköntvény	fekete porszórt	3 mm duplatoll
90ZA-ZK009-06*	cinköntvény	cinköntvény	5 mm duplatoll

Kulcsok

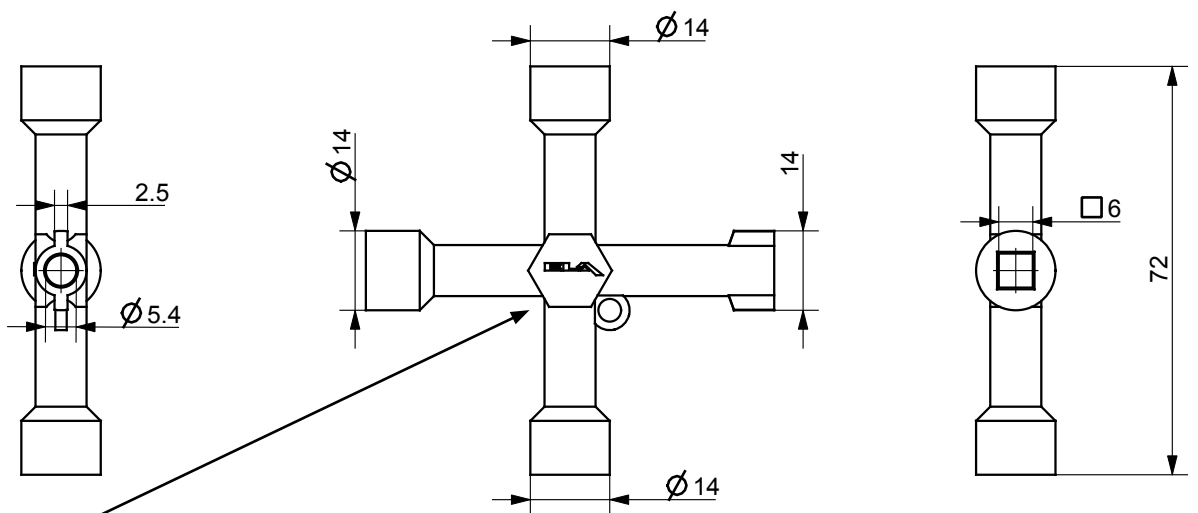
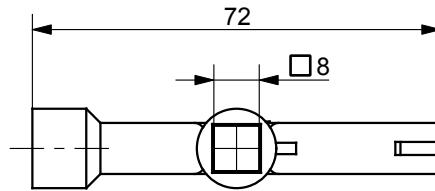

Megjegyzés:
*vevői logóval
rendelhető

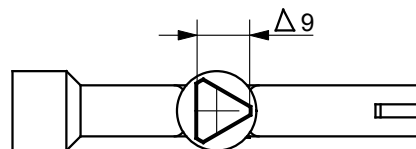

Termékszám	Alapanyag	Felületkezelés
90ZA-ZK010-06*	cinköntvény	fekete porszórt

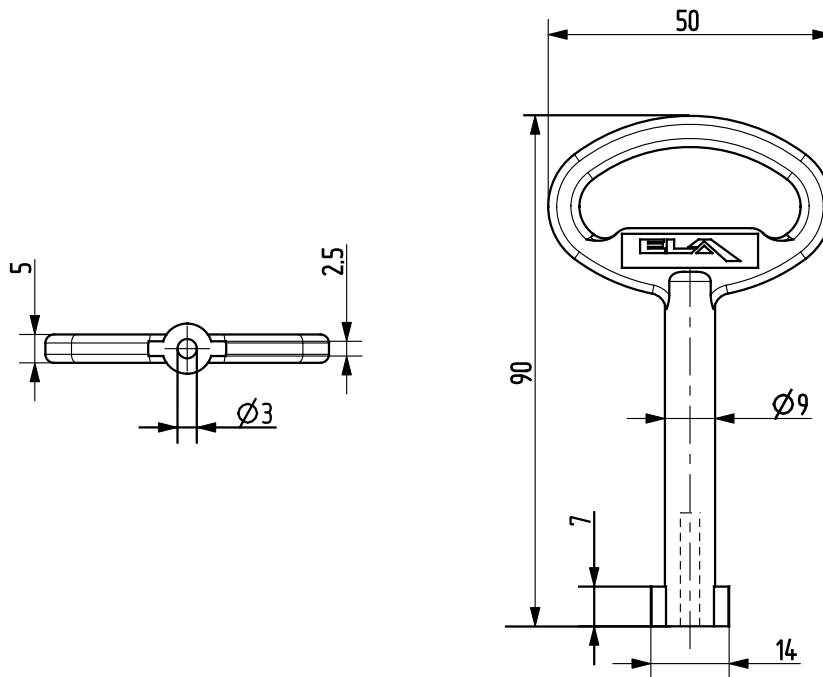

Megjegyzés:
*vevői logóval
rendelhető



Termékszám	Alapanyag	Felületkezelés	Típus
90ZA-ZK011-06*	cinköntvény	fekete porszórt	3 mm duplatoll
90ZA-ZK012-06*	cinköntvény	fekete porszórt	5 mm duplatoll

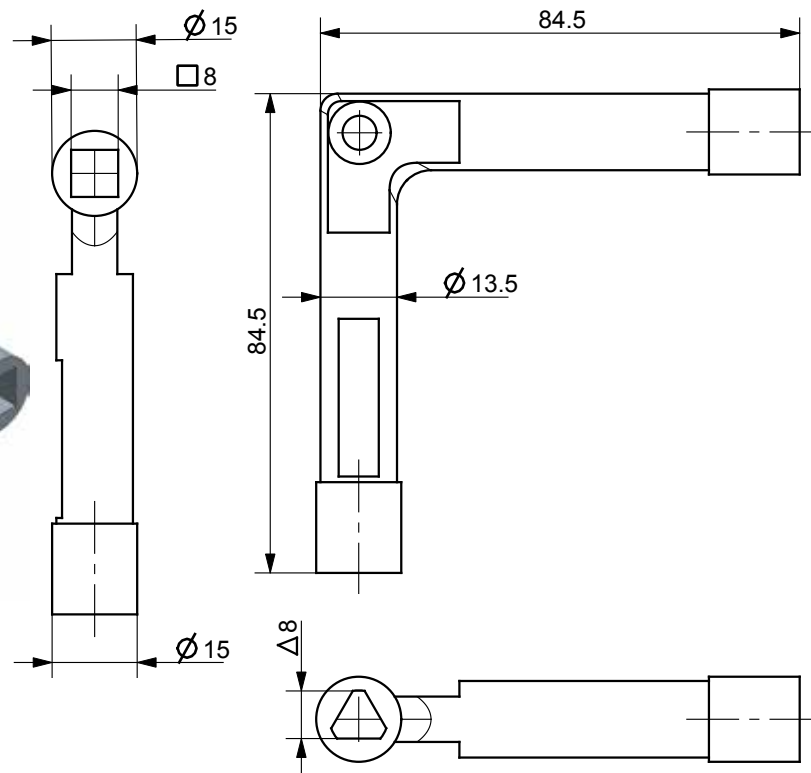

Termékszám	Alapanyag	Felületkezelés
90ZA-ZK019-04	cinköntvény	krómozva

